

# **DINGS'** ENGINEERING AND MANUFACTURING MOTION CONTROL MOTOR PRODUCTS

[www.dingsmotion.com](http://www.dingsmotion.com)

DINGS' ENGINEERING AND MANUFACTURING MOTION CONTROL MOTOR PRODUCTS

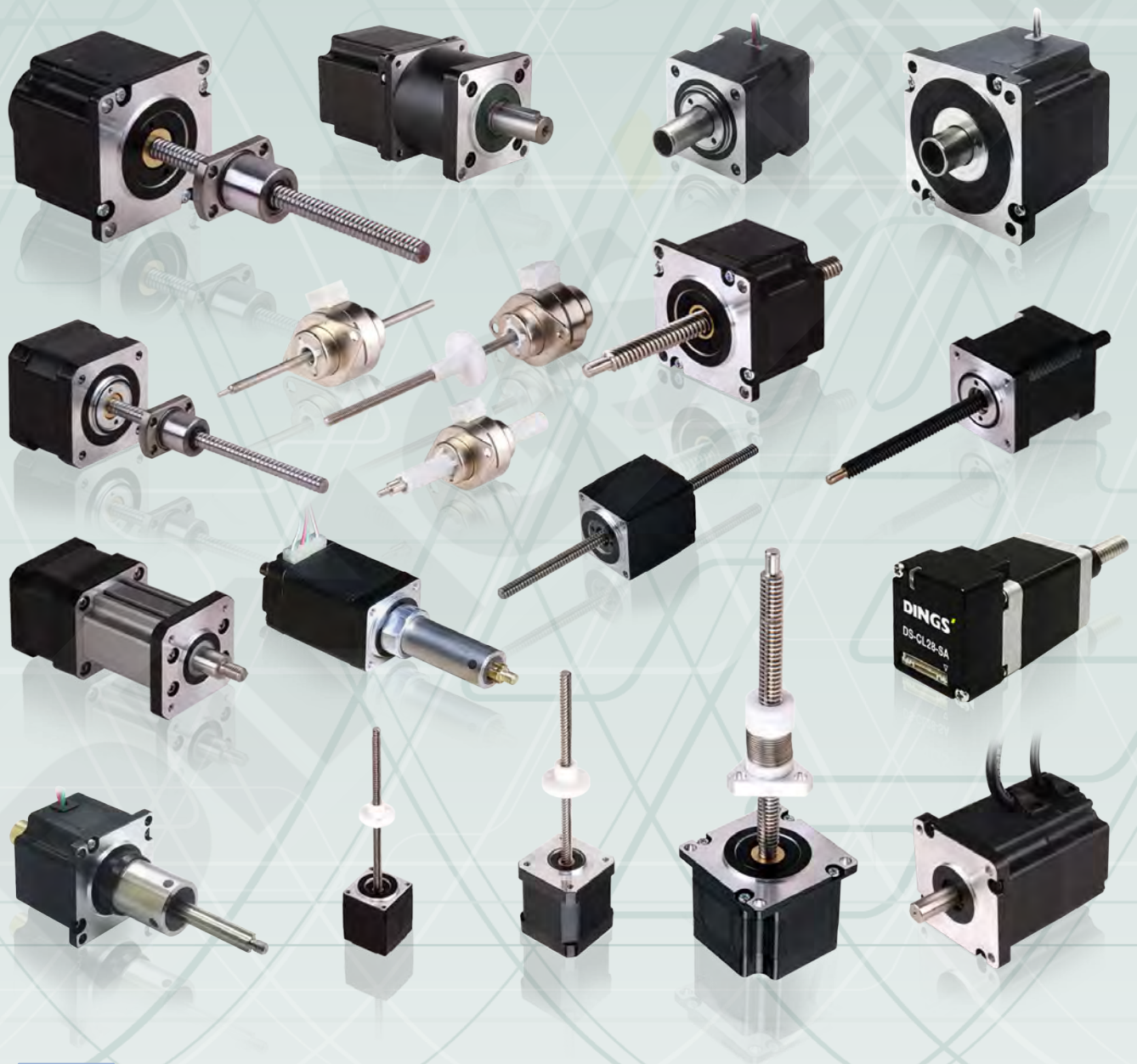

**2018**  
**2019**

ver.1.4

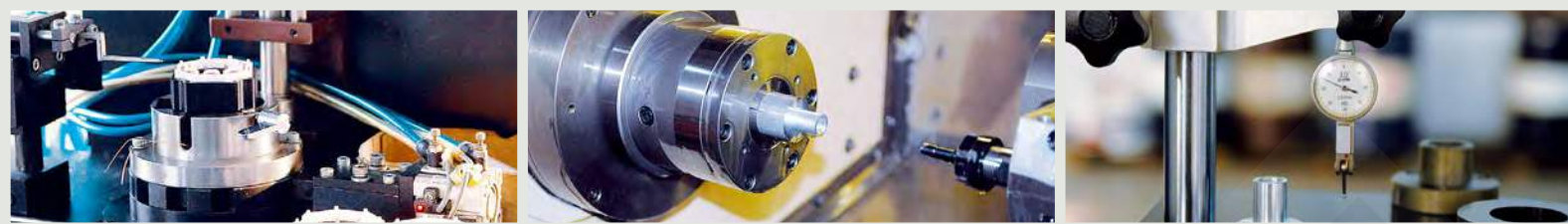

## Welcome to DINGS'

Combining more than 50 years of experience in the precise motor products for motion control industry, with manufacturing facility located in China and the United States, and service and supporting centers worldwide, DINGS' provides a supply chain that allows us to deliver quality, cost effective product solutions to our OEM customers in Asia, North America and Europe. Our ability to create innovative custom solutions allows us the flexibility to meet your diverse custom applications.

We now offer a broad range of precision linear motion products, hybrid stepping motors, Brush and brushless DC motors. All our products offer high performance in demanding applications such as laboratory automation, medical instrumentation, semiconductor fabrication and industrial applications.

For more information on our products and the latest news, please visit our website:

[www.dingsmotion.com](http://www.dingsmotion.com)

Or contact DINGS' technical supports and your local DINGS' representatives.





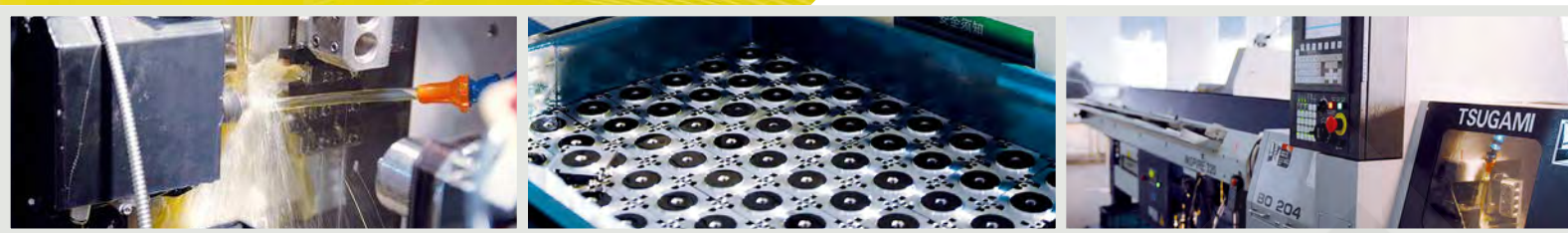

## WARRANTY

### Twenty Four Month Limited Warranty

Seller warrants its products delivered hereunder to conform to stated specifications and to be free from defects in materials and workmanship. This warranty shall not apply to any product which shall have been improperly installed or subjected to misuse or neglect or which has been repaired or altered except by seller's accredited representative, nor to any product which has been subjected to accident.

## DISCLAIMER

The information in this catalog has been carefully checked and is believed to be accurate; however, no responsibility is assumed for inaccuracies.

DINGS' reserves the right to make changes without further notice to any products herein to improve reliability, function, or design.

DINGS' does not recommend the use of its products in life support or aircraft applications wherein a failure or malfunction of the product may directly threaten life or injury.



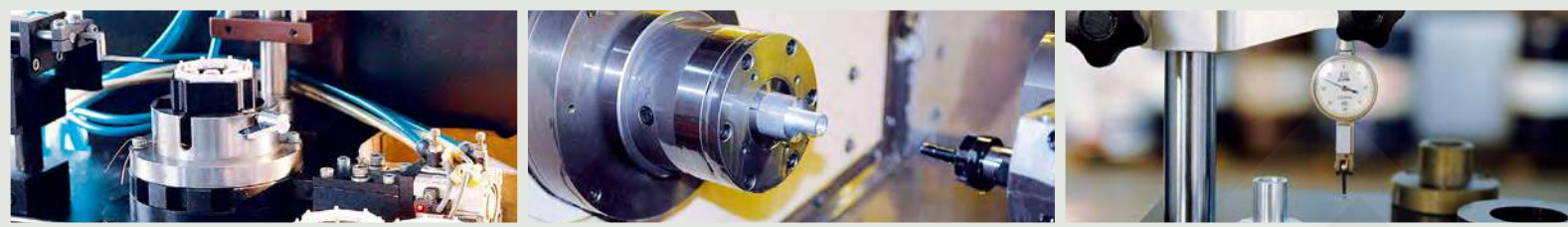

## General Catalog

### A Stepper motor linear actuator

A-0

#### Hybrid stepper motor lead screw linear actuators

A-1



#### Hybrid stepper motor ball screw linear actuators

A-54



#### PM stepper linear actuators

A-77





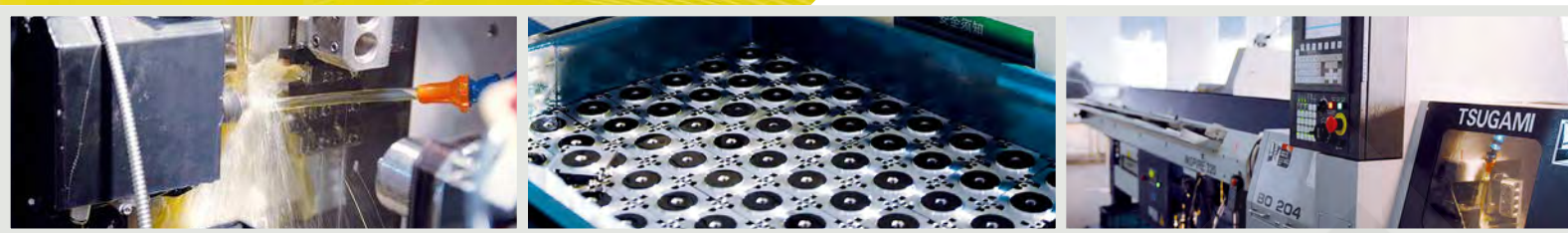

## B Hybrid rotary stepper motor

B-1

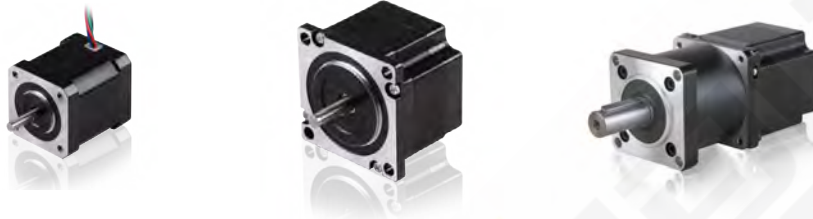

## C Hollow shaft hybrid stepper motor

C-1



## D Brushless DC motor

D-1



## E Stepper motor driver

E-1



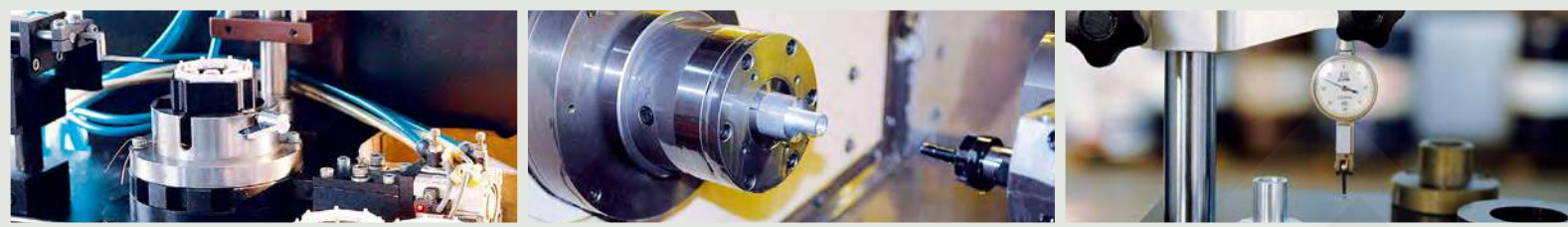

## TABLE OF CONTENTS

### **A** Stepper motor linear actuator

#### Hybrid stepper motor lead screw linear actuators

Part number construction	A-2
Lead screw code schedule	A-3
Product selection guide	A-4
Techlogy overview	A-5
General specifications	A-11
Size 8 · 20 mm series	A-12
Size 11 · 28 mm series	A-16
Size 14 · 35 mm series	A-20
Size 17 · 42 mm series	A-26
Size 23 · 57 mm series	A-32
Size 34 · 86 mm series	A-38
Accessories and options	A-41
Installation guide	A-52

#### Hybrid stepper motor ball screw linear actuators

Part number construction	A-55
Ball screw lead code schedule	A-56
Size 8 · 20 mm series	A-57
Size 11 · 28 mm series	A-60
Size 14 · 35 mm series	A-63
Size 17 · 42 mm series	A-66
Size 23 · 57 mm series	A-69
Accessories and options	A-72
Installation guide	A-75

#### PM stepper linear actuators

Part number construction	A-78
Product overview	A-79
20 mm series	A-80
25 mm series	A-84
36 mm series	A-88





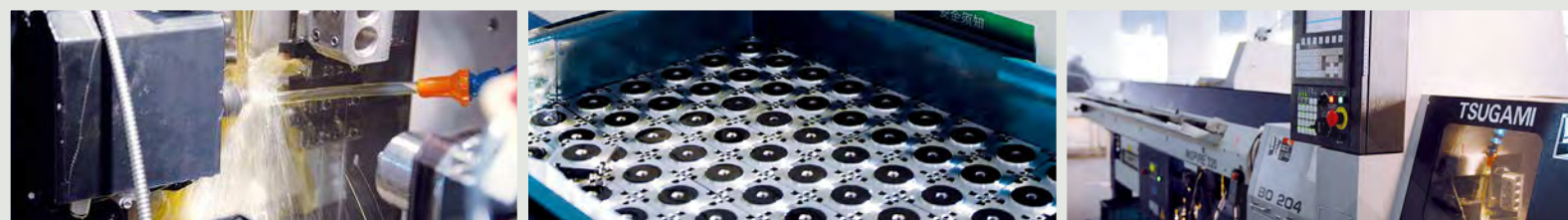

## B Hybrid rotary stepper motor

Part number construction	B-2
Product overview	B-3
Size 8 · 20 mm series	B-4
Size 11 · 28mm series	B-6
Size 14 · 35 mm series	B-8
Size 17 · 42 mm series	B-10
Size 23 · 57 mm series	B-12
Size 24 · 60 mm series	B-14
Size 34 · 86 mm series	B-16
Accessories and options	B-18

## C Hollow shaft hybrid stepper

Part number construction	C-2
Product overview	C-3
Size 8 · 20 mm series	C-4
Size 11 · 28mm series	C-6
Size 14 · 35 mm series	C-8
Size 17 · 42 mm series	C-10
Size 23 · 57 mm series	C-12
Size 34 · 86 mm series	C-14

## D Brushless DC motor

Part number construction	D-2
Size 17 · 42 mm series	D-3
Size 23 · 57 mm series	D-4
Size 24 · 60 mm series	D-5
Size 28 · 70 mm series	D-6
Size 32 · 80 mm series	D-7
Size 34 · 86 mm series	D-8
Size 40 · 100 mm series	D-9
Size 43 · 110 mm series	D-10

## E Stepper motor driver

DS-2422-001	E-2
DS-5045-003	E-3
DS-2MSD8078-2	E-4
DS-OL17/23-I series	E-5
ST-484 close loop driver	E-11
Vector series integrated systems	E-13
DS-CL28-SA Integrated closed-loop drive	E-18



# A Stepper motor linear actuator

DINGS' offers a unique line of stepper motor linear actuators that open new avenues for equipment designers who require high performance and exceptional endurance in a very small package. The various products convert the rotation movement to linear motion directly on motor, with engineering thermoplastics nut and a stainless steel acme lead screw. This allows the linear actuator to provide quiet, efficient, durable and cost effective linear motion solutions.

These linear actuators are ideal for applications requiring a combination of precise positioning, rapid motion and long life. Typical applications include X-Y tables, medical equipment, semiconductor handling, telecommunications equipment, valve control, and numerous other uses.

Variety of customization upon to request, such as different screw length, special design nut, anti-backlash nut, safety brake, encoder.

For higher efficiency and extreme long life and high precision applications, DINGS' provides the linear actuator with different grade of ball screw at reasonable cost.

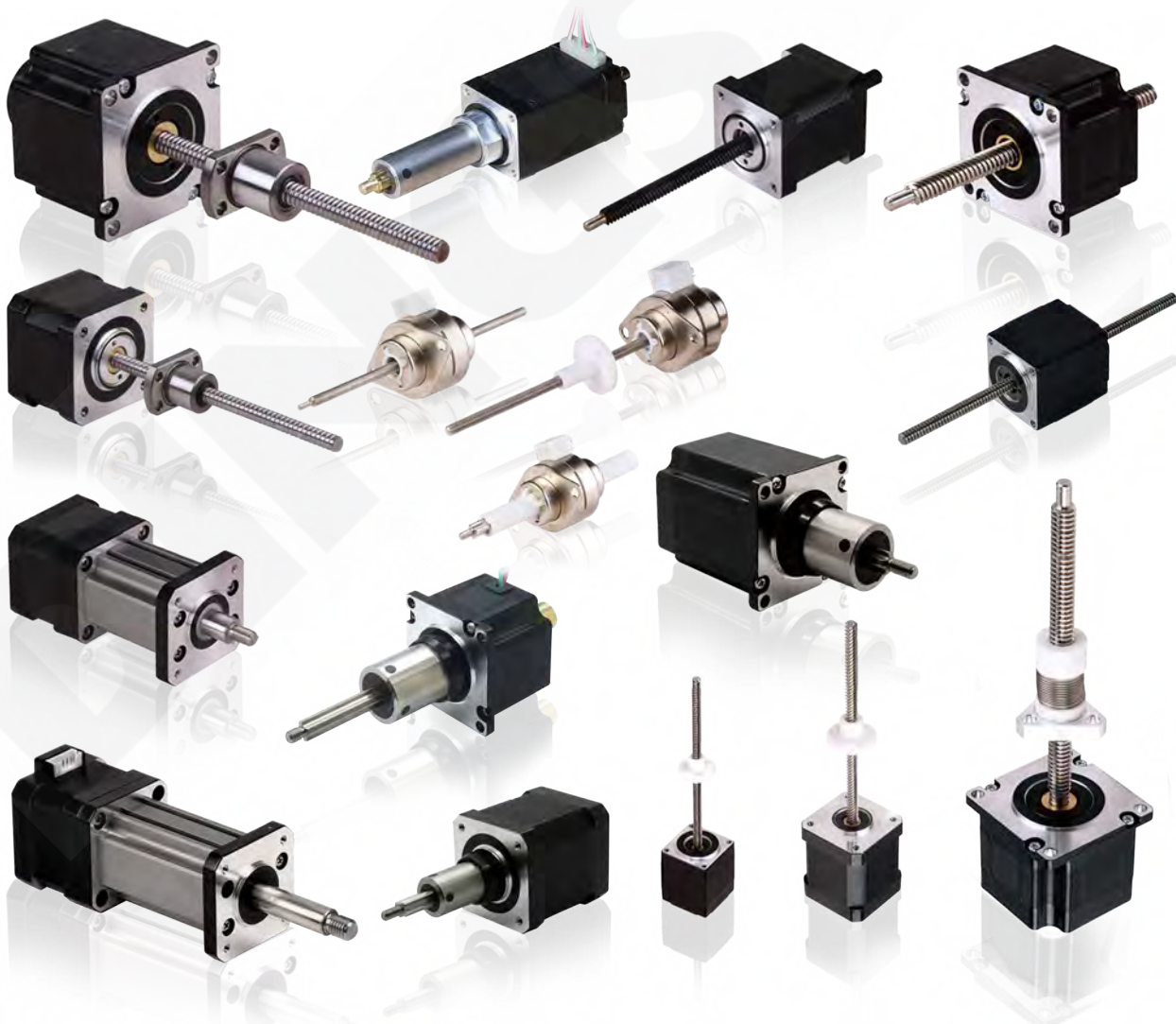



# Hybrid stepper motor lead screw linear actuators

The DINGS' brand of hybrid linear actuators come in six sizes, from 21 mm square to 87 mm square corresponding to size 8, size 11, size 14, size 17, size 23, and size 34. Each size has three designs available – captive, non-captive and an external linear version. There are over twenty different travels per step available, from .00006 inch (.001524 mm) to .005 inch (.127 mm). Micro stepping can be used for even finer resolution.

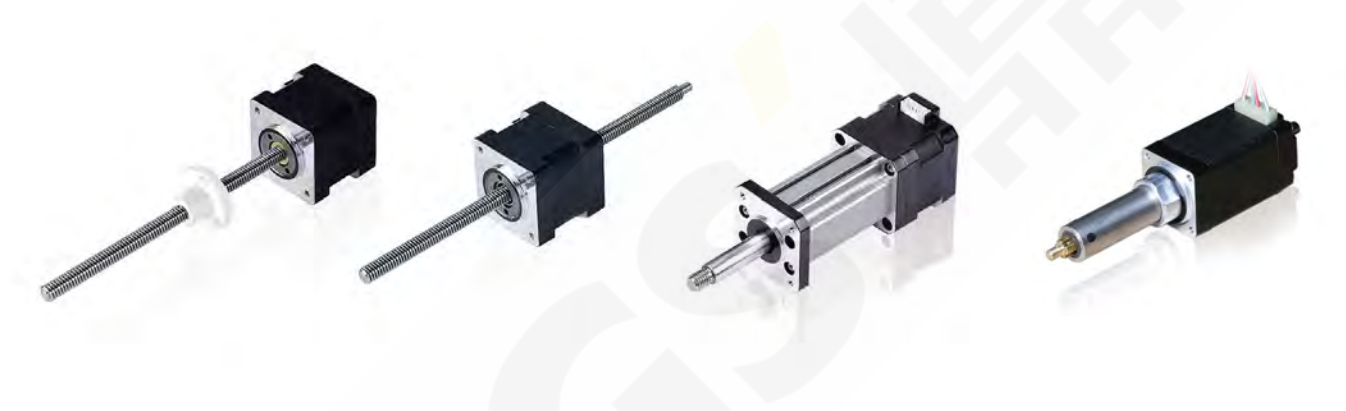

Part number construction	A-2
Lead screw code schedule	A-3
Product selection guide	A-4
Techlogy overview	A-5
General specifications	A-11
Size 8 · 20mm series	A-12
Size 11 · 28mm series	A-16
Size 14 · 35mm series	A-20
Size 17 · 42mm series	A-26
Size 23 · 57mm series	A-32
Size 34 · 86mm series	A-38
Accessories and options	A-41
Installation guide	A-52

## Part Number Construction

BACK TO

17 N 2 1 15 K 4 - 101.6 T M S EK2 - 001

① ② ③ ④ ⑤ ⑥ ⑦ ⑧ ⑨ ⑩ ⑪ ⑫ ⑬

① Motor Size

CODE	8	11	14	17	23	34
MOTOR SIZE (mm)	20	28	35	42	57	86

② Linear Actuator Type

E = External Linear  
 N = Non-captive linear  
 C = Captive linear  
 K = Kaptive linear

③ Step Angle

2 = 2 Phase with 1.8°  
 4 = 2 Phase with 0.9°  
 3 = 3 Phase with 1.2°  
 5 = 5 Phase with 0.72°

④ Motor Length / Stack

1 = Single Stack  
 2 = Double Stack

⑤ Rated Current/Phase

XX = X.X (A)/Phase

⑥ Lead Screw Code

⑦ Number of Lead Wires

4 = Qty 4 Flying Leads  
 6 = Qty 6 Flying Leads  
 8 = Qty 8 Flying Leads

⑧ Lead Screw Length / Stroke

XXX = XXX mm Lead screw length  
 (For External Linear/Non-Captive Linear)

XXX = X.XX inch Stroke  
 (For Captive Linear)

⑨ Lead Screw Surface Treatment

T = Teflon Coating  
 S = Standard (No Teflon Coating)

⑩ End Machining

M = Metric  
 U = UNC  
 S = Smooth  
 C = Customize  
 N = None

⑪ Nut Style

S = Standard Flange Nut  
 A = Anti-Backlash Nut  
 C = Customized Nut

⑫ Encoder Option

EKX = Encoder (XX = Encoder Code)  
 B = Brake  
 X = Rear Shaft  
 R = Encoder Ready (Hole and Shaft)  
 C = Customize  
 N = None  
 R20 = RMB20SC10BC10 for size8  
 R28 = RMB28SC10BC10 for size11

⑬ Customer Sequence Number

### EXAMPLE

Part Number	17N2115K4-101.6TMSEK2
Description	Nema 17 Non-captive Linear Actuator 2 Phase with 1.8 Degree Step Angle Single Stack 1.5A / Phase "K" Lead (0.1"/2.54mm) 4 Flying Leads Screw Length: 101.6mm Teflon Coated Screw Metric End Machining Standard Nut EK2 Encoder with Single Output, 192 lines



## Lead Screw Code Schedule

BACK TO

Lead Code	1.8 Degree Motor Travel per Step mm(inch)	Motor Size (mm)						
		20	28	35	42	57	86	
		Screw Dia. mm(inch)						
		Φ3.5 (0.138")	Φ4.77 (0.188")	Φ5.56 (0.218")	Φ6.35 (0.25")	Φ8 (0.315")	Φ9.525 (0.375")	Φ10 (0.394")
AL	0.00063" (0.001588)		0.0125" (0.3175)					
AA	0.00012" (0.003048)	0.024" (0.6096)			0.024" (0.6096)			
A	0.000125" (0.003175)		0.025" (0.635)				0.025" (0.635)	
B	0.00024" (0.006096)	0.048" (1.2192)			0.048" (1.2192)			
D	0.00025" (0.00635)		0.05" (1.27)		0.05" (1.27)		1.27 (0.05")	
F	0.0003125" (0.0079375)				0.0625" (1.5875)		0.0625" (1.5875)	
H	0.000417" (0.010583)					0.083" (2.1167)	0.083" (2.1167)	
J	0.00048" (0.012192)			0.096" (2.4384)	0.096" (2.4384)			
K	0.0005" (0.0127)		0.1" (2.54)		0.1" (2.54)		0.1" (2.54)	0.1" (2.54)
L	0.000625" (0.015875)				0.125" (3.175)		0.125" (3.175)	0.125" (3.175)
P	0.000833" (0.021167)						0.167" (4.2333)	
Q	0.00096" (0.024384)			0.192" (4.8768)	0.192" (4.8768)			
R	0.001" (0.0254)		0.2" (5.08)				0.2" (5.0800)	0.2" (5.08)
S	0.00125" (0.03175)				0.25" (6.35)		0.25" (6.35)	0.25" (6.35)
U	0.001665" (0.042291)				0.333" (8.4582)			
UA	0.0016667" (0.042333)				0.3333" (8.4667)			
V	0.001875" (0.047625)						0.375" (9.525)	
W	0.00192" (0.048768)				0.384" (9.7536)		0.384" (9.7536)	
X	0.002" (0.0508)		0.4" (10.16)				0.4" (10.16)	
Y	0.0025" (0.0635)				0.5" (12.7)		0.5" (12.7)	0.5" (12.7)
Z	0.005" (0.127)						1" (25.4)	1" (25.4)
AF	0.00015 (0.000059")	0.3 (0.0118")						
AB	0.005 (0.000197")	1.0 (0.0394")			1.0 (0.0394")			
G	0.01 (0.000394")	2.0 (0.0787")				2.0000 (0.0787")	2.0 (0.0787")	
M	0.02 (0.000787")	4.0 (0.1575")				4.0 (0.1575")		
T	0.04 (0.001575")	8.0 (0.3150")				8.0 (0.3150")		

\* Remark: 8mm diameter of lead screw of 35, 42 and 57mm is not applicable for Non-Captive and Anti-Backlash Nut \*

## Product Selection Guide

[BACK TO](#)

To reduce complexity and cost of a design, it is important to accurately size a motor/lead screw combination. Below are a few simple steps in selecting the necessary components for a given application.

### STEP 1 – CHOOSING A MOTOR SIZE (FORCE REQUIREMENTS)

Here is a general overview of the output thrust vs. motor size:

	Motor Sizes(mm)	Max Thrust(N)	Recommended Load Limit(N)
Hybrid stepper motor based linear actuators	20	70	45
	28	150	140
	35	300	230
	42	600	320
	57	1300	910
	86	2400	2270

### STEP 2 – CHOOSING A SCREW LEAD (FORCE AND SPEED REQUIREMENTS)

After estimating the required thrust and choosing a motor size that may fit your application, the speed and acceleration of the load must be considered and evaluated to choose an appropriate screw lead.

Due to the nature of lead screws, the output speed and output thrust achievable by a motor/lead screw combination are two inversely proportional variables. (i.e., increasing the required thrust will lower the achievable speed for a motor/lead screw combination). Therefore, the maximum output force of a system is lowered for applications that required higher speed.

For complete motor/lead screw selection data, please refer to the speed/thrust curves for each motor size.

Although these two steps provide a solid foundation in motor/lead screw selection, other variables must also be considered:

- Duty Cycle
- Desired Life of a System
- Environmental Considerations
- Positional Repeatability
- Acceptable Backlash
- Acceleration/Deceleration
- Driver Specifications
- Vertical or Horizontal

Because of the numerous variables involved in motor selection, it is highly recommended for users to proceed with physical testing to accurately determine the motor/lead screw combination required for a given application.

**NOTE:** Although this section aims to provide a rough guide to select a motor/lead screw combination that best fits an application, we recommend to contact our application engineering staff for further assistance with the motor selection process.

**FOR MORE INFORMATION, CONTACT YOUR LOCAL  
DINGS' REPRESENTATIVE (REFERENCE CATALOGUE BACK COVER)**



One of the most common methods of moving a load from point A to point B is through linear translation of a motor by a mechanical lead screw and nut. This section is here to assist and refresh your understanding of the basic principles of lead screw technology prior to selecting the system that is best for your application.

Some basic design consideration are as follows:

1. What is the load of your system?
2. What is the required speed to move from point A to point B?
3. What is the distance to be travelled?
4. What accuracy does your application require?
5. What is the required time to move from point A to point B?
6. What repeatability does your application require?
7. Horizontal vs vertical orientation?



### ● LINEAR ACTUATOR TYPES

## ■ TERMINOLOGY

### ● LEAD

Lead is the axial distance the nut advances on one revolution of the screw. Throughout this catalog, lead will be the term used for specifying a screw as it is the linear distance travelled for one revolutions of the screw. The larger the lead, the more linear distance travelled per one revolution of the screw.  $Lead = Pitch \times screw\ start$ .

### ● PITCH

Pitch is the axial distance between threads. Pitch is equal to lead in a single start screw. There may be more than one thread "strand" on a single screw. These are called starts. Multiple start lead screws are usually more stable and efficient at power transmission.

### ● ACCURACY OF SCREW

Specified as a measurement over a given length of the screw. For example: 0.004 inch per foot. Lead accuracy is the difference between the actual distance travelled versus the theoretical distance travelled based on the lead. For example: A screw with a 0.5 inch lead and 0.004 inch per foot lead accuracy rotated 24 times theoretically moves the nut 12 inches. However, with a lead accuracy of 0.004 inch per foot, actual travel could be from 11.996 to 12.004 inches.

### ● POSITION TOLERANCE

The approach value between actual distance travelled vs theoretical distance travelled.

### ● REPEATABILITY

Most motion applications put the most significance on the repeatability (vs accuracy of screw) of a system to reach the same commanded position over and over again.

### ● HORIZONTAL OR VERTICAL APPLICATION

Vertical orientation applications add the potential problem of backdriving when power to the motor is off and without an installed brake. Vertical application also have an additional gravity factor that must be part of the load/force calculation.

### ● TOTAL INDICATED RUNOUT

The amount of "wobble" around the centerline of the screw.

### ● TENSION OR COMPRESSION LOAD

A load that tends to stretch the screw is called a tension load.

A load that tends to "squeeze" or compress the screw is called a compression load.

Depending on the size of the load, designing the screw in tension utilizes the axial strength of the screw versus column loading.

### ● VIBRATION AND NOISE

The hybrid stepper motor's resonance will be occurred when pulse is up to 200PPS. Try starting your acceleration ramp at above these levels. Micro-stepping will also help through these ranges.

## Technology Overview

- **STATIC LOAD**

Load applied to the screw when the screw is still.

- **DRIVER**

Stepper motors require some external electrical components in order to run. These components typically include a power supply, logic sequencer, switching components and a clock pulse source to determine the step rate. Many commercially available drives have integrated these components into a complete package. Some basic drive units have only the final power stage without the controller electronics to generate the proper step sequencing.

- **DYNAMIC LOAD**

Load applied to the screw when the screw is moving.

- **HOLDING TORQUE**

When motor is static and rated current is applied to two phase, the stator's holding ability to the rotor.

- **ROTOR INERTIA**

Moment matter when accelerate or decelerate.

- **TRAVEL PER STEP**

The linear travel movement of one full step of the motor.

- **HEAT RISING**

Motor body's temperature rising after certain periods running and heat exchange with the ambient.

- **RESPONSE PER STEP**

Times takes to complete one step.

- **STEP**

Characteristics of stepper motor that the rotor moves step by step as the stator commutates phase by phase.

- **STEP ANGLE**

Angular movement of every step.

- **PULL OUT TORQUE**

Under certain drive condition (frequency and current), the max load that the motor can drag until missing step

- **PULL IN TORQUE**

When couples and accelerates, the max load torque (including frictions) that the motor can bear and start.

- **EFFICIENCY**

The ability of a mechanical system to translate an input to an equal output.

- **RESOLUTION**

Incremental linear distance the actuator's (motor) output shaft will move per input pulse.



### ● TENSION OR COMPRESSION LOADING

A load that tends to stretch the screw is called a tension load.

A load that tends to “squeeze” or compress the screw is called a compression load.

Depending on the size of the load, designing the screw in tension utilizes the axial strength of the screw versus column loading.

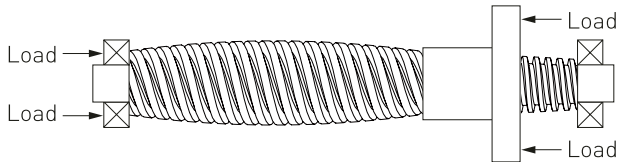

Compression Loading

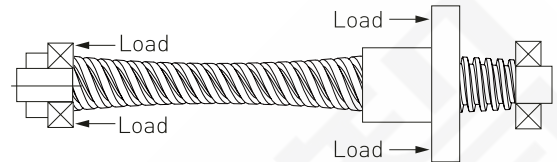

Tension Loading

### ● RADIAL LOAD

A load perpendicular to the screw.

This is not recommended unless additional mechanical support such as a linear guide is used.

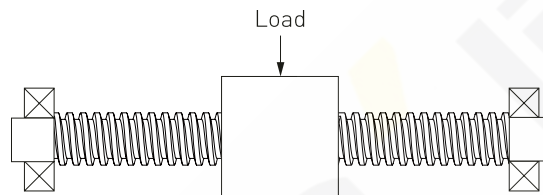

Radial Loading  
(Avoid or Minimize)

### ● AXIAL LOAD

A load that exerted at the center line of the lead screw.

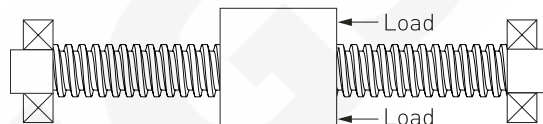

Axial Center Loading  
(best)

### ● STATIC LOAD

The maximum thrust load, including shock load, that should be applied to a non-moving screw.

### ● DYNAMIC LOAD

The maximum recommended thrust load which should be applied to the screw while in motion.

### ● BACKDRIVING

Backdriving is the result of the load pushing axially on the screw or nut to create rotary motion. Generally, a nut with an efficiency greater than 50% will have a tendency to backdrive. Selecting a lead screw with an efficiency below 35% may prevent backdriving. The smaller the lead, the less chance for backdriving or free wheeling. Vertical application are more prone to backdriving due to gravity.

### ● TORQUE

The required motor torque to drive just the lead screw assembly is the total of:

1. Inertial Torque
2. Drag Torque (friction of the nut and screw in motion)
3. Torque to move load

### ● LUBRICATION

The nut material contains a self-lubricating material that eliminates the need for adding a lubricant to the system. The Teflon coated screw option also lowers friction and extends life of the system.

### ● END MACHINING OF THE SCREW (Please refer to A-40)

Standard metric or English option are available. Custom end machining specifications are also available on request. Please contact your local DINGS' representative.

## Technology Overview

### ● FIXITY

The performance (speed and efficiency) of the screw system is affected by how the screw ends are attached and supported.

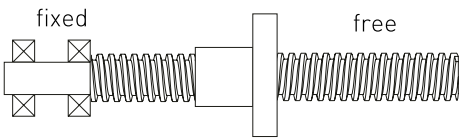
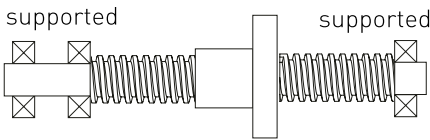
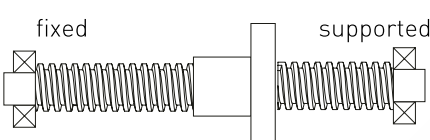
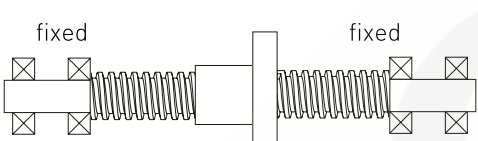
Type of End Fixity	Relative Rigidity	Critical Speed Factor	Critical Load Factor
 <p>fixed free</p>	Less Rigid	0.32	0.25
 <p>supported supported</p>	Rigid	1.0	1.0
 <p>fixed supported</p>	More Rigid	1.55	2.0
 <p>fixed fixed</p>	Most Rigid	2.24	4.0

### ● COLUMN STRENGTH

When a screw is loaded in compression, its limit of elastic stability can be exceeded and the screw will fail due to bending or buckling.

### ● CRITICAL SPEED

Critical speed is the rotational speed of the screw at which the first harmonic of resonance is reached due to deflection of the screw. A system will vibrate and become unstable at these speeds.

Several variables affect how quickly the system will reach critical speed:

1. The lead of the screw
2. The rotational speed
3. End fixity
4. Thrust load
5. Diameter of the screw
6. Tension or compression loading

For example, the following chart shows that for a screw with a 3/4 inch diameter and 70 inch length, the threshold for critical speed is 700RPM.

● **CRITICAL ROTATION SPEED (RPM) VS. UNSUPPORTED SCREW LENGTH FOR VARIOUS SCREW DIAMETERS (INCH)**

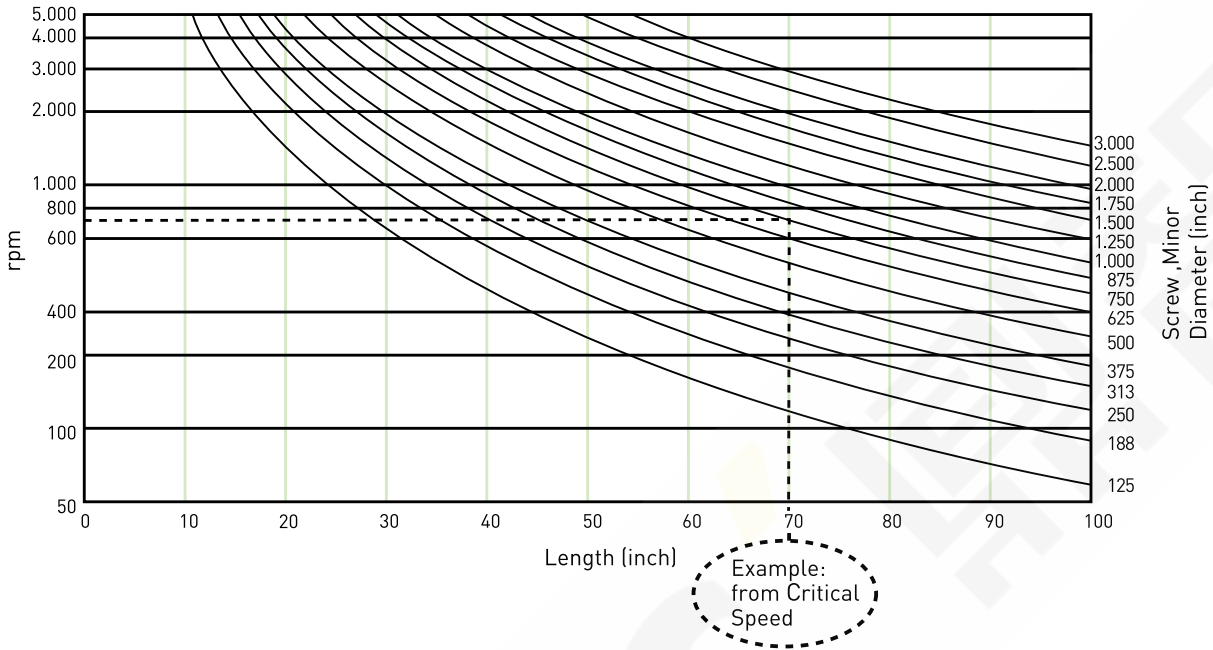

● **BACKLASH**

Backlash is the relative axial movement between a screw and nut at standstill. It is normal for backlash to increase with wear over time. Backlash compensation or correction can be accomplished through the application of an anti-backlash nut. Backlash is usually only a concern with bi-directional positioning.

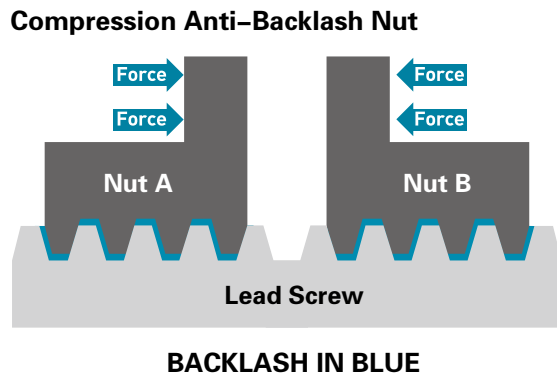
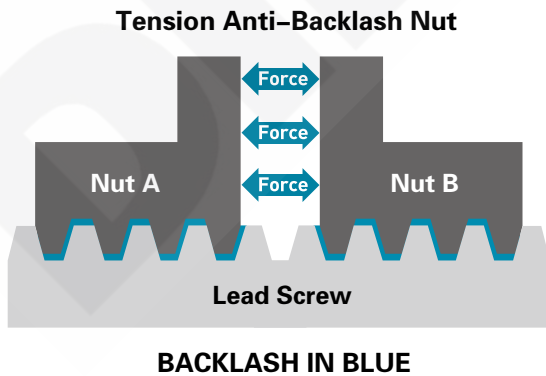
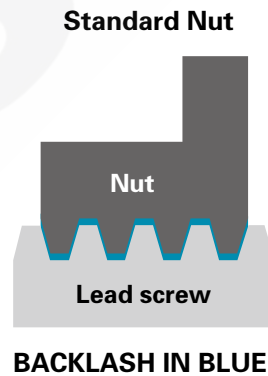



# Technology Overview

## ■ STEPPING SEQUENCE

### BIPOLAR

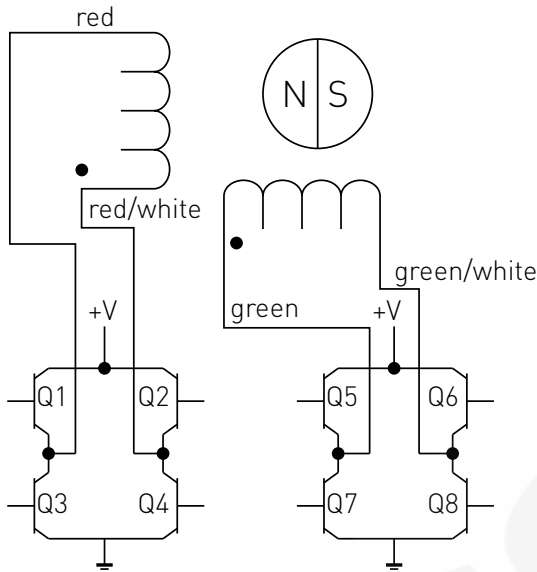

### UNIPOLAR

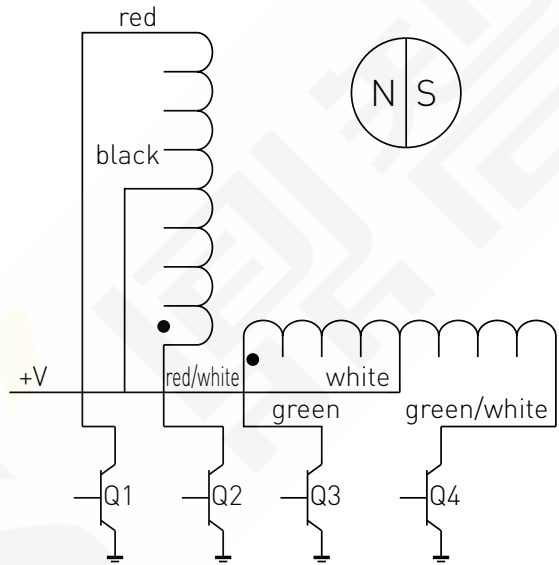

	Bipolar	Q2-Q3	Q1-Q4	Q6-Q7	Q5-Q8
	Unipolar	Q1	Q2	Q3	Q4
	Step				
→extend CW→	1	ON	Off	ON	Off
	2	Off	ON	ON	Off
	3	Off	ON	Off	ON
	4	ON	Off	Off	ON
	5	ON	ON	Off	Off
					→retract CCW→

Unless otherwise noted, all reference to lead screws in this catalog have the following characteristics

<b>Lead Screw Material</b>	303 Stainless precision cold rolled steel
<b>Screw Coating</b>	Teflon coating is optional
<b>Standard Screw Accuracy (Lead accuracy)</b>	0.0071 inch per foot (0.18mm per 300mm)
<b>Screw Straightness</b>	0.08 inch/foot, measured as Total Indicated Runout(TIR). All screws are carefully checked for straightness before shipment.
<b>Screw Efficiency</b>	From 35% to 85% dependent on lead. Also depends on the usage of an anti-backlash nut with screw. The larger the lead, the higher the efficiency of the screw.
<b>Operating Temperature</b>	-20°C to + 50°C
<b>Storage Temperature</b>	-20°C to + 50°C , keep in dry
<b>Screw Backlash</b>	0.01mm~0.1mm, depends on different lead. Anti-backlash nut should be considered for high bi-directional positioning repeatability.
<b>System Backlash</b>	Includes screw, motor, and attached mechanics. This will be the sum of all the backlash in your motion axis.
<b>Nut Material</b>	Polyacetal with lubricating additive; Standard is a free-wheeling nut. (Anti-backlash version is available)
<b>Wear Life of Screw and Nut</b>	Depends on load, speed, duty cycle, and environmental factors (typically $\geq$ 5 million cycles)

**NOTE:** DINGS' linear system are manufactured from high quality materials. Because of the variable effects of friction, lubrication, and cleanliness, an exact life cannot be predicted for a given applications.

**FOR MORE INFORMATION, CONTACT YOUR LOCAL DINGS' REPRESENTATIVE  
(REFERENCE CATALOGUE BACK COVER)**



## Size 8 (20mm) Series

BACK TO

The size 8 is our smallest hybrid linear actuators. This compact unit can be integrated into various applications to provide precise linear positioning while occupying less than 1 in<sup>2</sup> of mounting footprint and providing up to 44.5N of continuous thrust.



### Motor Characteristics

Motor	Voltage (V)	Current (A)	Resistance (Ω)	Inductance (mH)	Weight (g)	Lead Wire No.	Motor Length (mm)
8-2105	2.5	0.5	5.1	1.5	51	4	27.2
8-2205	4.4	0.5	8.8	2.7	74	4	38.1

### Available Lead Screw and Travel per Step

Screw Dia. (inch)	Screw Dia. (mm)	Lead (inch)	Lead (mm)	Lead Code	Travel Per Step @ 1.8 deg (mm)*
0.138	3.5	0.012	0.3000	AF	0.0015
0.138	3.5	0.024	0.6096	AA	0.0030
0.138	3.5	0.039	1.0000	AB	0.0020
0.138	3.5	0.048	1.2192	B	0.0061
0.138	3.5	0.079	2.0000	G	0.0100
0.138	3.5	0.158	4.0000	M	0.0200
0.138	3.5	0.315	8.0000	T	0.0400

Value truncated

### Dimensional Drawings

#### External Actuator

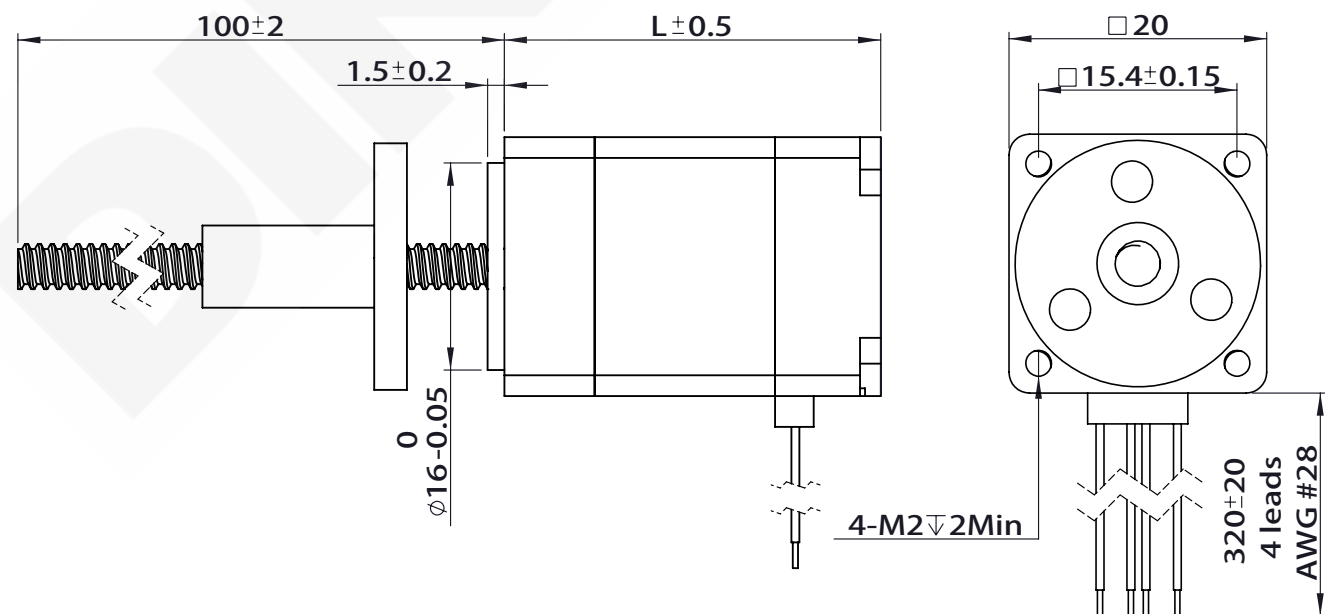

**Size 8 (20mm) Series**

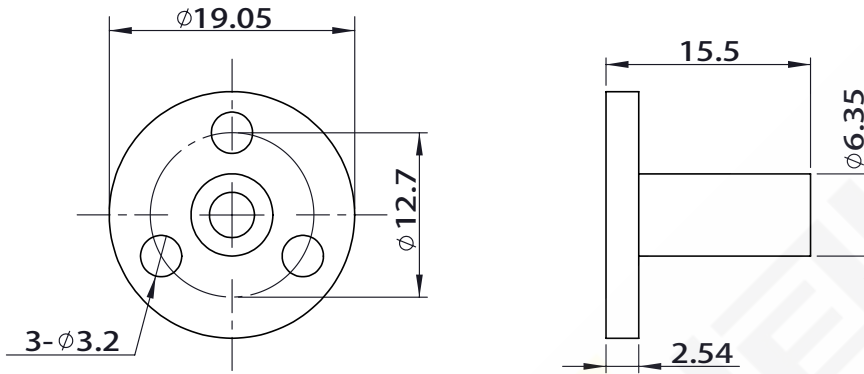

**Non-Captive Actuator**

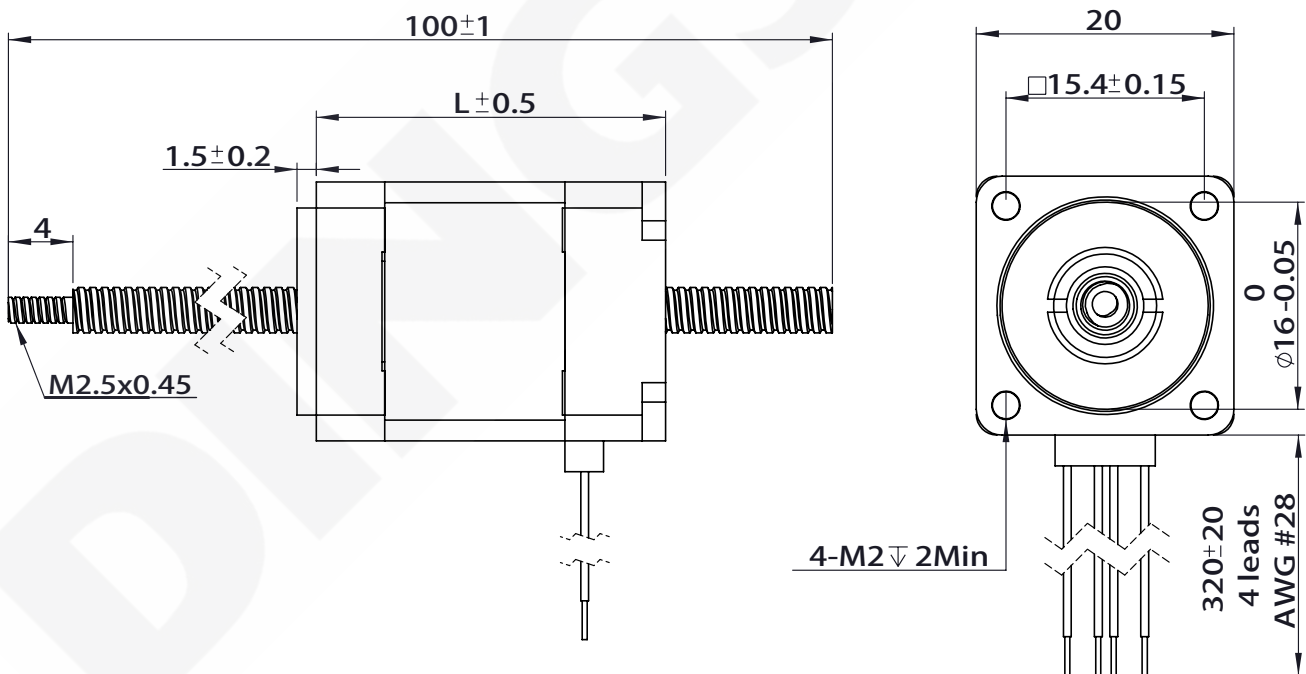

**NOTE:** All drawings are First Angle Projection - ISO Standard. [3D Models are available].



## Size 8 (20mm) Series

### Kaptive Actuator

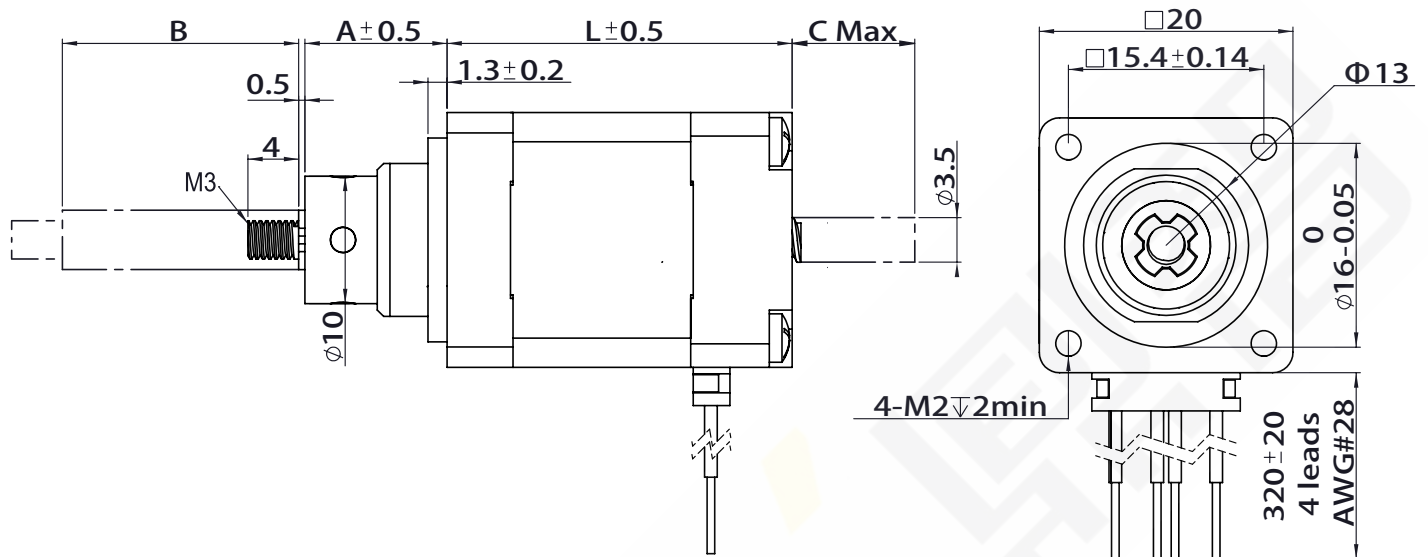

#### ● Stroke Specification

A (mm)	Stroke B (mm)	C (mm)	
		L=27.2	L=38.1
11.20	9.00	1	0
14.90	12.70	5	0
21.10	19.05	11	0
27.60	25.40	17	6
34.00	31.80	24	13
40.30	38.10	30	19

**Size 8 (20mm) Performance Curves**

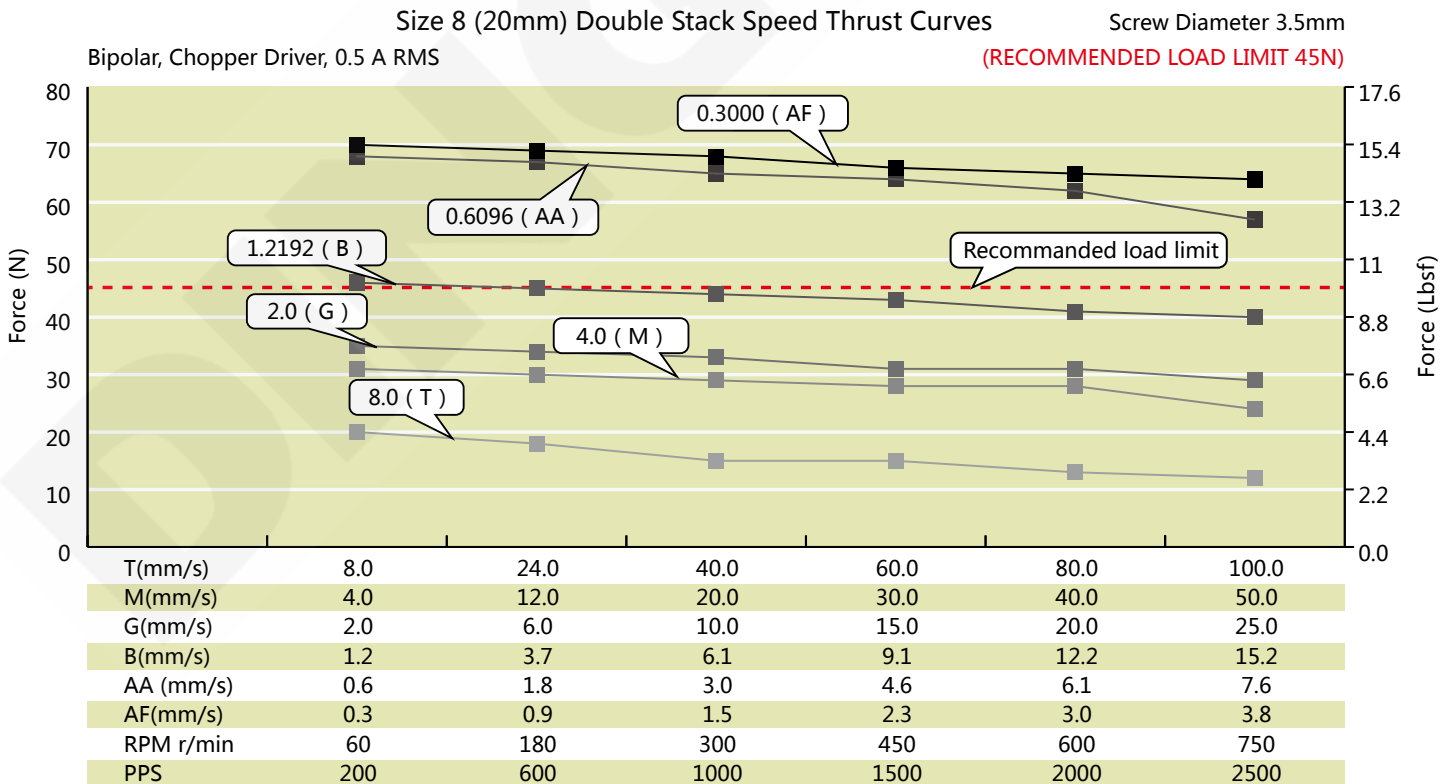
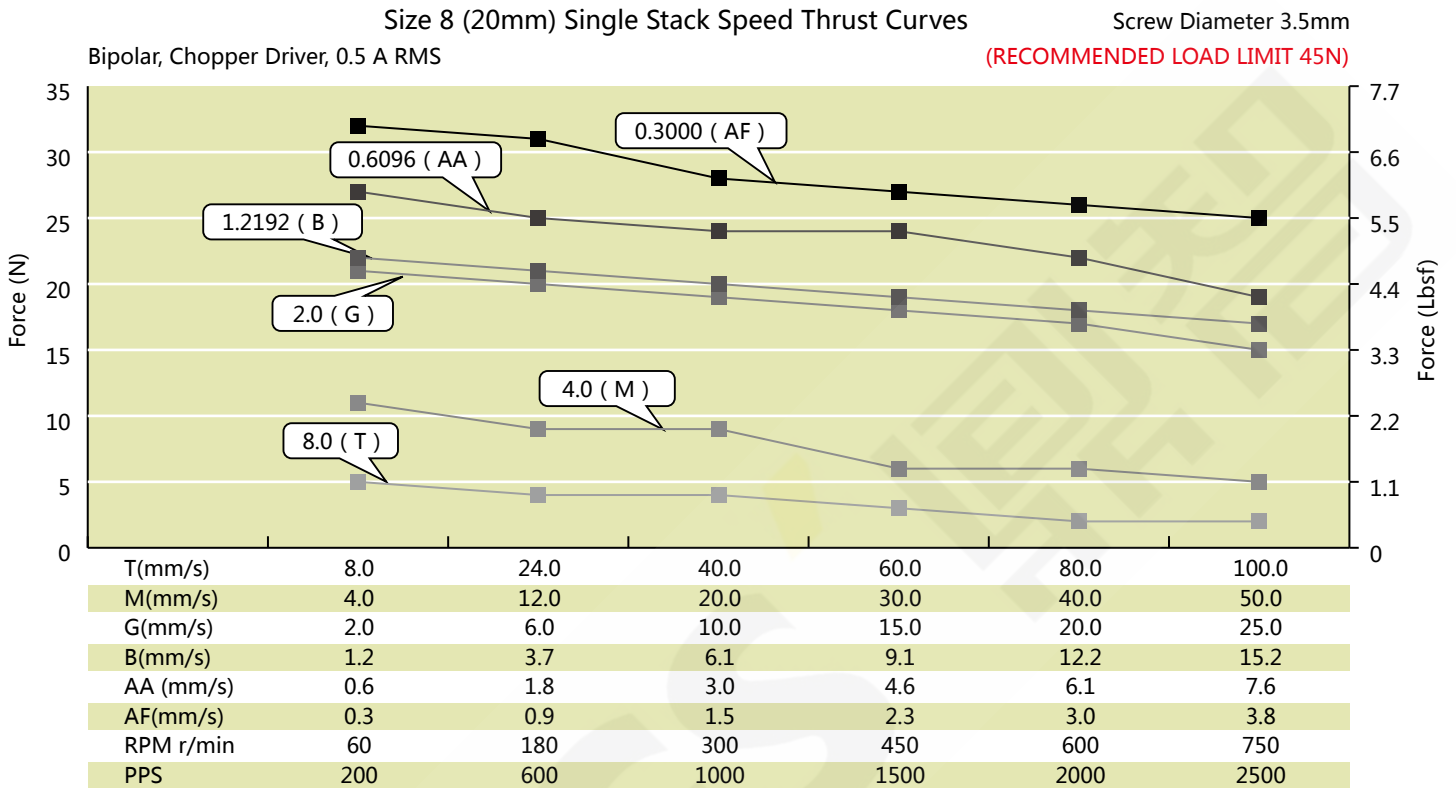

**TEST CONDITION:**

Testing Voltage: 24VDC, Driver Model: DS-2422-001, at rated current (rms) pull-in thrust. Motor's thrust will be changed with different voltage and driver. 50% thrust margin is recommended.

## Size 11 (28mm) Series

BACK TO

The size 11 hybrid linear actuator occupies a mounting footprint of slightly above 1 in<sup>2</sup> but provides over 3X the continuous thrust of size 8.

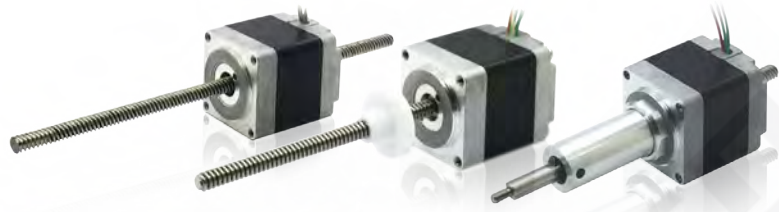

### Motor Characteristics

Motor	Voltage (V)	Current (A)	Resistance (Ω)	Inductance (mH)	Weight (g)	Lead Wire No.	Motor Length (mm)
11-2105	4.5	0.5	9.1	6.0	117	4	33.5
11-2110	2.2	1.0	2.1	1.5	117	4	33.5
11-2209	3.9	0.95	4.1	4.0	173	4	45
11-2216	2.4	1.6	1.5	1.3	173	4	45

### Available Lead Screw and Travel per Step

Screw Dia. (inch)	Screw Dia. (mm)	Lead (inch)	Lead (mm)	Lead Code	Travel Per Step @ 1.8 deg (mm)*
0.188	4.77	0.013	0.318	AL	0.0016
0.188	4.77	0.025	0.635	A	0.0032
0.188	4.77	0.050	1.270	D	0.0063
0.218	5.56	0.096	2.438	J	0.0122
0.188	4.77	0.100	2.540	K	0.0127
0.218	5.56	0.192	4.877	Q	0.0244
0.188	4.77	0.200	5.080	R	0.0254
0.188	4.77	0.400	10.160	X	0.0508

Value truncated

### Dimensional Drawings

#### External Actuator

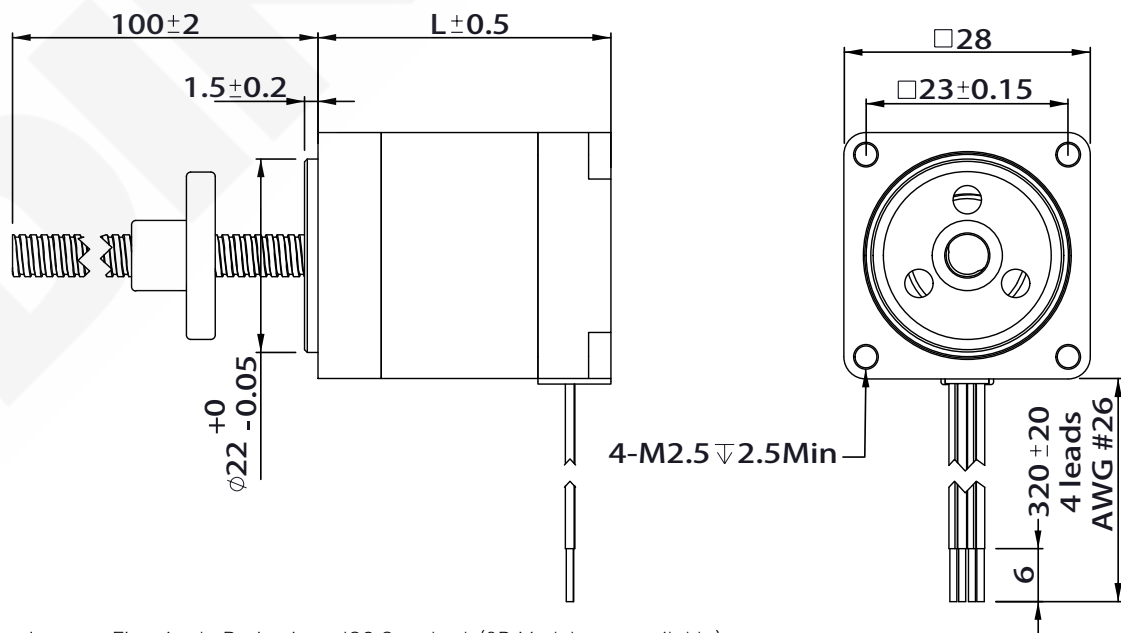



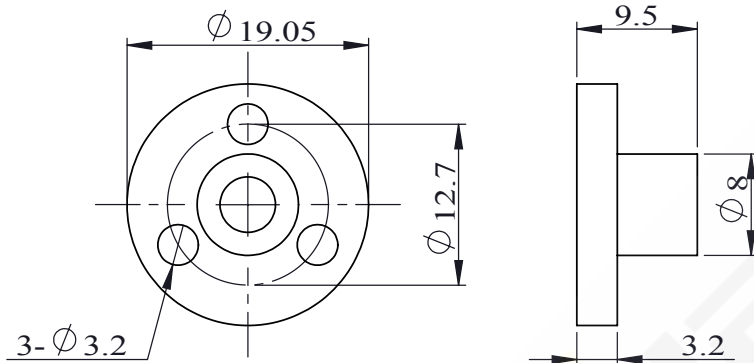

**Non-Captive Actuator**

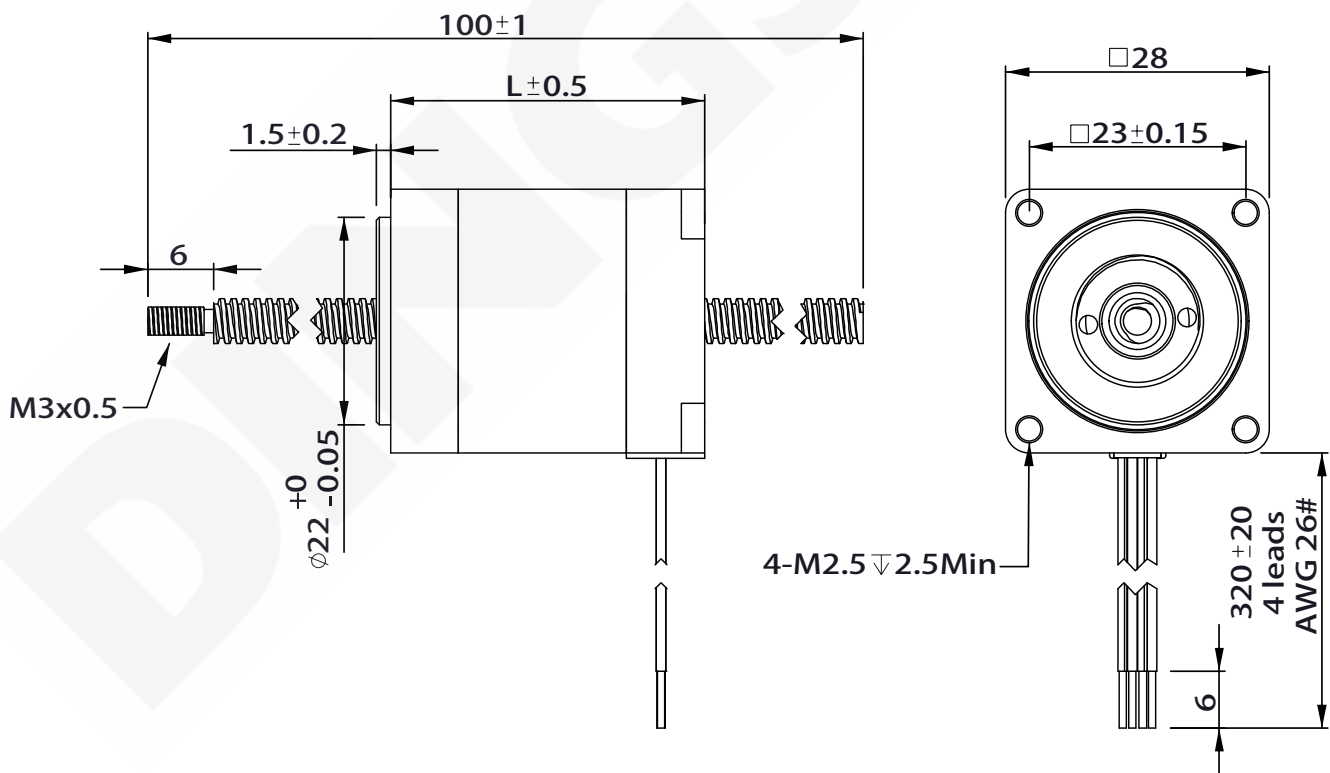

**NOTE:** All drawings are First Angle Projection – ISO Standard. [3D Models are available].

## Size 11 (28mm) Series

### Kaptive Actuator

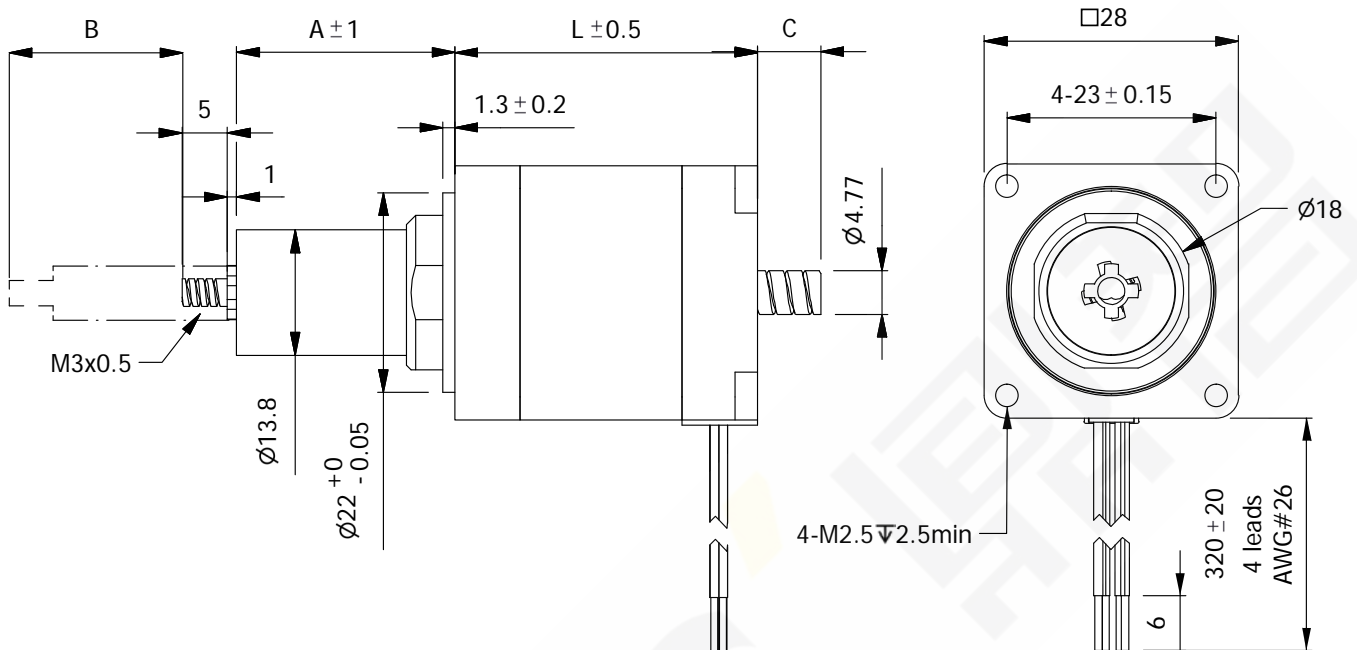

#### ● Stroke Specification

A (mm)	Stroke B (mm)	C (mm)	
		L=33.3	L=45
15.70	12.70	1.0	0.0
22.10	19.05	7.4	0.0
28.40	25.40	13.7	4.0
34.80	31.80	20.1	10.4
41.10	38.10	26.4	16.8
53.80	50.80	39.0	29.4
66.50	63.50	52.7	42.1

## Size 11 (28mm) Series

### Size 11 (28mm) Performance Curves

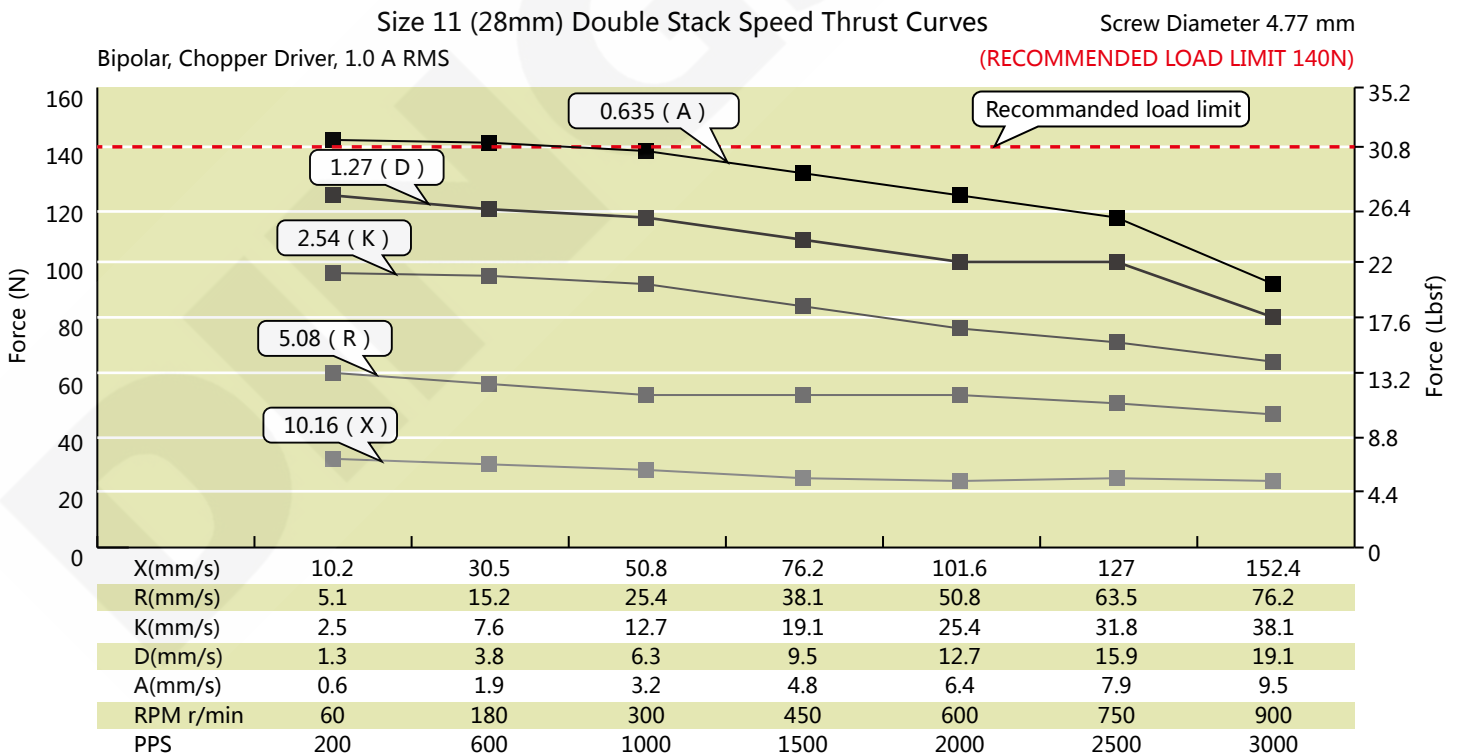
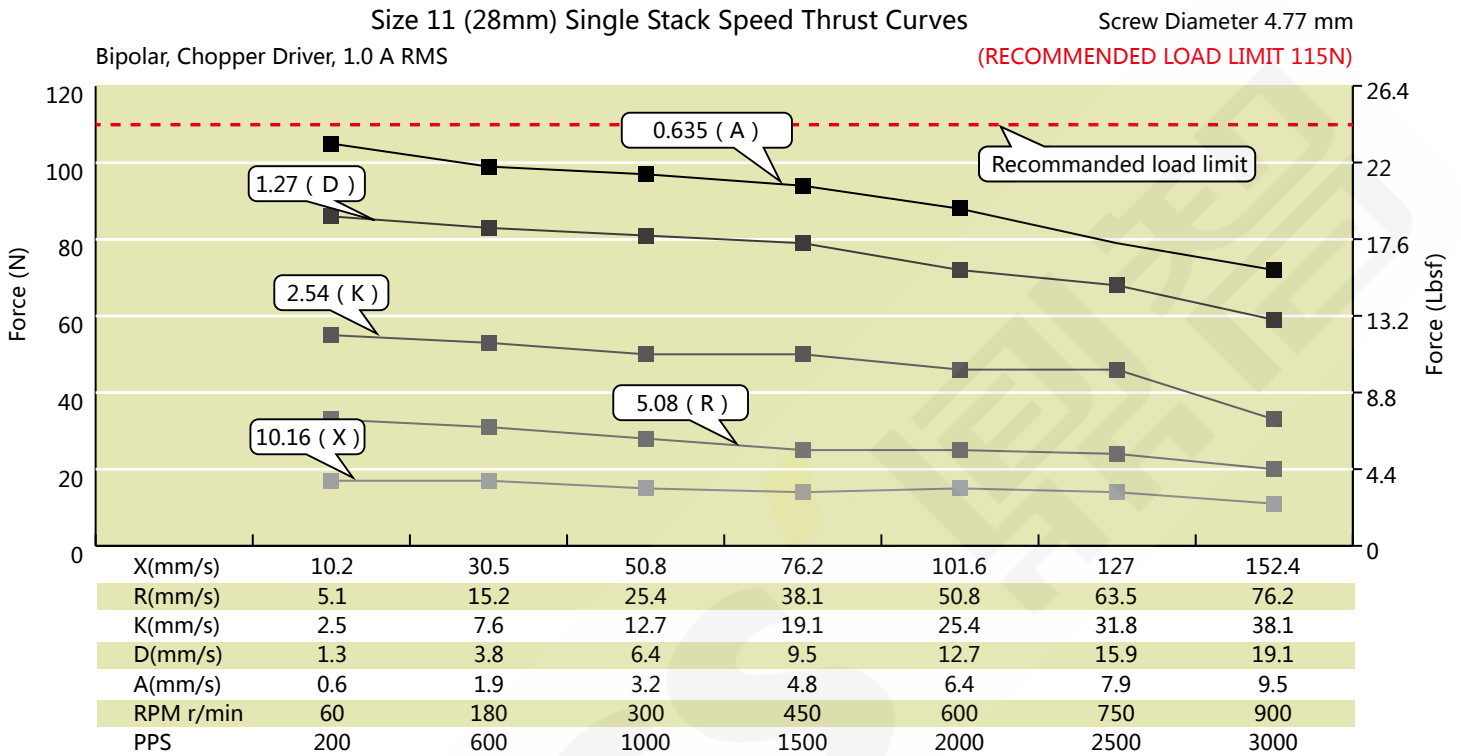

**TEST CONDITION:**

Testing Voltage: 24VDC, Driver Model: DS-2422-001, at rated current (rms) pull-in thrust. Motor's thrust will be changed with different voltage and driver. 50% thrust margin is recommended.



## Size 14 (35mm) Series

[BACK TO](#)

The size 14 Hybrid precision linear actuator is the mostly used for linear movement applications, provides up to 230N of continuous thrust.



### Motor Characteristics

Motor	Voltage (V)	Current (A)	Resistance ( $\Omega$ )	Inductance (mH)	Weight (g)	Lead Wire No.	Motor Length (mm)
14-2105	6.6	0.5	13.2	14.0	189	4	33.6
14-2110	3.3	1.0	3.5	3.6	189	4	33.6
14-2115	2.2	1.5	1.8	1.9	189	4	33.6
14-2205	12.0	0.5	24.0	29.0	210	4	45.6
14-2210	6.0	1.0	6.0	7.2	210	4	45.6
14-2215	4.0	1.5	2.7	3.2	210	4	45.6

### Available Lead Screw and Travel per Step

Screw Dia. (inch)	Screw Dia. (mm)	Lead (inch)	Lead (mm)	Lead Code	Travel Per Step @ 1.8 deg (mm)*	Travel Per Step @ 0.9 deg (mm)*
0.25	6.35	0.024	0.6096	AA	0.0030	0.0015
0.25	6.35	0.039	1.0000	AB	0.0050	0.0025
0.25	6.35	0.048	1.2192	B	0.0060	0.0030
0.25	6.35	0.050	1.2700	D	0.0060	0.0032
0.25	6.35	0.063	1.5875	F	0.0080	0.0040
0.25	6.35	0.096	2.4384	J	0.0120	0.0061
0.25	6.35	0.100	2.5400	K	0.0130	0.0064
0.25	6.35	0.125	3.1750	L	0.0160	0.0079
0.25	6.35	0.192	4.8768	Q	0.0240	0.0122
0.25	6.35	0.250	6.3500	S	0.0320	0.0159
0.25	6.35	0.333	8.4667	U	0.0420	0.0210
0.25	6.35	0.384	9.7536	W	0.0490	0.0244
0.25	6.35	0.500	12.7000	Y	0.0640	0.0318

Value truncated

**Dimensional Drawings**  
**External Actuator**

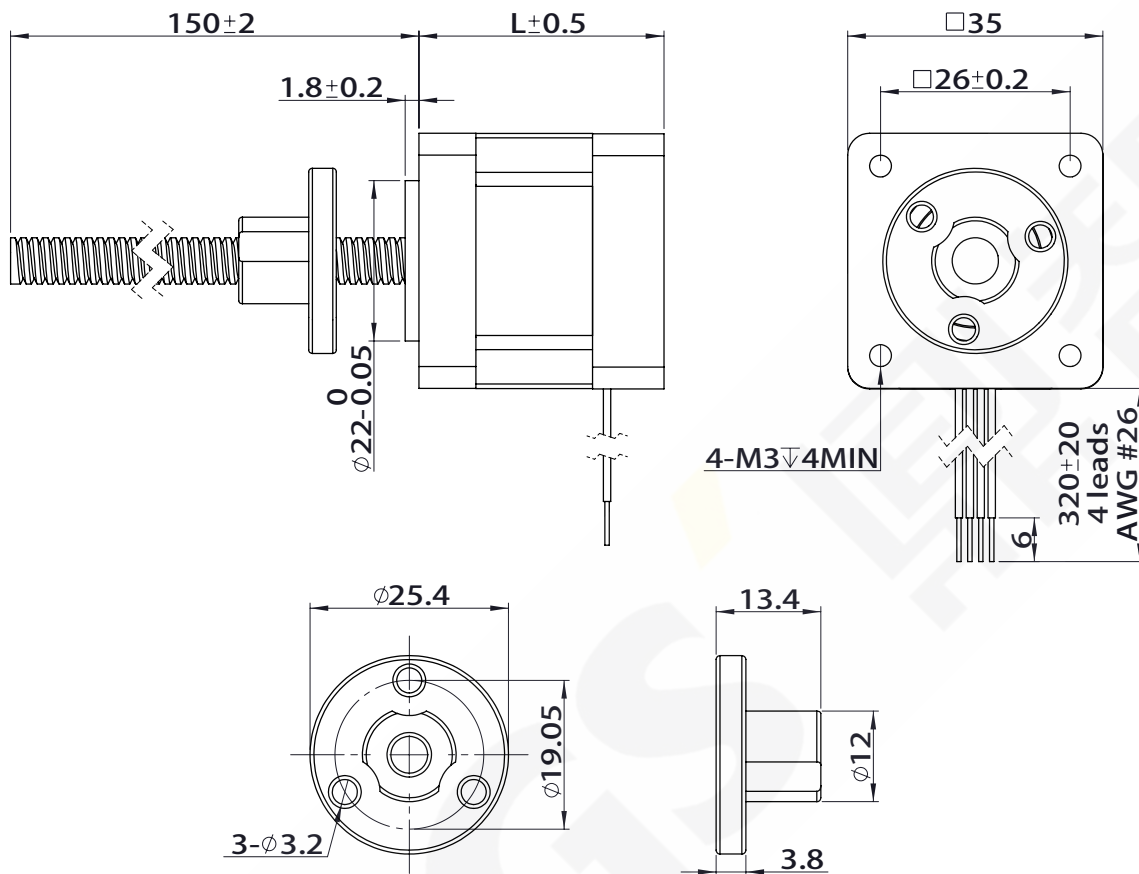

**Non-Captive Actuator**

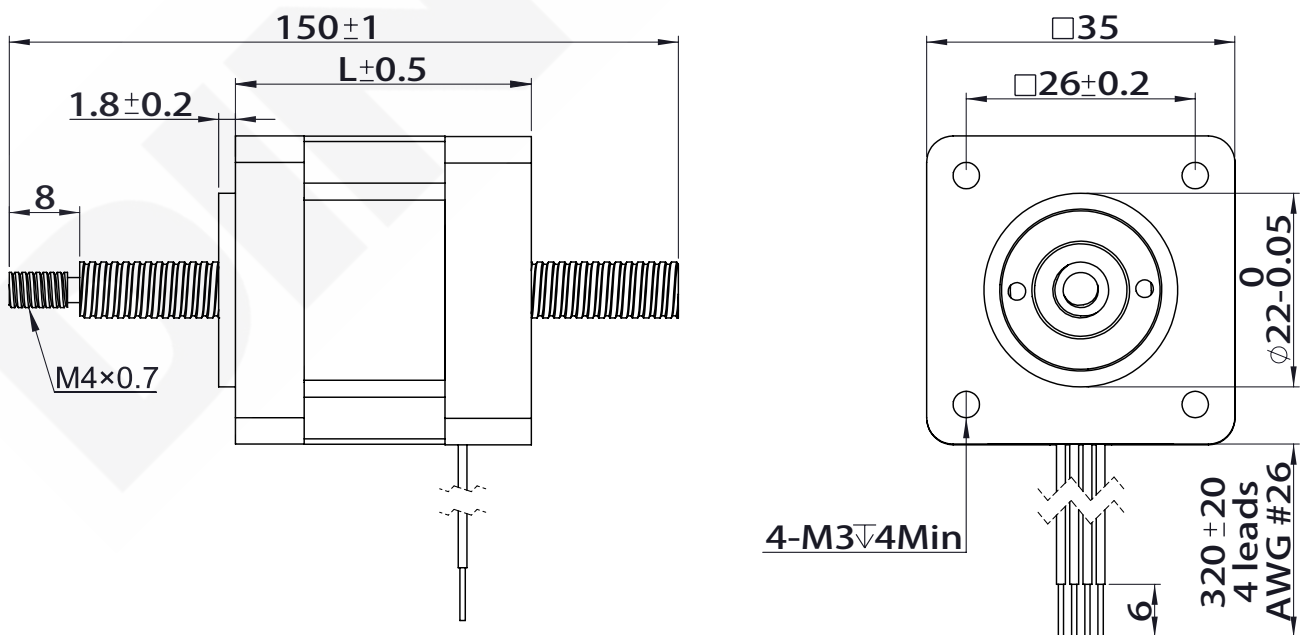

**NOTE:** All drawings are First Angle Projection - ISO Standard. [3D Models are available].

## Size 14 (35mm) Series

### Captive Actuator

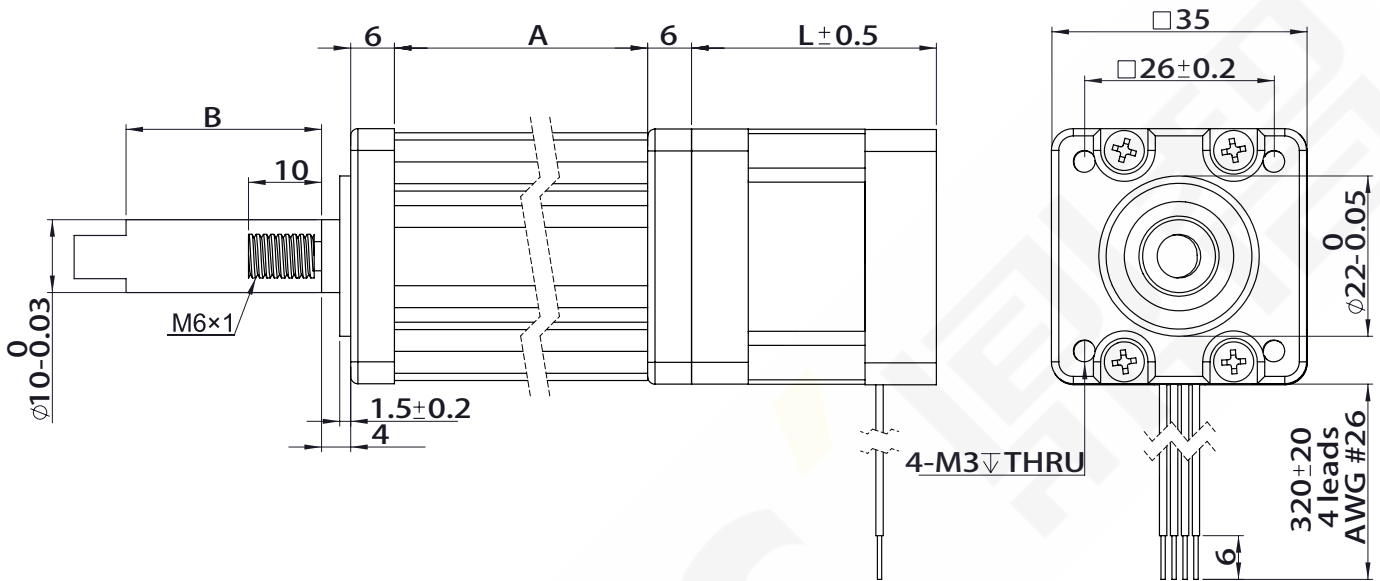

#### Stroke Specification

Stroke B inch (mm)	A (mm)	L (mm)	
0.50 (12.70)	35.70	Single Stack Motor 33.6mm	Double Stack Motor 45.6mm
0.75 (19.05)	42.05		
1.00 (25.40)	48.40		
1.25 (31.80)	54.80		
1.50 (38.10)	61.10		
2.00 (50.80)	73.80		
2.50 (63.50)	86.50		



**Kaptive Actuator**

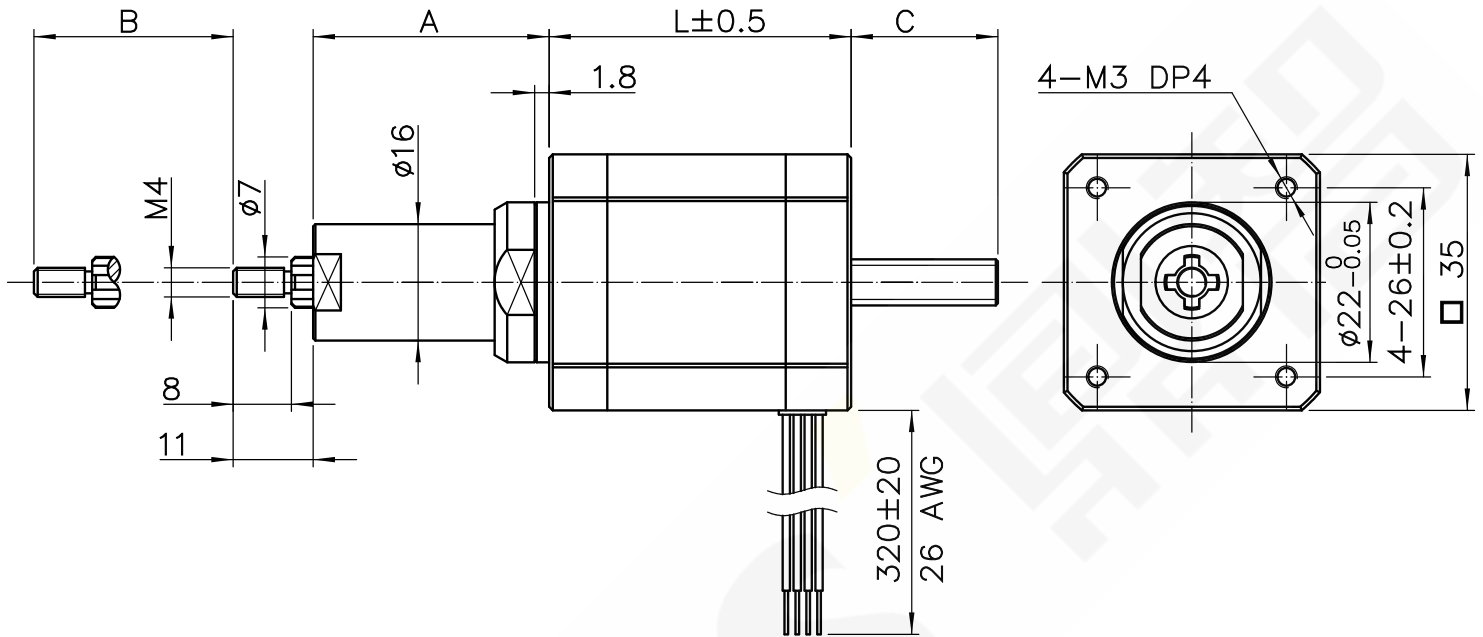

● **Stroke Specification**

Stroke B (mm)	A (mm)	C (mm)	
		L=33.6mm	L=45.6mm
12.70	18.70	4.30	1.30
19.05	25.05	10.65	7.65
25.40	31.40	17.00	14.00
31.75	37.75	23.35	20.35
38.10	44.10	29.70	26.70
50.80	56.80	42.40	39.40
63.50	69.50	55.10	52.10

## Size 14 (35mm) Series

### Size 14 (35mm) Performance Curves

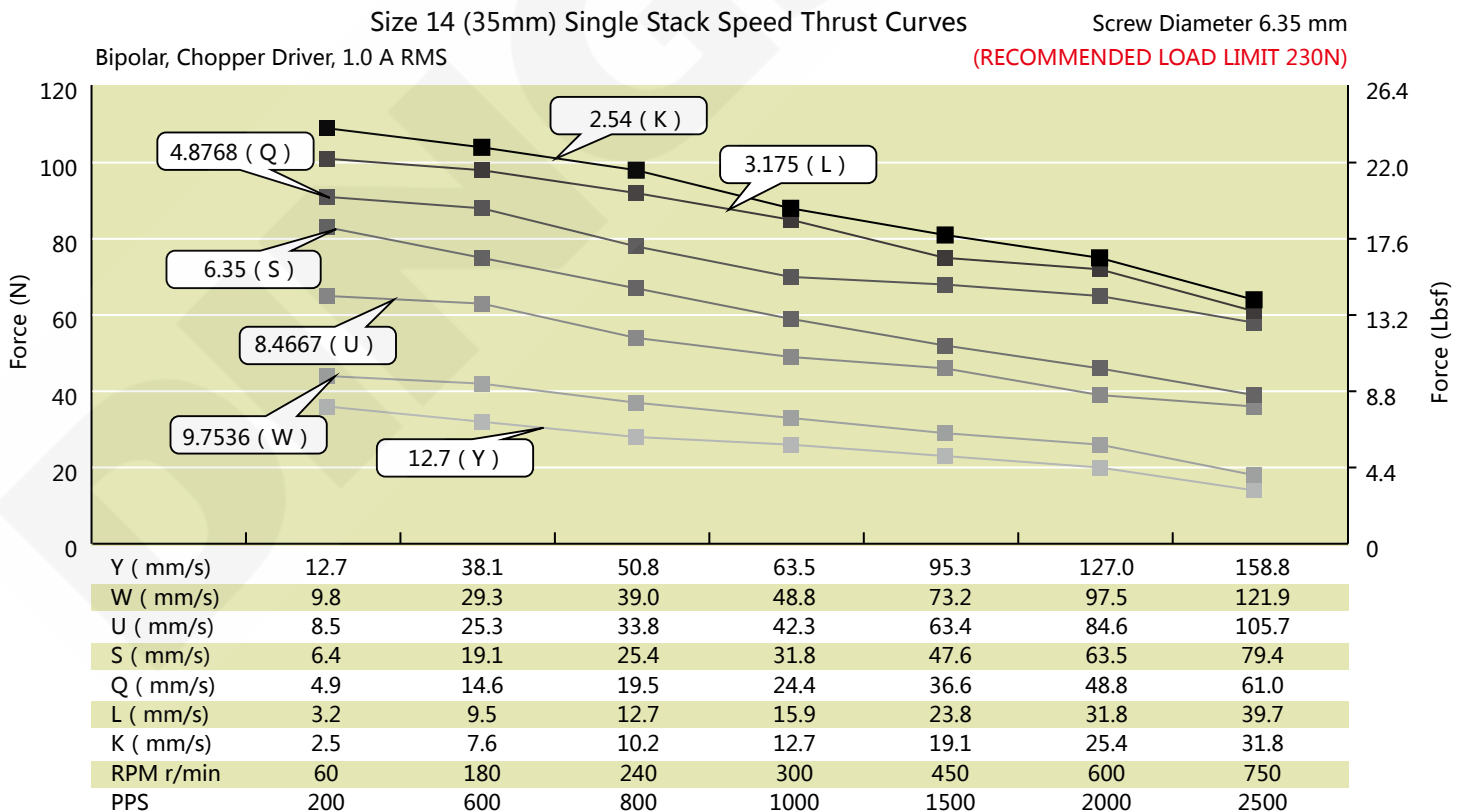
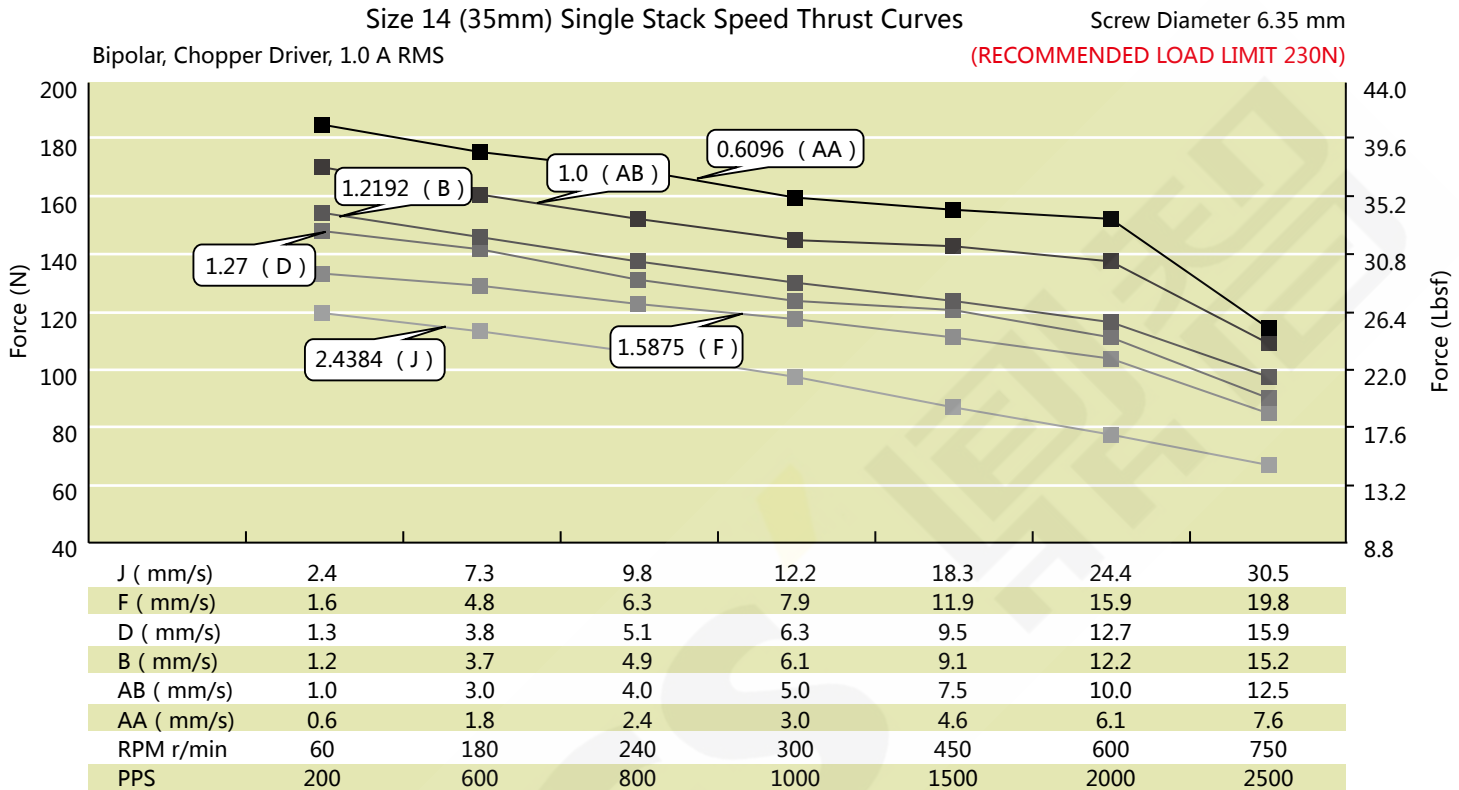

#### TEST CONDITION:

Testing Voltage: 24VDC, Driver Model: DS-2422-001, at rated current (rms) pull-in thrust. Motor's thrust will be changed with different voltage and driver. 50% thrust margin is recommended.

## Size 14 (35mm) Series

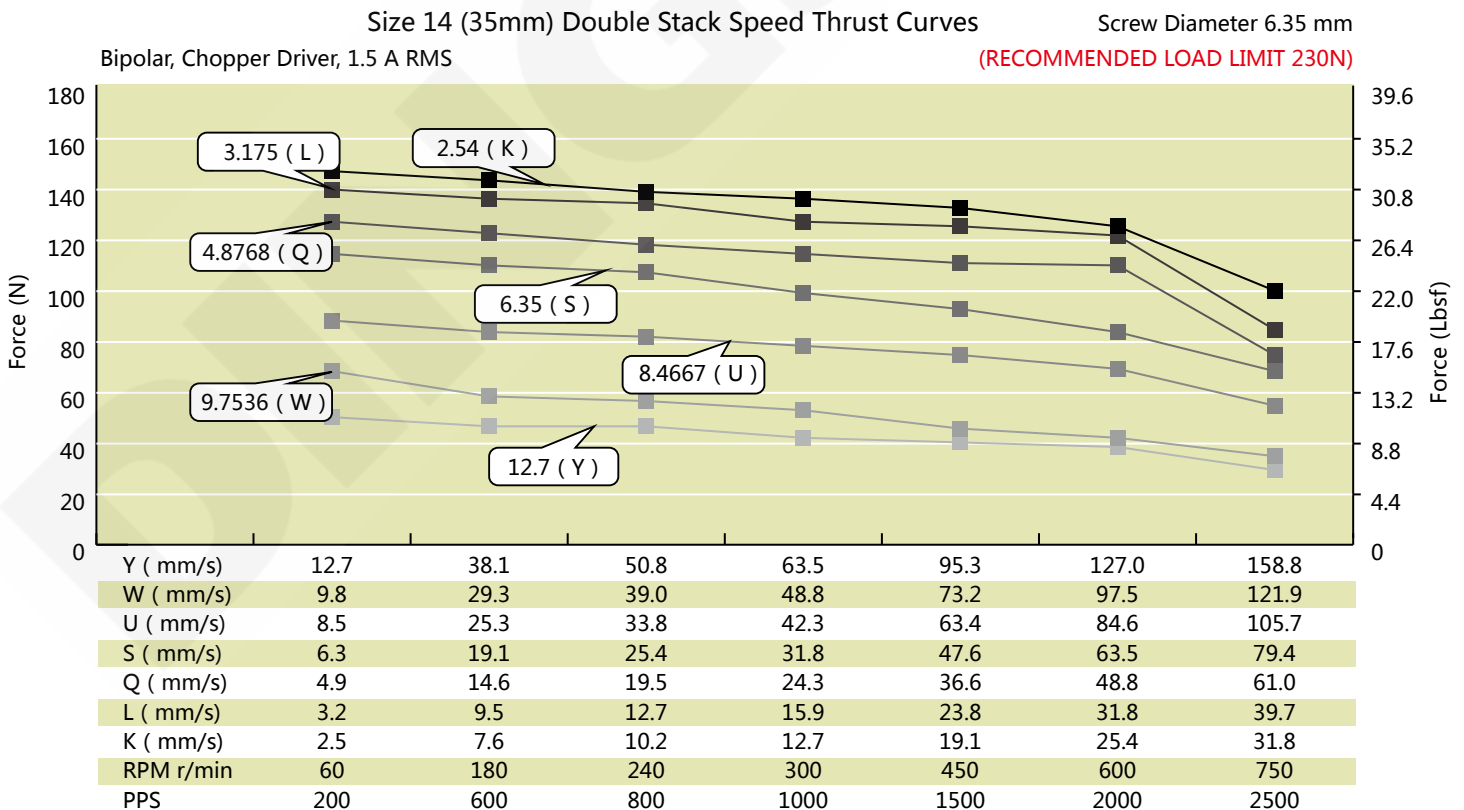
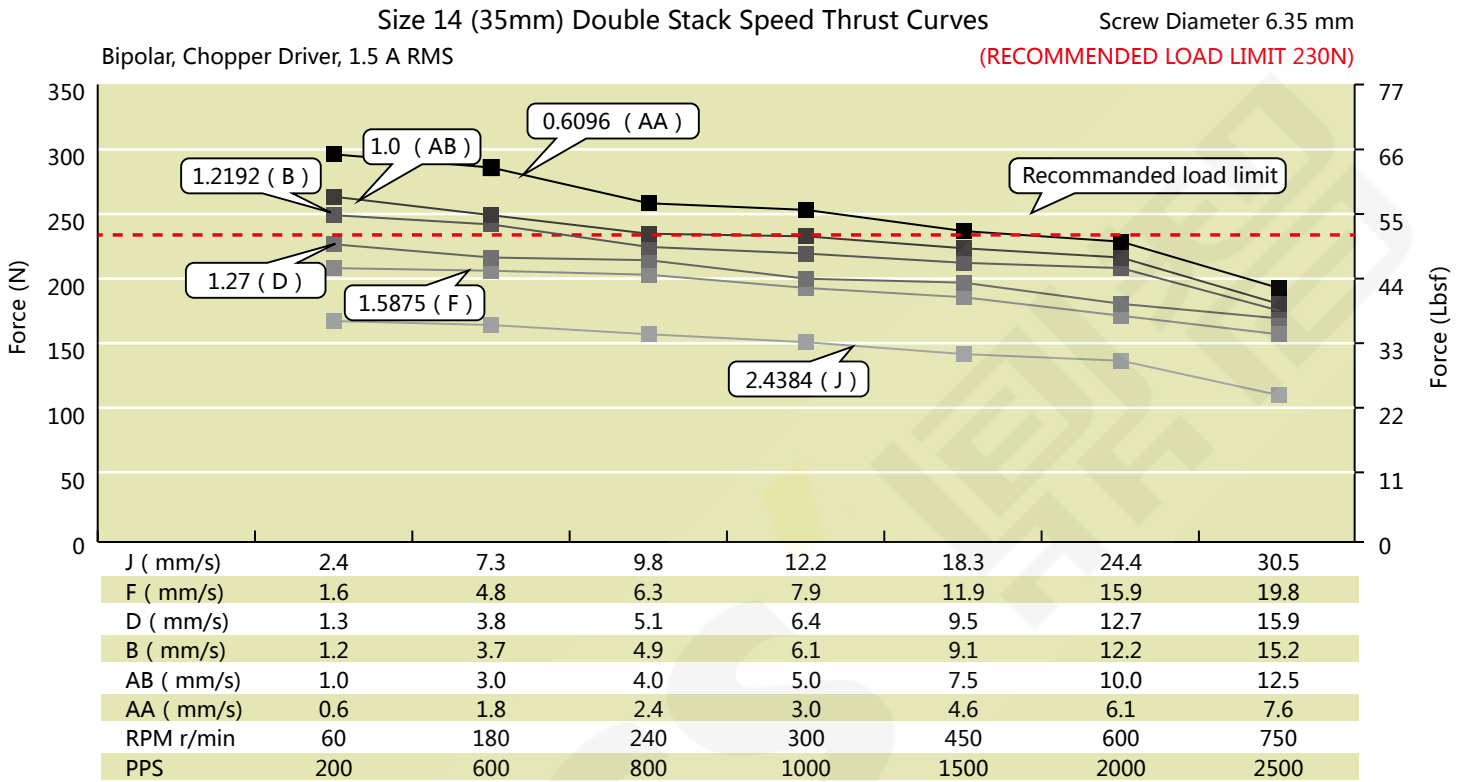

**TEST CONDITION:**

Testing Voltage: 24VDC, Driver Model: DS-2422-001, at rated current (rms) pull-in thrust. Motor's thrust will be changed with different voltage and driver. 50% thrust margin is recommended.



## Size 17 (42mm) Series

**BACK TO**

The size 17 Hybrid precision linear actuator is the mostly used for linear movement applications, provides up to 330N of continuous thrust.



### Motor Characteristics

Motor	Voltage (V)	Current (A)	Resistance ( $\Omega$ )	Inductance (mH)	Weight (g)	Lead Wire No.	Motor Length (mm)
17-2105	7.2	0.5	14.4	19.8	254	4	34.1
17-2110	3.6	1.0	3.6	5.0	254	4	34.1
17-2115	2.4	1.5	1.9	2.2	254	4	34.1
17-2205	11.0	0.5	22.0	46.0	386	4	48.1
17-2212	4.5	1.2	3.8	8.0	386	4	48.1
17-2225	2.2	2.5	0.9	1.8	386	4	48.1

### Available Lead Screw and Travel per Step

Screw Dia. (inch)	Screw Dia. (mm)	Lead (inch)	Lead (mm)	Lead Code	Travel Per Step @ 1.8 deg (mm)*	Travel Per Step @ 0.9 deg (mm)*
0.25	6.35	0.024	0.6096	AA	0.0030	0.0015
0.25	6.35	0.039	1.0000	AB	0.0050	0.0025
0.25	6.35	0.048	1.2192	B	0.0060	0.0030
0.25	6.35	0.050	1.2700	D	0.0060	0.0032
0.25	6.35	0.063	1.5875	F	0.0080	0.0040
0.25	6.35	0.096	2.4384	J	0.0120	0.0061
0.25	6.35	0.100	2.5400	K	0.0120	0.0064
0.25	6.35	0.125	3.1750	L	0.0160	0.0079
0.25	6.35	0.192	4.8768	Q	0.0240	0.0122
0.25	6.35	0.250	6.3500	S	0.0310	0.0159
0.25	6.35	0.333	8.4667	UA	0.0420	0.0210
0.25	6.35	0.384	9.7536	W	0.0480	0.0244
0.25	6.35	0.500	12.7000	Y	0.0640	0.0318
0.31	8.00	0.175	4.0000	MM	0.0200	0.0100
0.31	8.00	0.315	8.0000	MT	0.0400	0.0200
0.31	8.00	0.079	2.0000	G	0.0100	0.0050

Value truncated

**Size 17 (42mm) Series**

**Dimensional Drawings**  
**External Actuator**

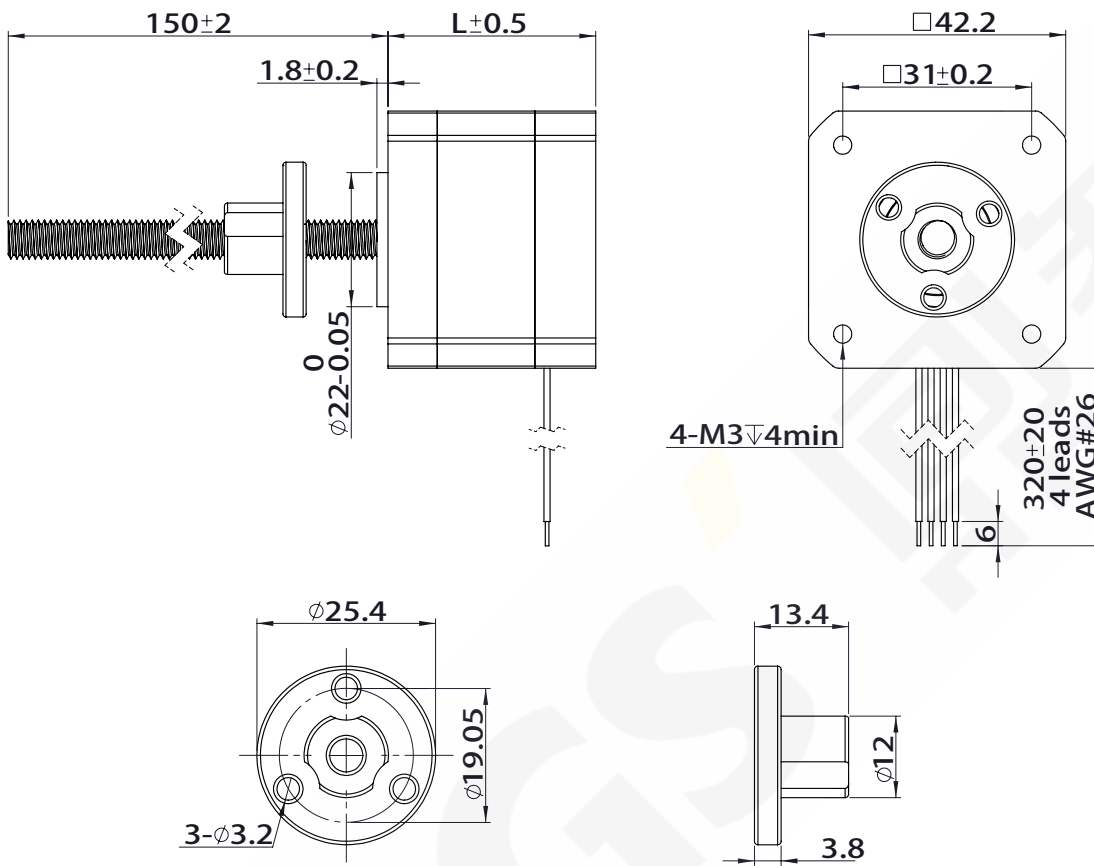

**Non-Captive Actuator**

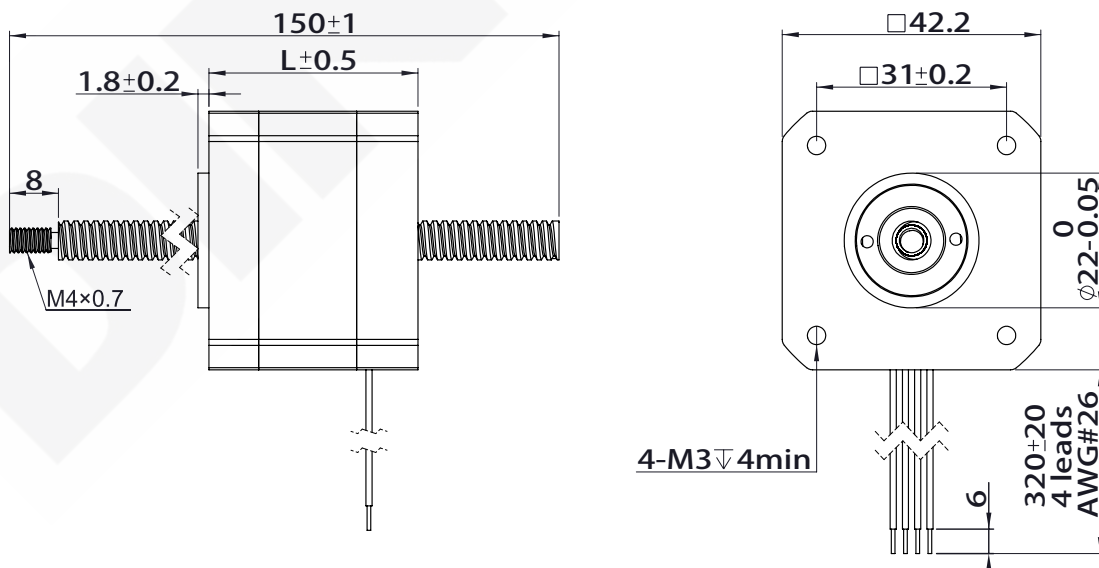

**NOTE:** All drawings are First Angle Projection – ISO Standard. [3D Models are available].

## Size 17 (42mm) Series

### Captive Actuator

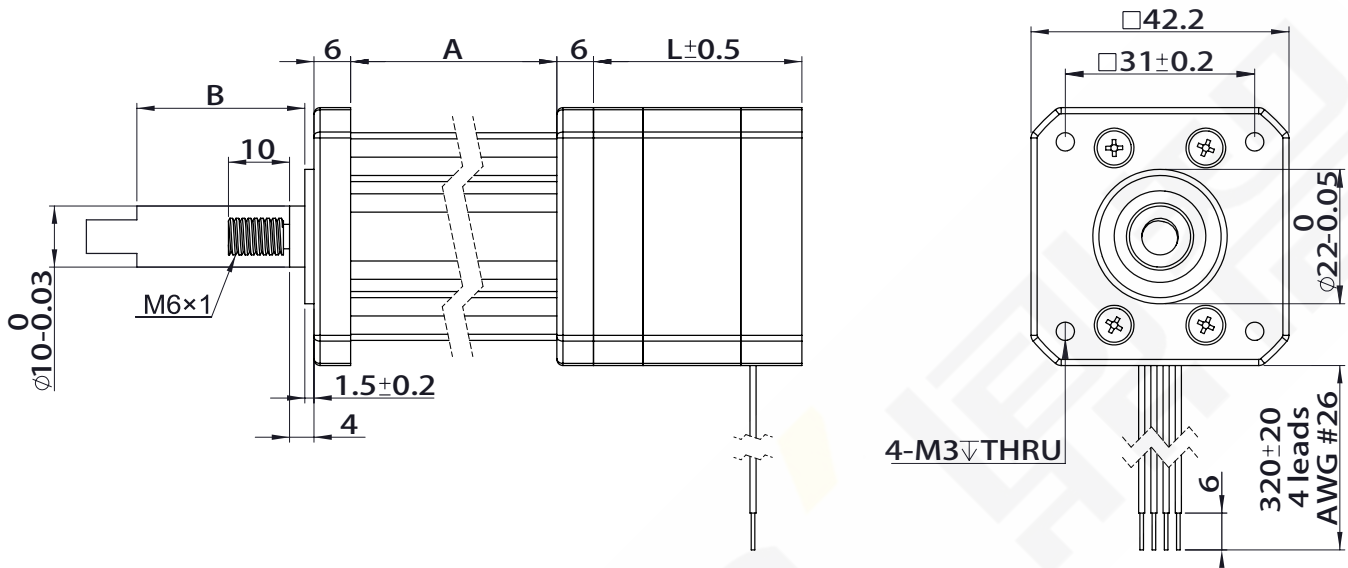

#### ● Stroke Specification

Stroke B inch (mm)	A (mm)	L (mm)	
0.50 (12.70)	35.70	Single Stack Motor 34.1mm	Double Stack Motor 48.1mm
0.75 (19.05)	42.05		
1.00 (25.40)	48.40		
1.25 (31.80)	54.80		
1.50 (38.10)	61.10		
2.00 (50.80)	73.80		
2.50 (63.50)	86.50		

**Kaptive Actuator**

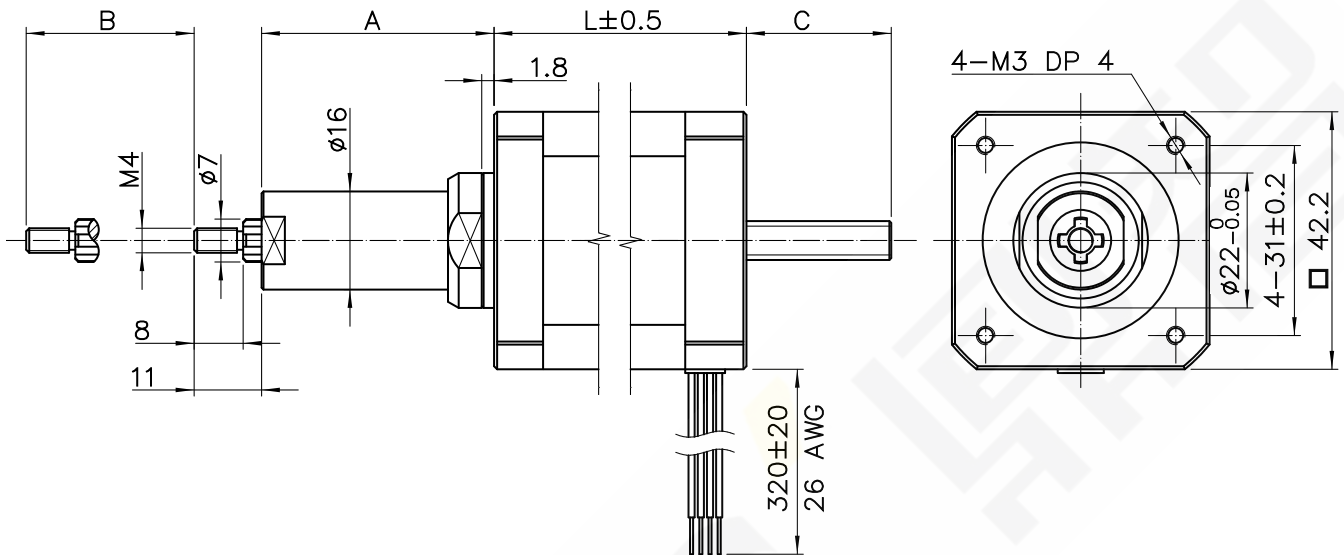

● **Stroke Specification**

Stroke B (mm)	A (mm)	C (mm)	
		L=34.1 (mm)	L=48.1 (mm)
12.70	18.50	4.10	0.00
19.05	24.85	10.45	5.45
25.40	31.20	16.80	11.80
31.75	37.55	23.15	18.15
38.10	43.90	29.50	24.50
50.80	56.60	42.20	37.20
63.50	69.30	54.90	49.90

**NOTE:** All drawings are First Angle Projection – ISO Standard. [3D Models are available].



## Size 17 (42mm) Series

### Size 17 (42mm) Performance Curves

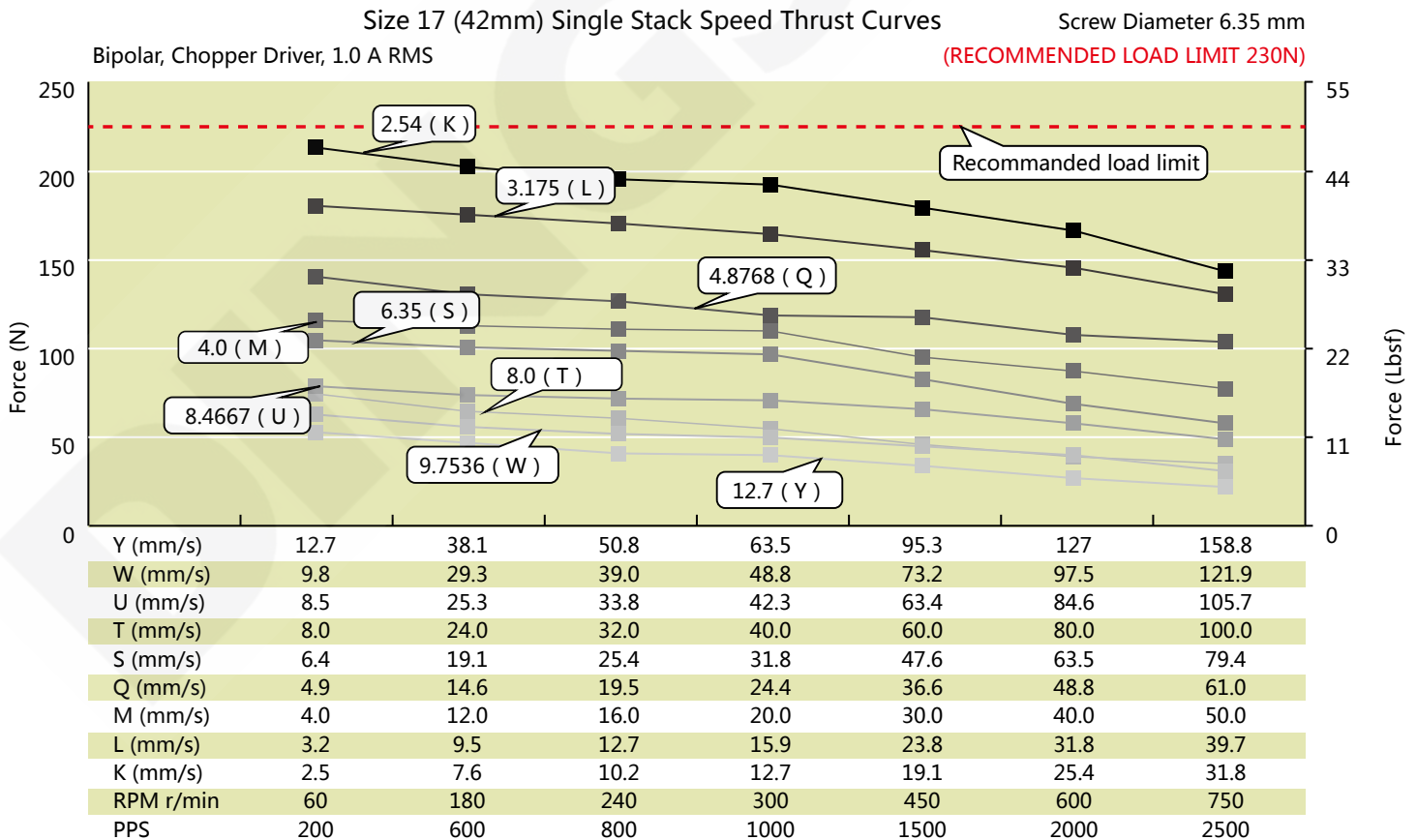
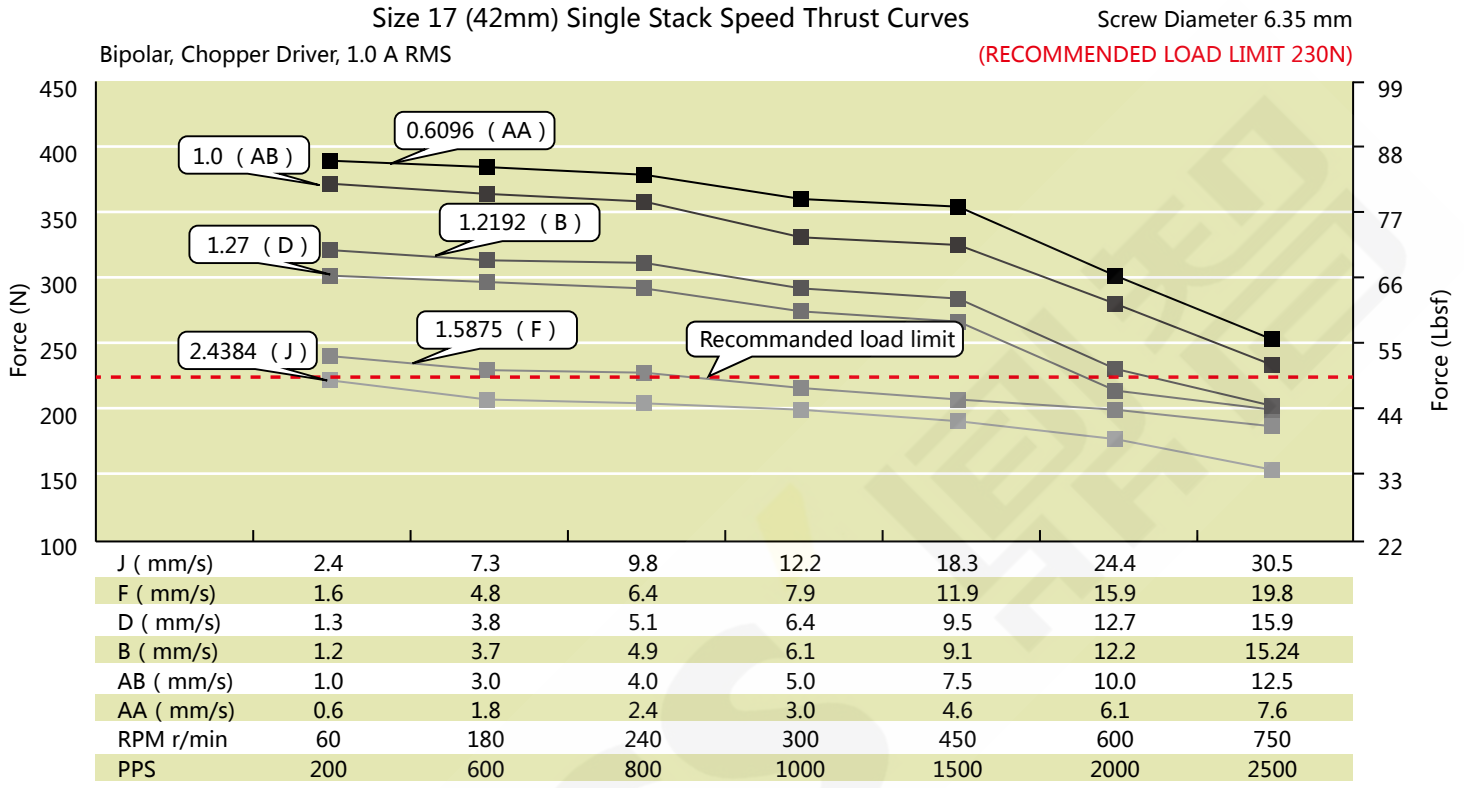

#### TEST CONDITION:

Testing Voltage: 24VDC, Driver Model: DS-2422-001, at rated current (rms) pull-in thrust. Motor's thrust will be changed with different voltage and driver. 50% thrust margin is recommended.

## Size 17 (42mm) Series

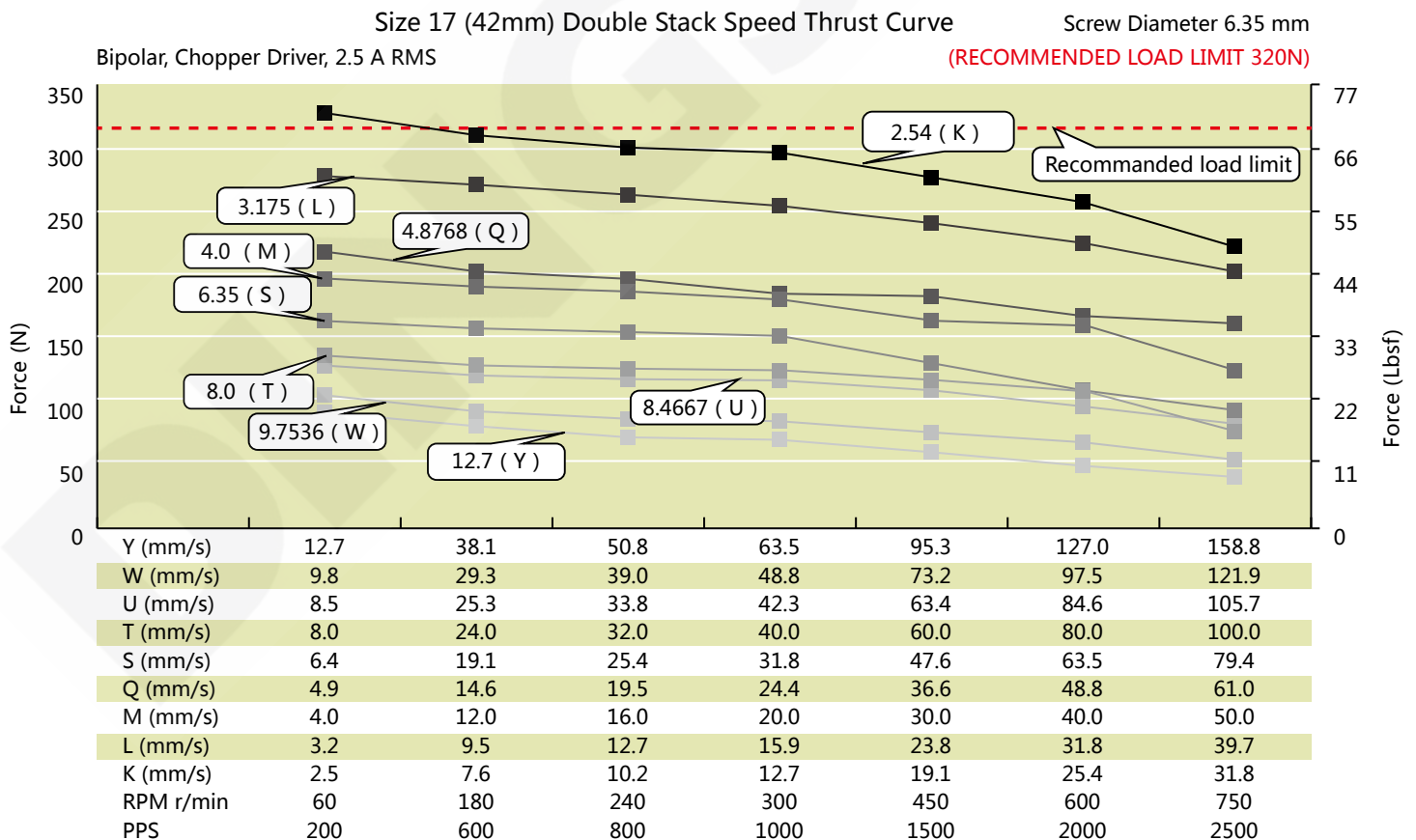
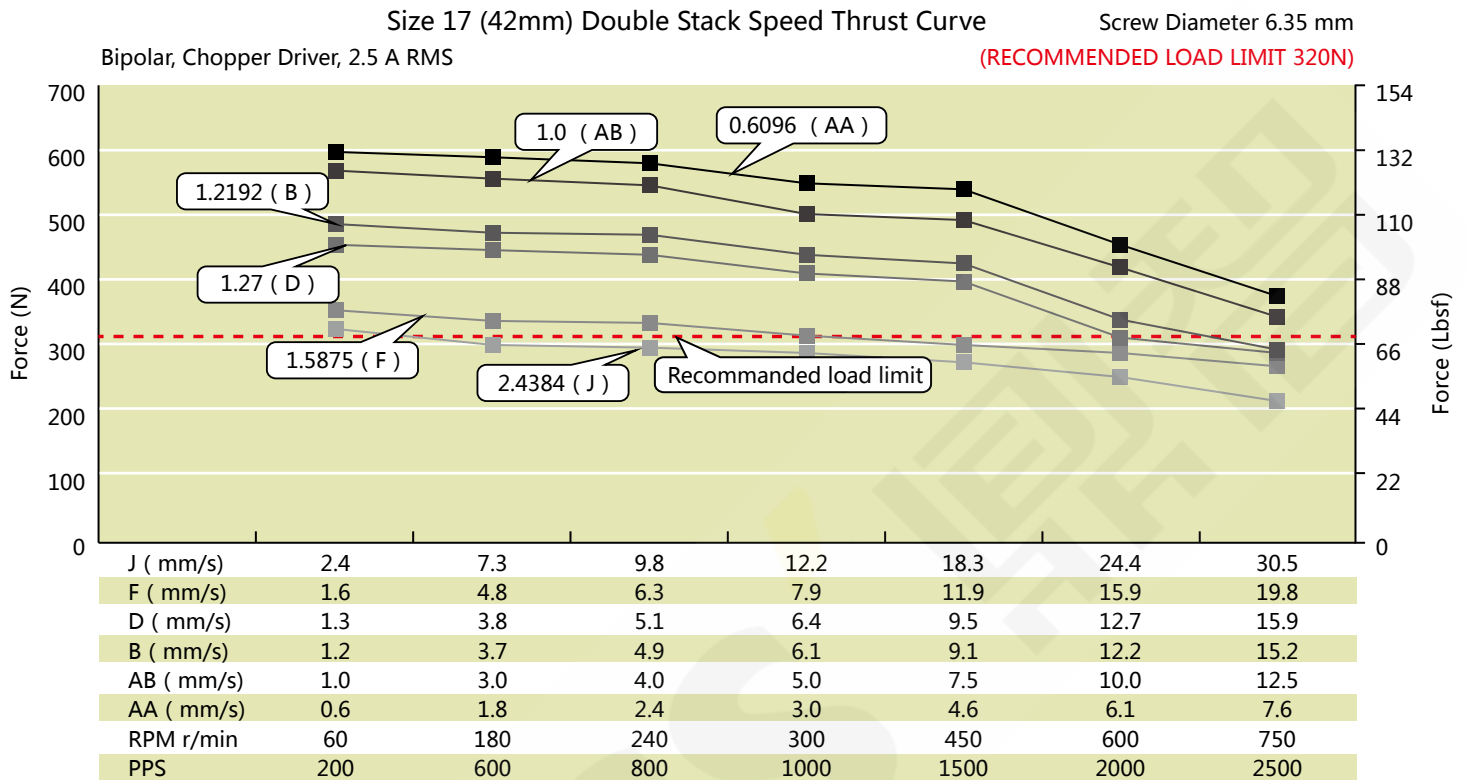

**TEST CONDITION:**

Testing Voltage: 24VDC, Driver Model: DS-2422-001, at rated current (rms) pull-in thrust. Motor's thrust will be changed with different voltage and driver. 50% thrust margin is recommended.

## Size 23 (57mm) Series

[BACK TO](#)

The size 23 hybrid precision linear actuator is with high performance and longer working cycle, which could be applied with high request of force, it is capable of 910N.

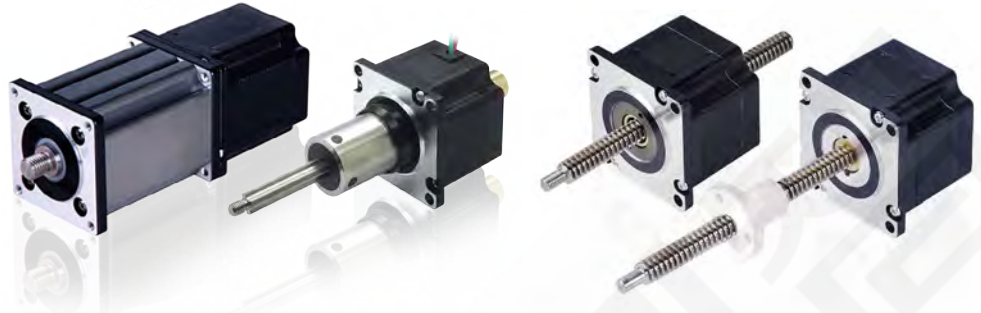

### Motor Characteristics

Motor	Voltage (V)	Current (A)	Resistance ( $\Omega$ )	Inductance (mH)	Weight (g)	Lead Wire No.	Motor Length (mm)
23-2110	6.4	1.0	6.4	16.4	585	4	45
23-2120	3.2	2.0	1.75	4.1	585	4	45
23-2130	2.1	3.0	0.8	1.7	585	4	45
23-2210	10.8	1.0	11.5	32.0	880	4	65
23-2225	4.2	2.5	2.0	5.2	880	4	65
23-2240	2.4	4.0	0.7	2.0	880	4	65

### Available Lead Screw and Travel per Step

Screw Dia. (inch)	Screw Dia. (mm)	Lead (inch)	Lead (mm)	Lead Code	Travel Per Step @ 1.8 deg (mm)*	Travel Per Step @ 0.9 deg (mm)*
0.315	10.000	0.079	2.0000	MG	0.0100	0.0050
0.375	9.525	0.025	0.6350	A	0.0030	0.0016
0.375	9.525	0.050	1.2700	D	0.0060	0.0032
0.375	9.525	0.062	1.5875	F	0.0080	0.0040
0.375	9.525	0.083	2.1167	H	0.0110	0.0053
0.375	9.525	0.100	2.5400	K	0.0120	0.0064
0.375	9.525	0.125	3.1750	L	0.0150	0.0079
0.375	9.525	0.167	4.2333	P	0.0210	0.0106
0.375	9.525	0.200	5.0800	R	0.0250	0.0127
0.375	9.525	0.250	6.3500	S	0.0310	0.0159
0.375	9.525	0.375	9.5250	V	0.0470	0.0238
0.375	9.525	0.384	9.7536	W	0.0480	0.0244
0.375	9.525	0.400	10.1600	X	0.0510	0.0254
0.375	9.525	0.500	12.7000	Y	0.0630	0.0318
0.375	9.525	1.000	25.4000	Z	0.1270	0.0635

Value truncated

**Size 23 (57mm) Series**

**Dimensional Drawings**  
**External Actuator**

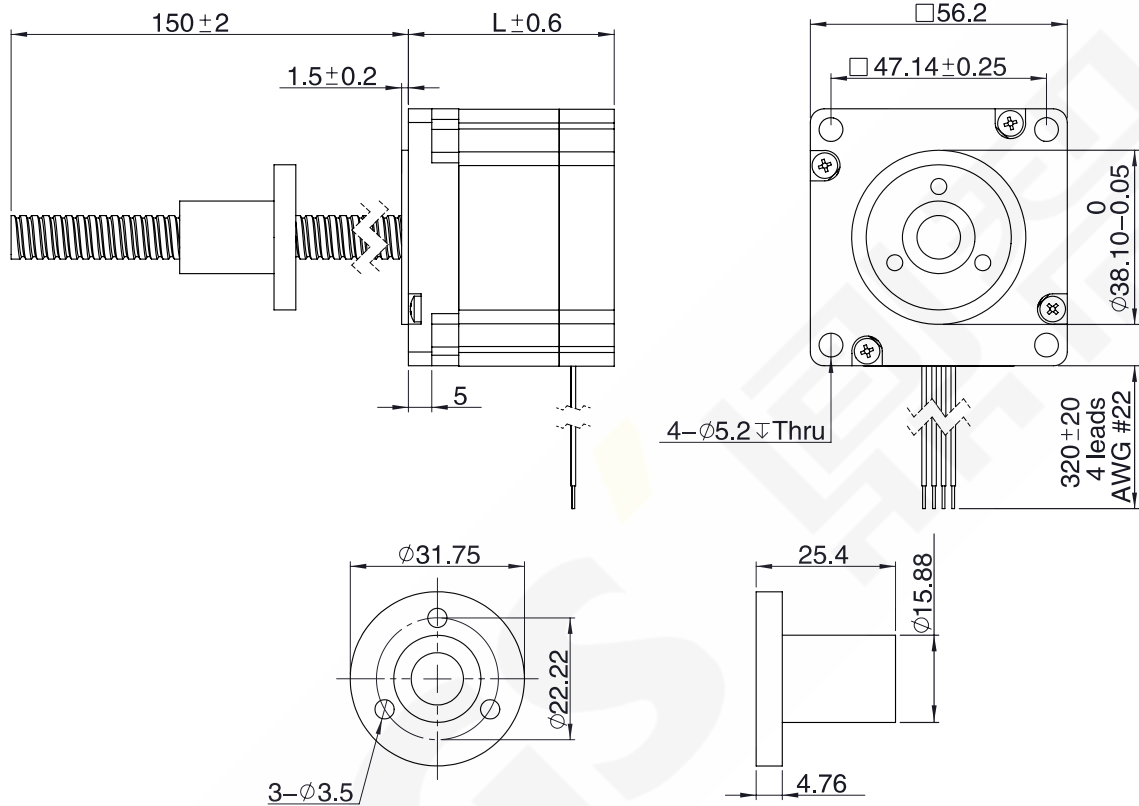

**Non-Captive Actuator**

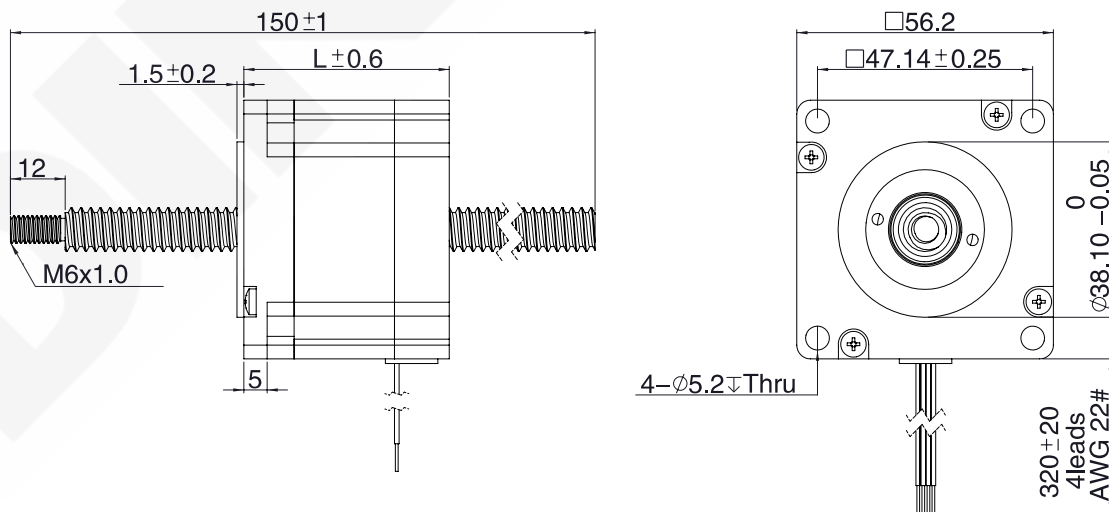

**NOTE:** All drawings are First Angle Projection - ISO Standard. [3D Models are available].



## Size 23 (57mm) Series

### Captive Actuator

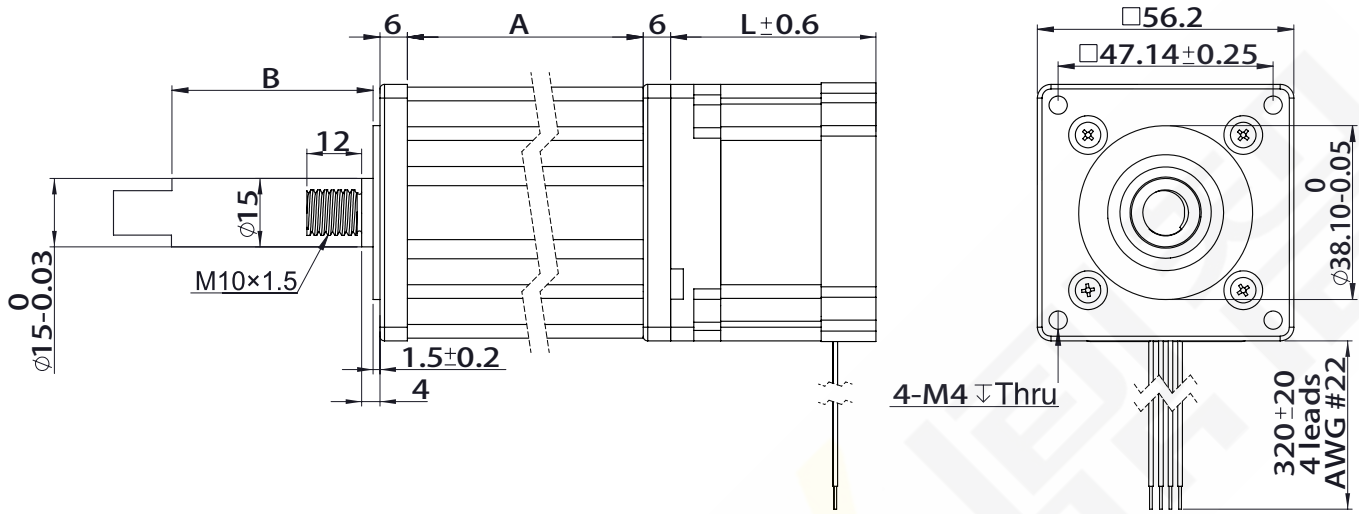

#### ● Stroke Specification

Stroke B inch (mm)		A (mm)	L (mm)	
0.50	(12.70)	45.70	Single Stack Motor 45mm	Double Stack Motor 65mm
0.75	(19.05)	52.05		
1.00	(25.40)	58.40		
1.25	(31.80)	64.80		
1.50	(38.10)	71.10		
2.00	(50.80)	83.80		
2.50	(63.50)	96.50		

**Kaptive Actuator**

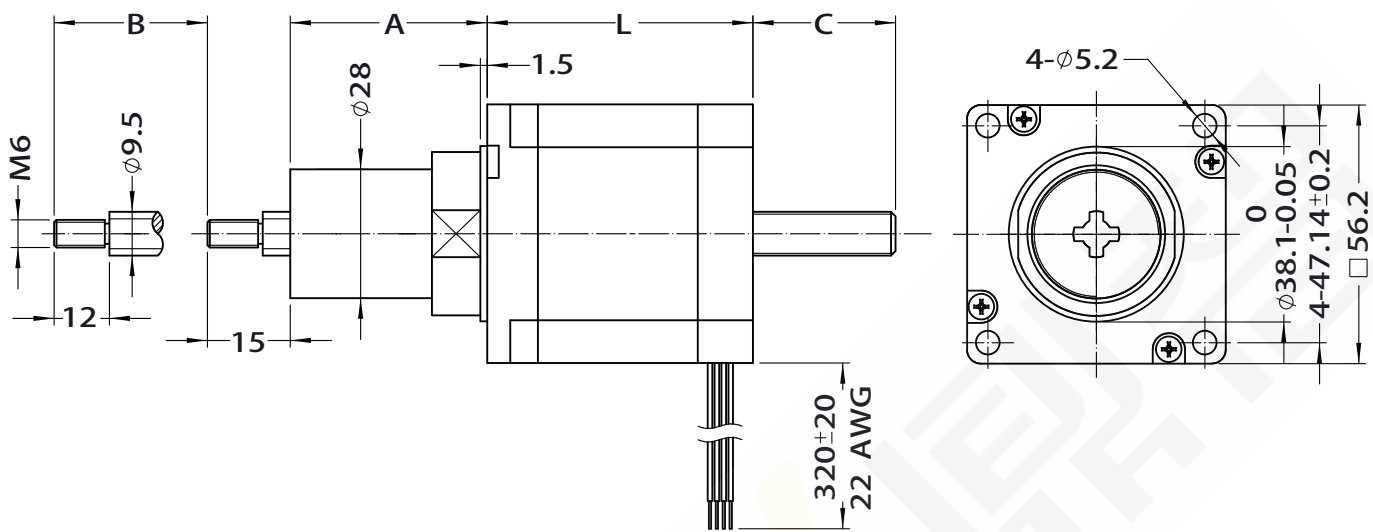

● **Stroke Specification**

Stroke B (mm)	A (mm)	C (mm)	
		L=45 (mm)	L=65 (mm)
12.70	24.20	5.80	0.00
19.05	30.55	12.15	2.15
25.40	36.90	18.50	8.50
31.75	43.25	24.85	14.85
38.10	49.60	31.20	21.20
50.80	62.30	43.90	33.90
63.50	75.00	56.60	46.60

# Size 23 (57mm) Series

## Size 23 (57mm) Performance Curves

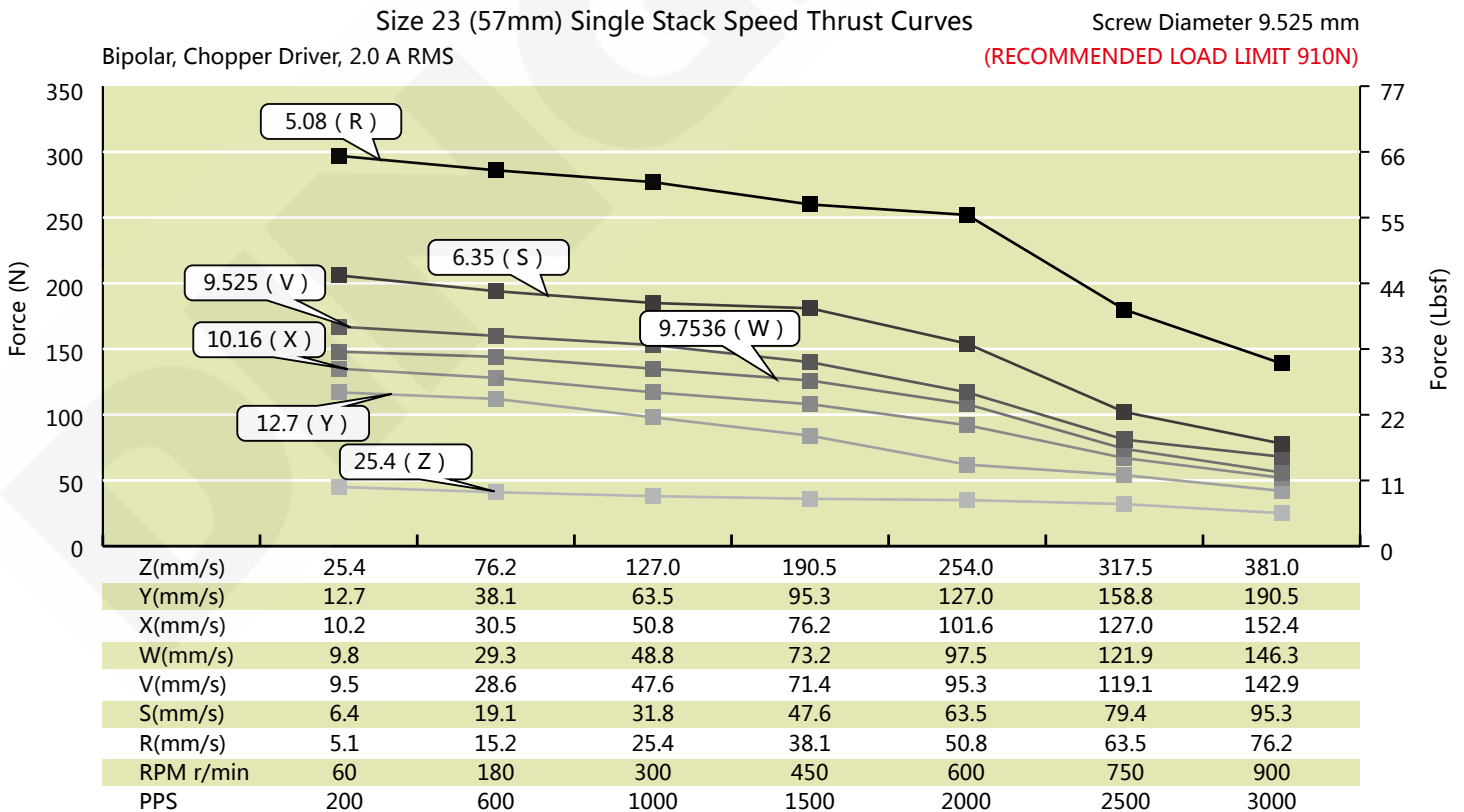
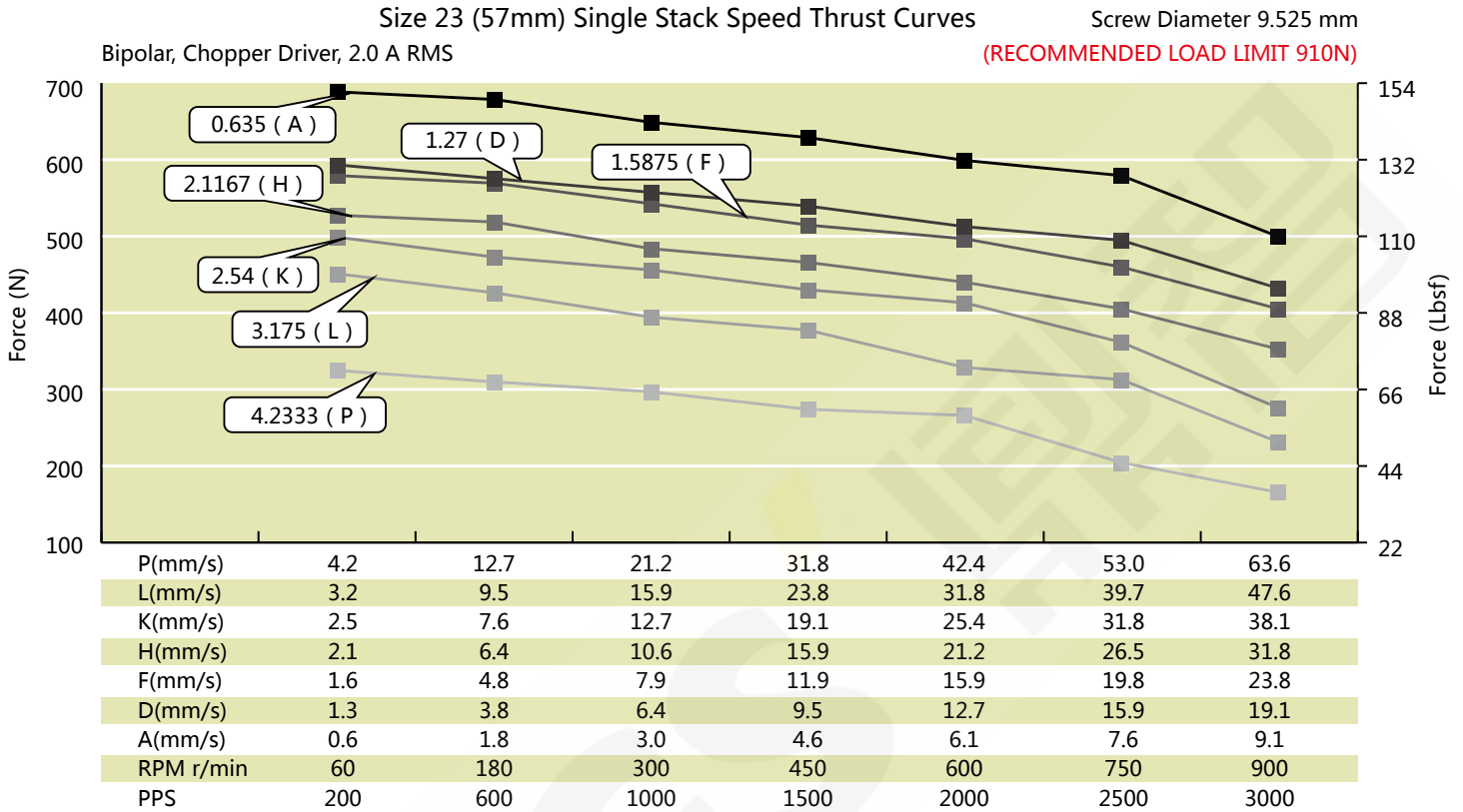

**TEST CONDITION:**

Testing Voltage: 40VDC, Driver Model: DS-5045-003, at rated current (rms) pull-in thrust. Motor's thrust will be changed with different voltage and driver. 50% thrust margin is recommended.

## Size 23 (57mm) Series

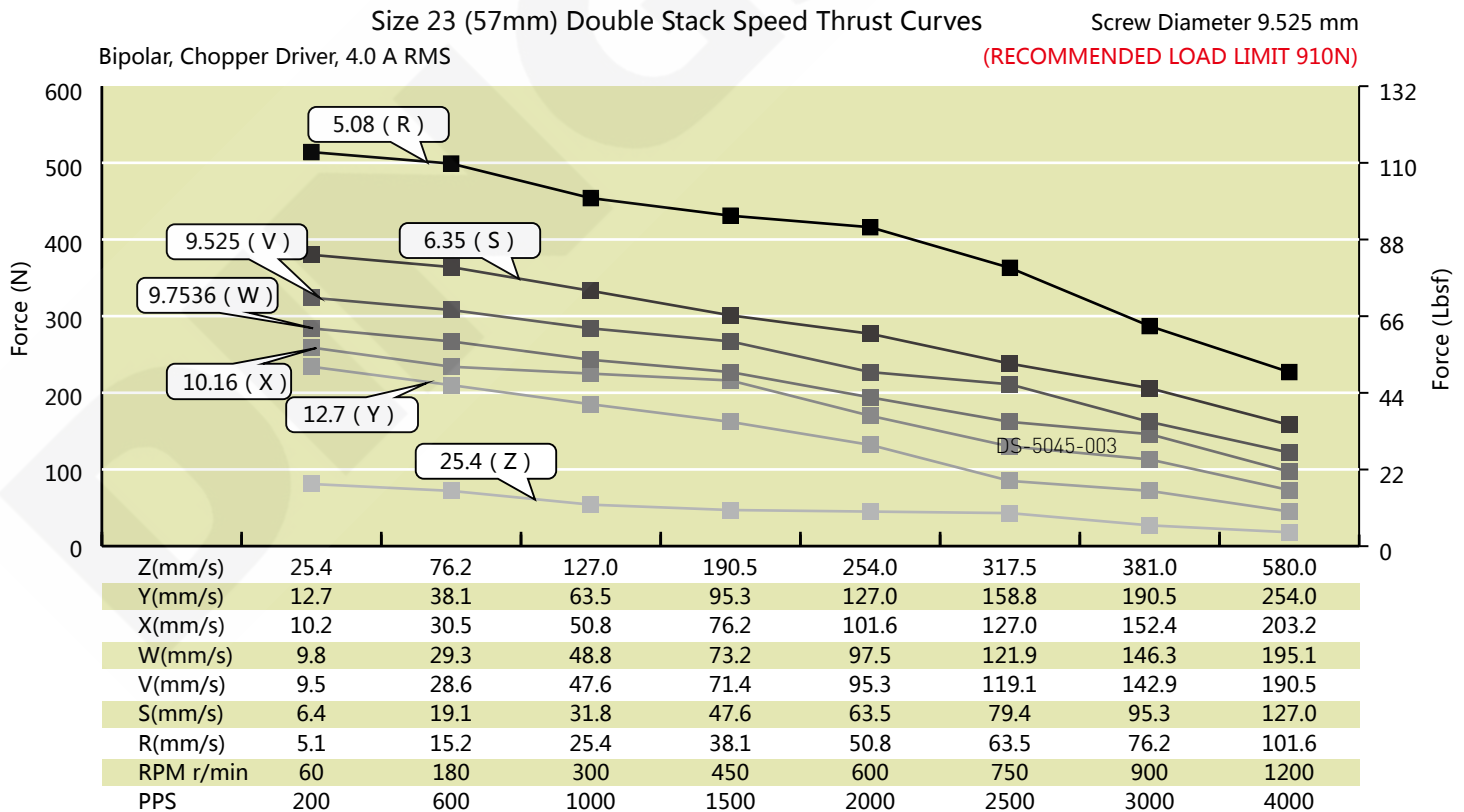
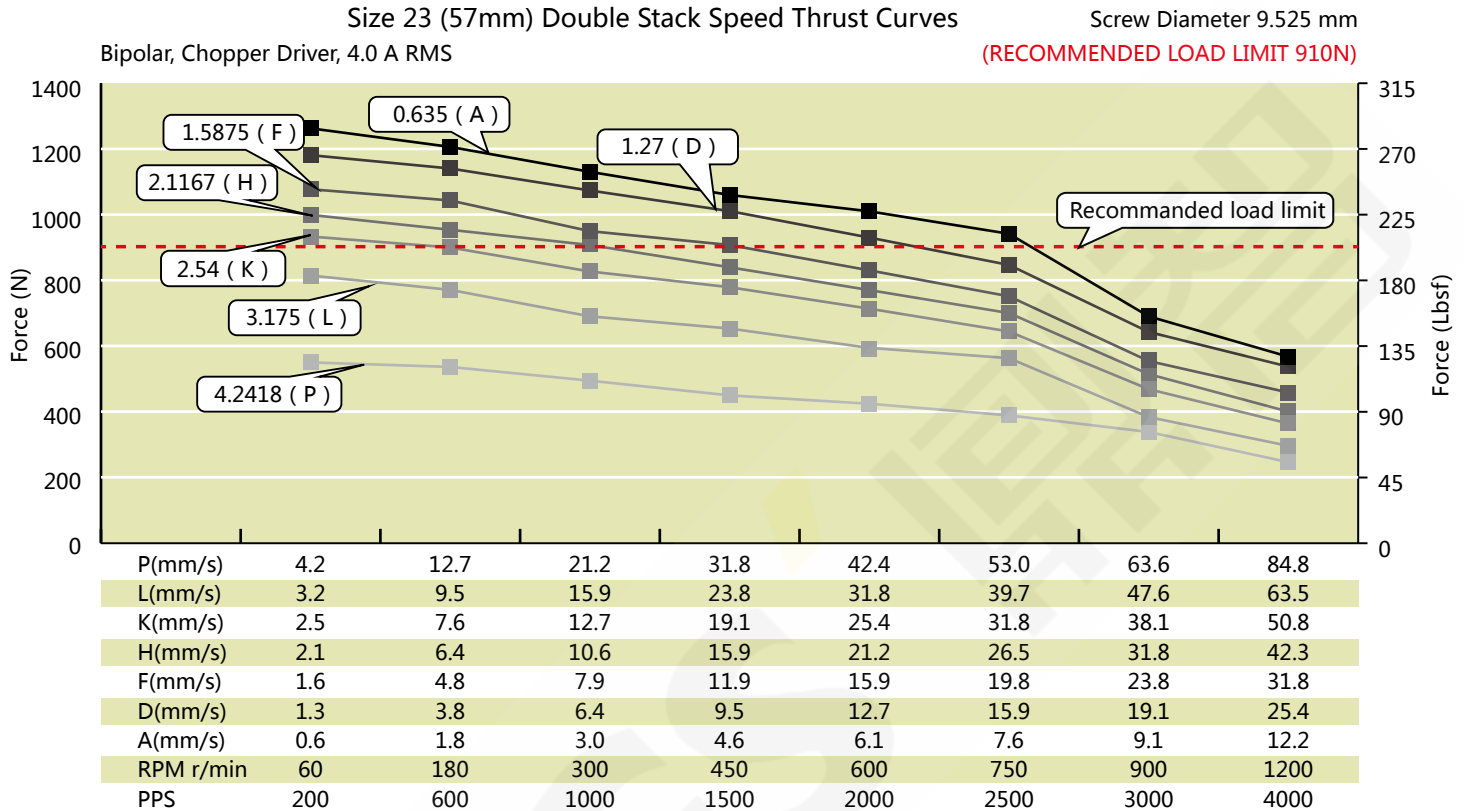

**TEST CONDITION:**

Testing Voltage: 40VDC, Driver Model: DS-5045-003, at rated current (rms) pull-in thrust. Motor's thrust will be changed with different voltage and driver. 50% thrust margin is recommended.



## Size 34 (86mm) Series

[BACK TO](#)

The size 34 hybrid precision linear actuator is in big size, high power, with best performance, which capable of 2270N of continuous thrust.

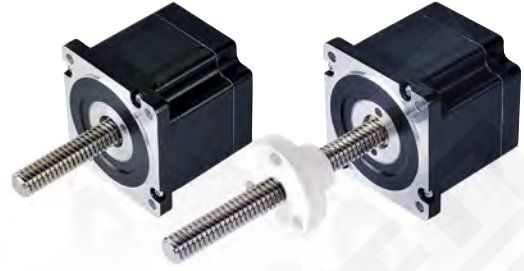

### Motor Characteristics

Motor	Voltage (V)	Current (A)	Resistance (Ω)	Inductance (mH)	Weight (g)	Lead Wire No.	Motor Length (mm)
34-2113	12.0	1.3	9.2	71.0	2370	4	76
34-2130	5.7	3.0	1.9	15.0	2370	4	76
34-2155	2.85	5.5	0.52	4.5	2370	4	76

### Available Lead Screw and Travel per Step

Screw Dia. (inch)	Screw Dia. (mm)	Lead (inch)	Lead (mm)	Lead Code	Travel Per Step @ 1.8 deg (mm)*	Travel Per Step @ 0.9 deg (mm)*
0.625	15.875	0.100	2.540	K	0.0127	0.0051
0.625	15.875	0.125	3.175	L	0.0159	0.0064
0.625	15.875	0.200	5.080	R	0.0254	0.0102
0.625	15.875	0.250	6.350	S	0.0318	0.0127
0.625	15.875	0.500	12.700	Y	0.0635	0.0318
0.625	15.875	1.000	25.400	Z	0.1270	0.0508

Value truncated

### Dimensional Drawings External Actuator

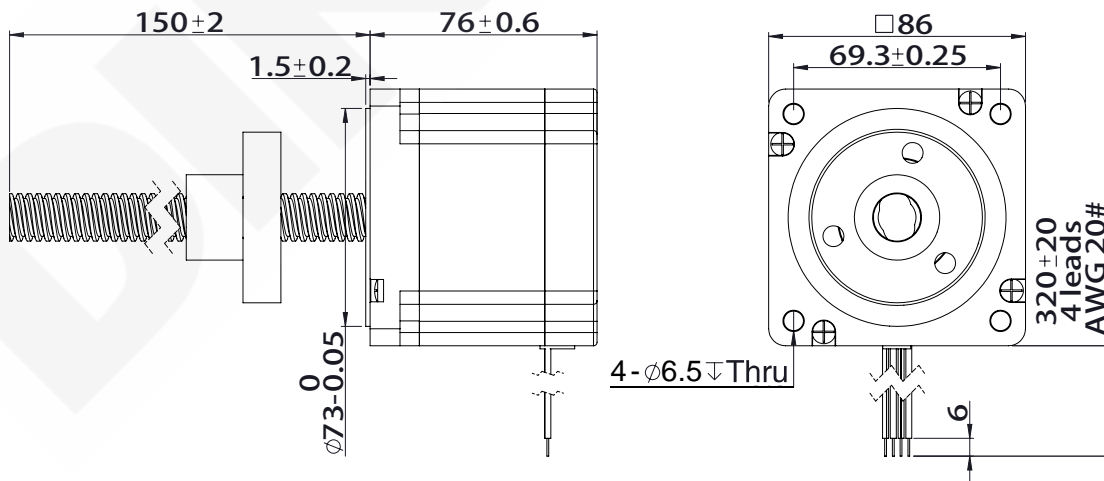

**Size 34 (86mm) Series**

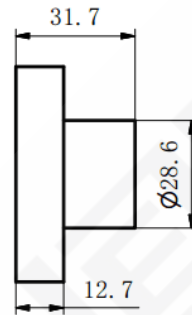
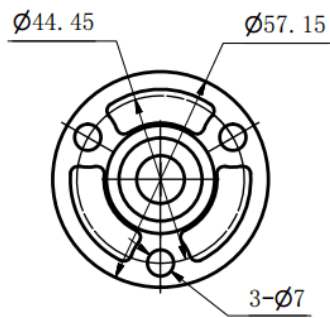

**Non-Captive Actuator**

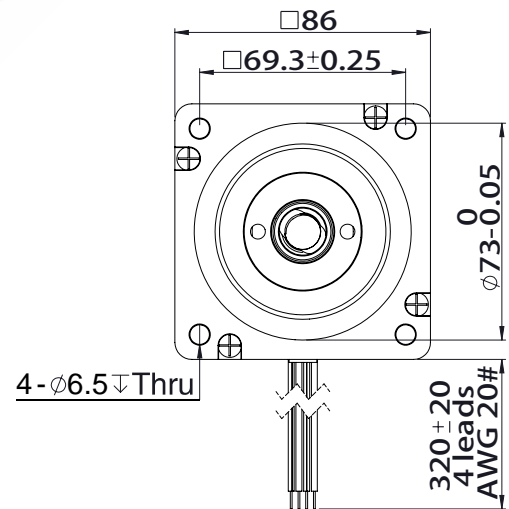
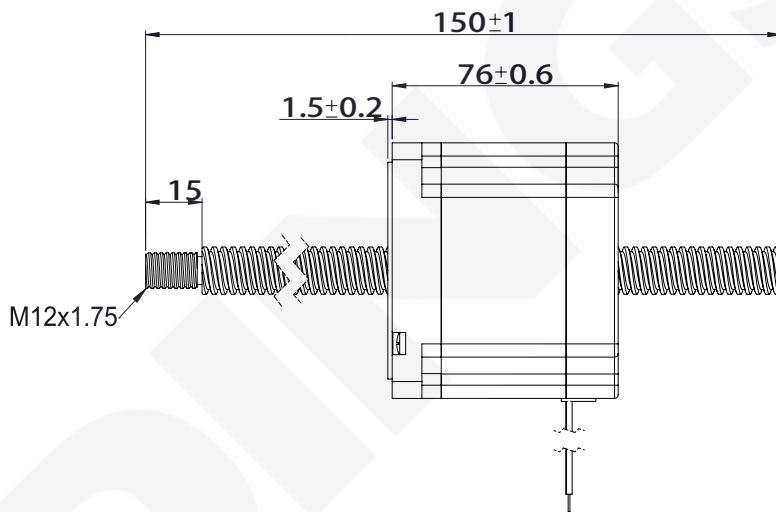

**NOTE:** All drawings are First Angle Projection – ISO Standard. [3D Models are available].

## Size 34 (86mm) Series

### Size 34 (86mm) Performance Curves

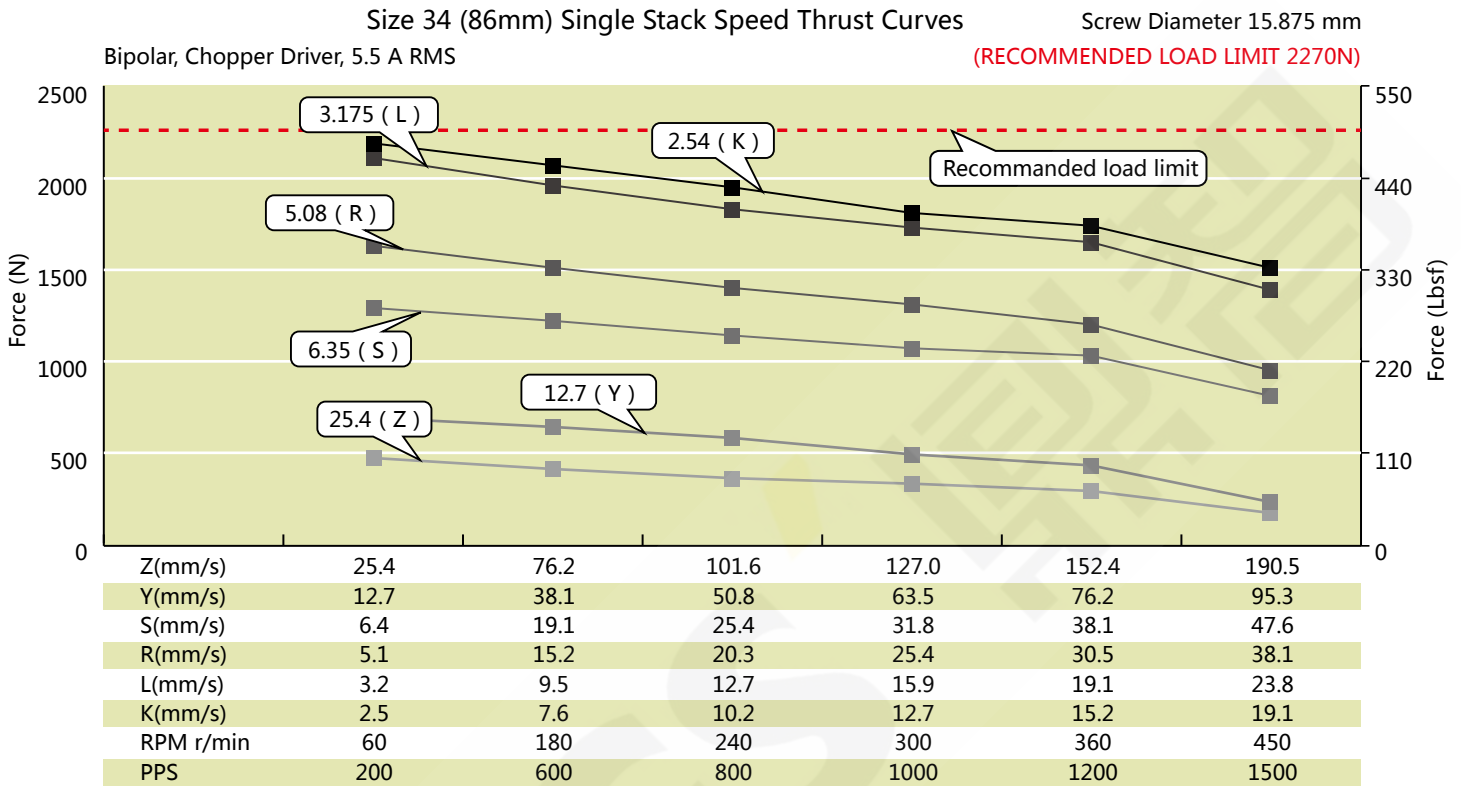

**TEST CONDITION:**

A-40 Testing Voltage: 40VDC, Driver Model: DS-2MSD8078-2, at rated current (rms) pull-in thrust. Motor's thrust will be changed with different voltage and driver. 50% thrust margin is recommended.

■ **Screw End Machining**

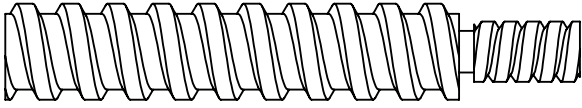
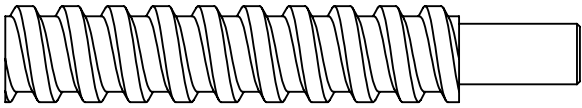
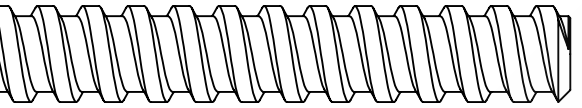
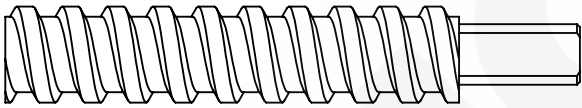
	<p>Threaded End</p>	<p>The screw end machining was machined depended on screw diameter. Please contact DINGS' or your local DINGS' representative for detailed screw machining specifications.</p>
	<p>Smooth End</p>	
	<p>None</p>	
	<p>Customize</p>	



## Accessories and Options

### ■ Anti-Backlash Nut

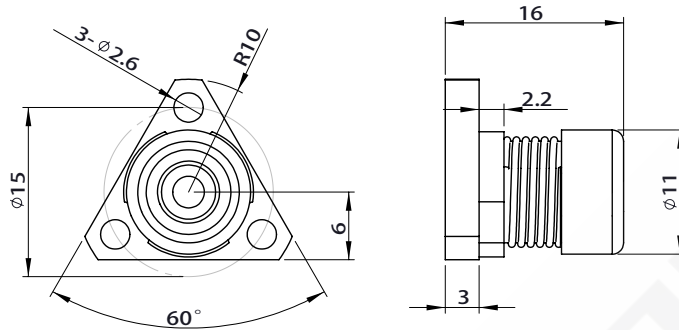

Size 8 (20mm) and Size 11 (28mm) anti-backlash nut

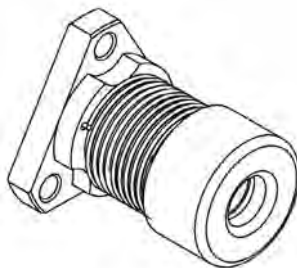
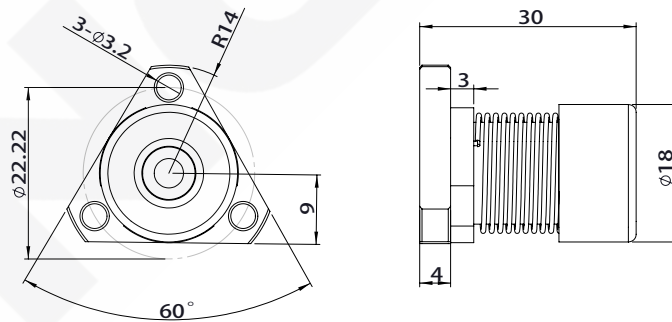

Size 14 (35mm) and Size 17 (42mm) anti-backlash nut

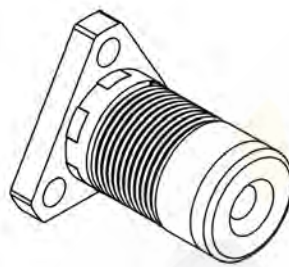
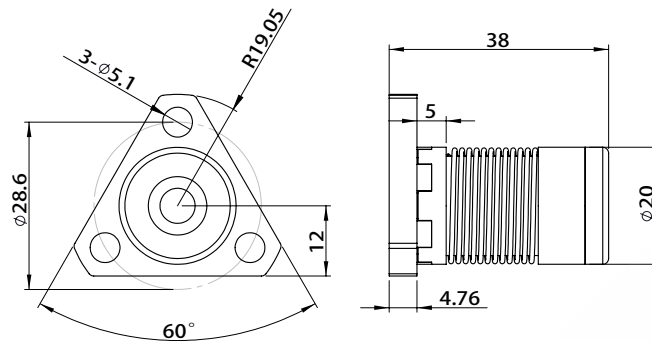

Size 23 (57mm) anti-backlash nut

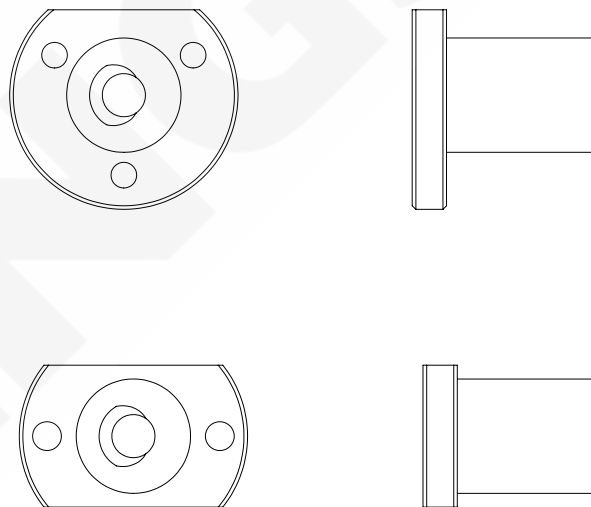

Customized Nut

**FOR MORE INFORMATION, CONTACT YOUR LOCAL  
DINGS' REPRESENTATIVE  
(REFERENCE CATALOGUE BACK COVER)**

## Accessories and Options

### Encoder

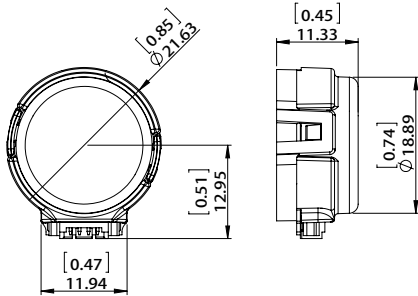

EK1 Encoder – single ended output

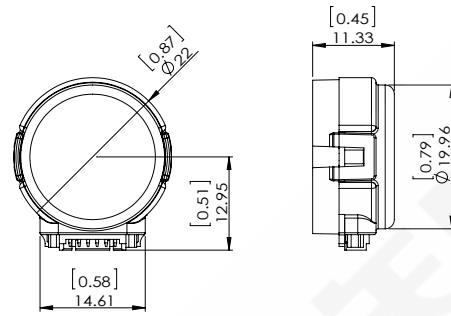

EK1 Encoder – differential output

#### EK1 Encoder (Used for Size 8, 11, 14, 17 Motor)\* No index

Resolution	100	108	120	125	128	200	250	256	300	360	400	500
Single ended output	0	1	2	3	4	5	6	7	8	9	10	11
Differential output	A	B	C	D	E	F	G	H	I	J	K	L

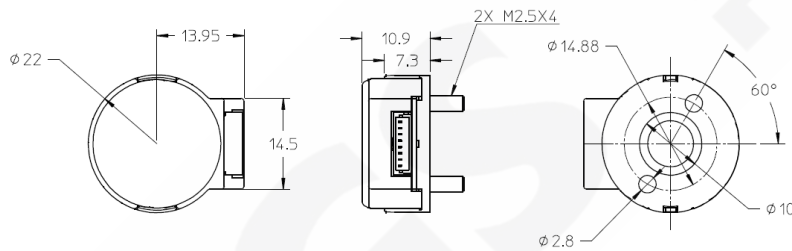

EK1 Encoder – differential output

#### EK5 Encoder (Used for Size 8, 11, 14, 17 Motor)\* With index

Resolution	360	500	512	1000	1024	2000	2048
Single ended output	0	1	2	3	4	5	6
Differential output	A	B	C	D	E	F	G

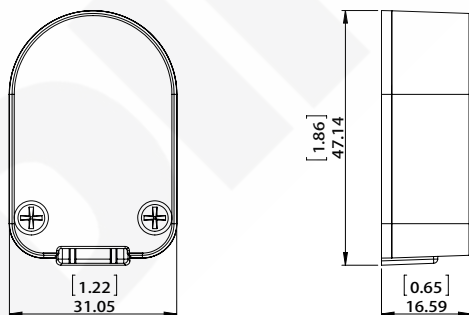

EK2 Encoder – single ended output

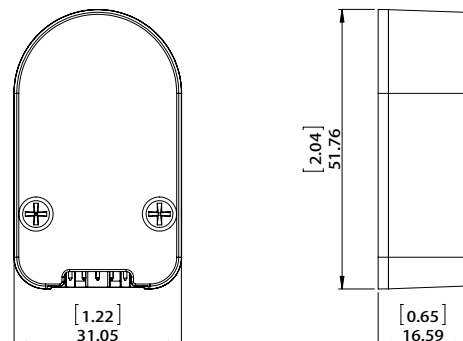

EK2 Encoder – differential output

#### EK2 Encoder (Used for Size 14, 17, 23 Motor)

Resolution	50	100	192	200	250	256	360	400	500	720	900	1000	1250	2000	2500	4000	5000
Single ended output	0	1	2	3	4	5	6	7	8	9	10	11	12				
Differential output	A	B	C	D	E	F	G	H	I	J	K	L	M	N	O	P	Q

## Accessories and Options

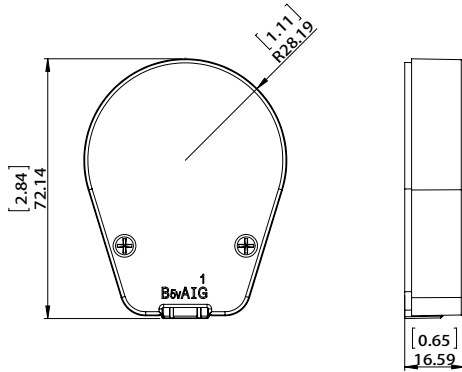

EK3 Encoder – single ended output

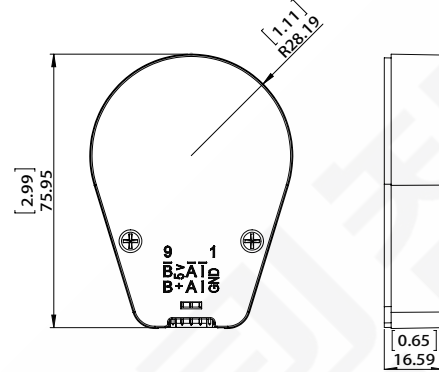

EK3 Encoder – differential output

● **EK3 Encoder (Used for Size 23, 34 Motor)**

Resolution	64	100	200	500	1000	1800	2000	2500	3600	4000	5000	7200	8000	10000
Single ended output	0	1	2	3	4	5	6	7	8					
Differential output		A	B	C	D	E	F	G	H	I	J	K	L	M

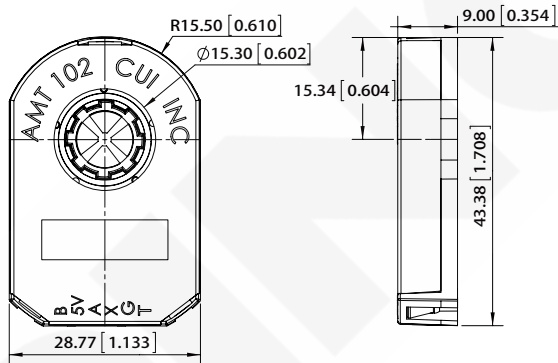

EK4 Encoder-single ended output (size14,17)

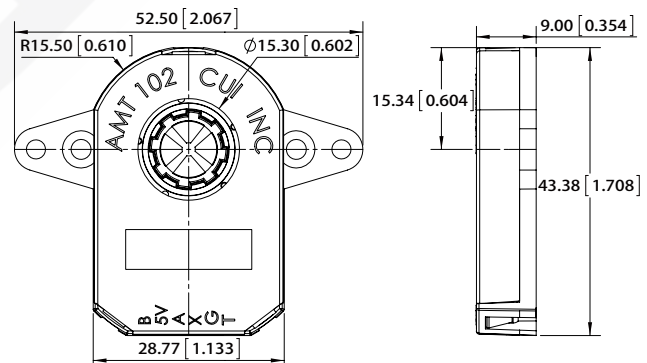

EK4 Encoder-single ended output (size23)

● **EK4 Encoder (Used for Size 14, 17, 23 Motor)**

Resolution	48	96	100	125	192	200	250	256	384	400	500	512	800	1000	1024	2048
Single ended output	0	1	2	3	4	5	6	7	8	9	10	11	12	13	14	15
Differential output	-	-	-	-	-	-	-	-	-	-	-	-	-	-	-	-



## Accessories and Options

### RMB20SC Encoder

Closed loop stepping motor system which perfectly resolves the problems of current open loop control stepping motor system such as step out and positioning completion check.

RMB20SC - Synchro serial interface (SSI) with 320 to 8,192 positions per revolution

1. 20 mm diameter circular module
2. 5 V power supply
3. High speed operation to 60,000 rpm
4. Absolute - to 13 bit resolution (8,192 counts per revolution)
5. Industry standard absolute, incremental, analogue and linear output formats
6. Accuracy to  $\pm 0.5^\circ$
7. RoHS compliant (lead free)

### RMB20 installation drawing

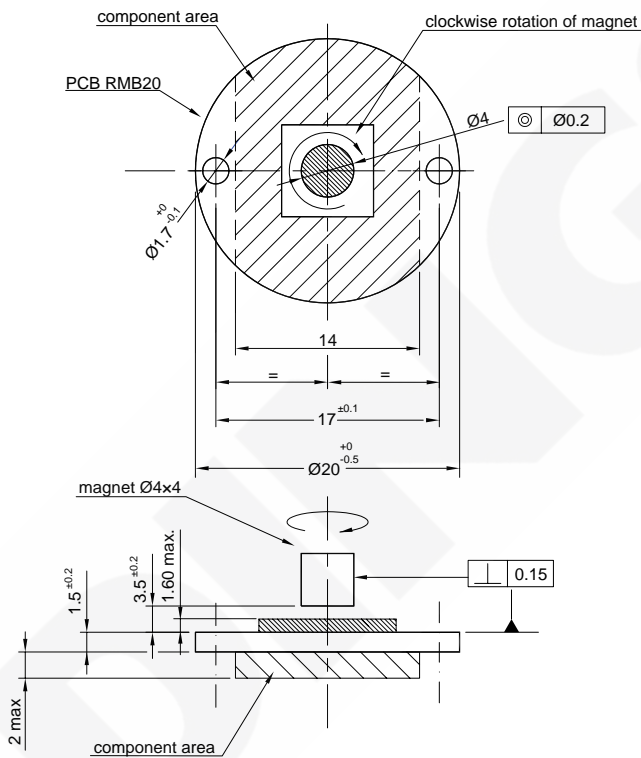

Clockwise (CW) rotation of magnet

**NOTE:** For the accuracy specified the center line of the magnet needs to be square to the chip within  $2^\circ$  and aligned within the center of the board  $\pm 0.1$  mm (mid point between the 2 mounting holes).

**RMB20SC – Absolute binary synchro-serial interface (SSI)**

**Serial encoded absolute position measurement**

Output code: Natural binary  
 Power supply:  $V_{dd} = 5V \pm 5\%$   
 Power consumption: 23 mA for 9 bit resolution  
 35 mA for all other resolutions  
 Repeatability:  $\leq 0.07^\circ$   
 Data output: Serial data (RS422)  
 Data input: Clock (RS422)  
 Temperature:  $-40^\circ\text{C}$  to  $+125^\circ\text{C}$   
 Operating and storage

**Timing diagram**

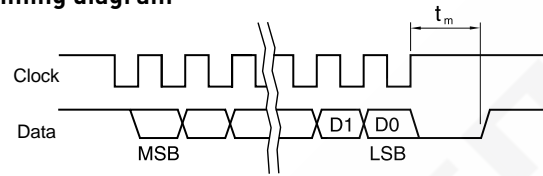

Clock  $\leq 900\text{ kHz}$ :  $16\ \mu\text{s} \leq t_m \leq 22\ \mu\text{s}$   
 (for 9 bit resolution)  
 Clock  $\leq 4\text{ MHz}$ :  $12.5\ \mu\text{s} \leq t_m \leq 20.5\ \mu\text{s}$   
 (for all other resolutions)  
 Position increases for clockwise rotation of magnet.

Resolution options (positions per rev)	Maximum speed (rpm)	Accuracy*	Hysteresis
256, 320, 400, 500	30,000	$\pm 0.7^\circ$	0.18°
512	30,000	$\pm 0.7^\circ$	0.45°
800, 1,000, 1,024	20,000	$\pm 0.5^\circ$	0.18°
1,600, 2,000, 2,048	10,000	$\pm 0.5^\circ$	0.18°
4096	5,000	$\pm 0.5^\circ$	0.18°
8192	2,500	$\pm 0.5^\circ$	0.18°

\* Worst case within operational parameters including magnet position and temperature.

**Recommended signal termination For data output lines only**

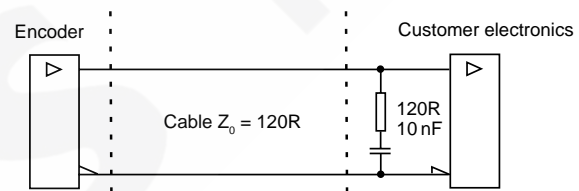

**Connections**

**RMB20SC - 9 bit resolution only**

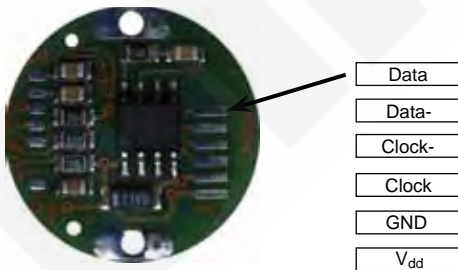

**RMB20SC - all other resolutions**

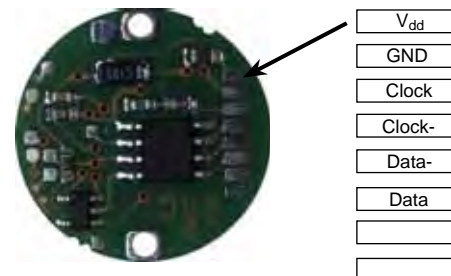

## Accessories and Options

### RMB28SC Encoder

The RMB28 encoder module is designed for direct integration to high volume OEM applications. The low cost 28 mm square PCB can also be provided with a connector

RMB28SC - Synchro serial interface (SSI) with 320 to 8,192 positions per revolution

1. Low cost for OEM integration
2. 24 V and 5 V power supply versions
3. High speed operation to 60,000 rpm
4. Absolute - to 13 bit resolution(8,192 counts per revolution)
5. Industry standard absolute,incremental, analogue,commutation and linear voltage output formats
6. Accuracy to  $\pm 0.5^\circ$
7. RoHS compliant (lead free)

### RMB28 installation drawing

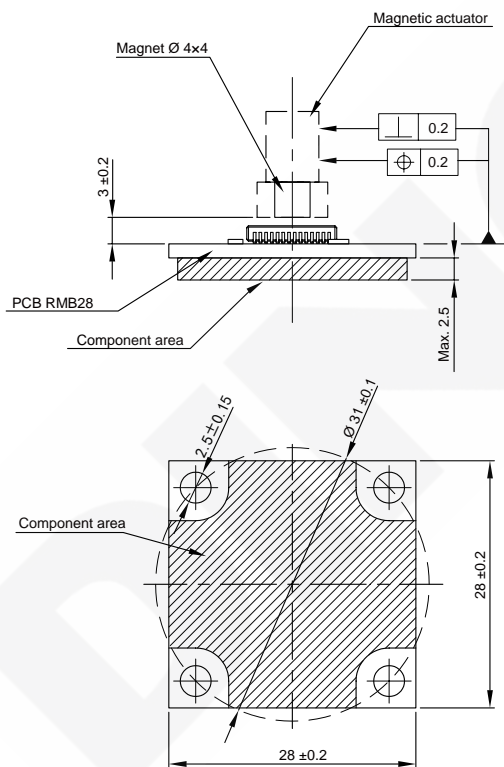

Clockwise (CW) rotation of magnet

### RMB28SC – Absolute binary synchro-serial interface (SSI)

#### Serial encoded absolute position measurement

Power supply:  $V_{dd} = 5V \pm 5\%$   
 Power consumption: 13 mA for 8 bit resolution  
 35 mA for all other resolutions  
 SSI output code: Natural binary  
 Data output : Serial data (RS422)  
 Data input: Clock (RS422)  
 Temperature:  $-40\text{ }^{\circ}\text{C}$  to  $+125\text{ }^{\circ}\text{C}$   
 Operating and storage  
 Maximum speed: 60,000 rpm

#### Timing diagram

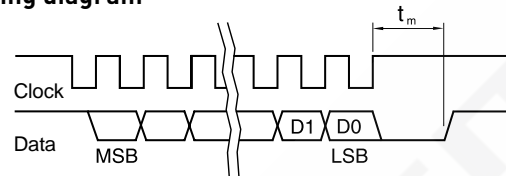

Clock  $\leq 900\text{ kHz}$ :  $16\text{ }\mu\text{s} \leq t_m \leq 22\text{ }\mu\text{s}$   
 (for 9 bit resolution)  
 Clock  $\leq 4\text{ MHz}$ :  $12.5\text{ }\mu\text{s} \leq t_m \leq 20.5\text{ }\mu\text{s}$   
 (for all other resolutions)  
 Position increases for clockwise rotation of magnet.

Resolution options (positions per rev)	Maximum speed (rpm)	Accuracy*	Hysteresis
128, 256	60,000	$\pm 0.7^{\circ}$	$0.45^{\circ}$
320, 400, 500, 512	30,000	$\pm 0.7^{\circ}$	$0.18^{\circ}$
800, 1,000, 1,024	20,000	$\pm 0.5^{\circ}$	$0.18^{\circ}$
1,600, 2,000, 2,048	10,000	$\pm 0.5^{\circ}$	$0.18^{\circ}$
4096	5,000	$\pm 0.5^{\circ}$	$0.18^{\circ}$
8192	2,500	$\pm 0.5^{\circ}$	$0.18^{\circ}$

\* Worst case within operational parameters including magnet position and temperature.

#### Recommended signal termination For data output lines only

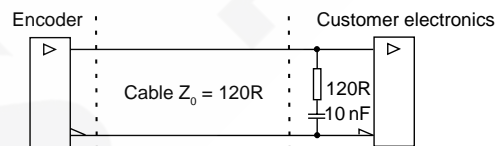

#### Connections

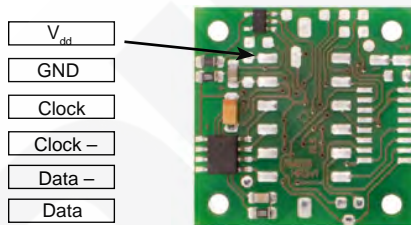

#### Connector type

Molex 43045-1219

#### Mating connector (Not provided)

Molex 43025-1200 (crimp terminal 43030-xxxx)





## Accessories and Options

### ■ Power OFF Brake

- 1.3 Nm (Available for size 23 motor)

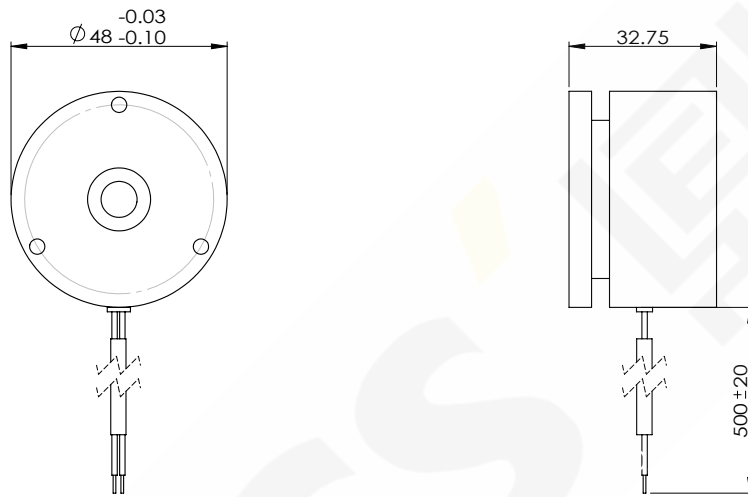

### ● Parameter

1. Rated voltage: DC24V +/- 10%
2. Resistance: 89.4 +/-5%
3. Power consumption: 6.5W
4. Hold torque: 1.3 Nm min
5. Insulation Class F
6. Rotor Inertia:  $1.47 \times 10^{-6} \text{kg.m}^2$
7. Insulation resistance: >100Mohm (DC500V)
8. Dielectrical Strength: AC1800V 1 sec
9. Retraction time: 50ms
10. Release time: 20ms
11. gyration gap:  $<1.5^\circ$
12. Emergency brake times: >200 times
13. Lifetime: >2,000,000 times
14. Noise Level: <60db

● **Power OFF Brake 0.32 Nm (Available for size 14, 17 motor)**

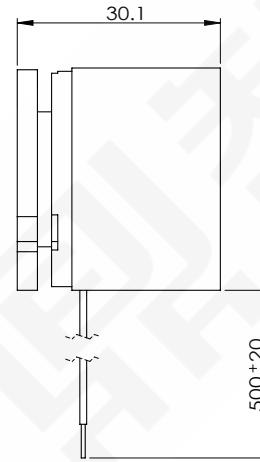
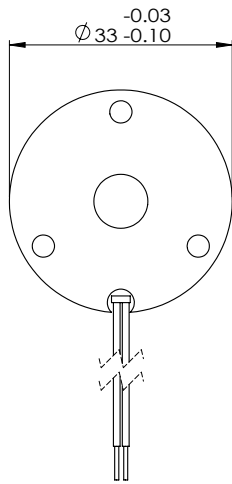

● **Parameter**

- |   |   |
|---|---|
| 1. Rated Voltage: DC24V +/- 10%                           | 8. Dielectrical Strength: AC1800V 1 sec |
| 2. Resistance: 94.4 +/-5%                                 | 9. Retraction time: 50ms                |
| 3. Power consumption: 6.1W                                | 10. Release time: 20ms                  |
| 4. Hold Torque: 0.32N.m                                   | 11. Gyration gap <1.5°                  |
| 5. Insulation Class F                                     | 12. Emergency brake times: >200 times   |
| 6. Rotor Inertia: 1.37x10 <sup>-7</sup> kg.m <sup>2</sup> | 13. Lifetime: >2,000,000 times          |
| 7. Insulation Resistance: >100Mohm (DC500V)               | 14. Noise Level: <60db                  |

■ **Manual Knob**

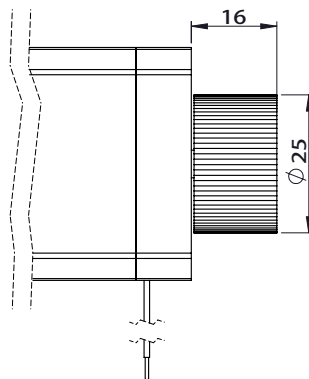

# Installation Guide

[BACK TO](#)

## NOTES:

### 1.Linear Stepper Motor + Linear Guide

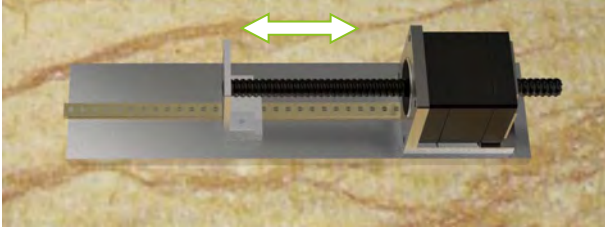

Non-captive Motor + Linear Guide

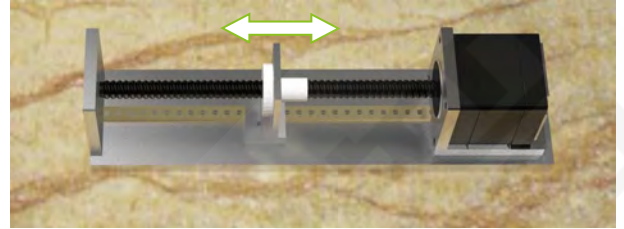

External Motor+ Linear Guide

### 2.Linear Stepper Motor + Guided Rod

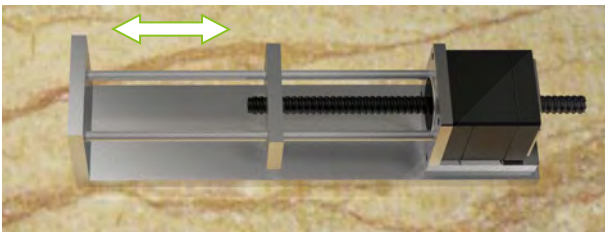

Non-captive Motor + Guided Rod

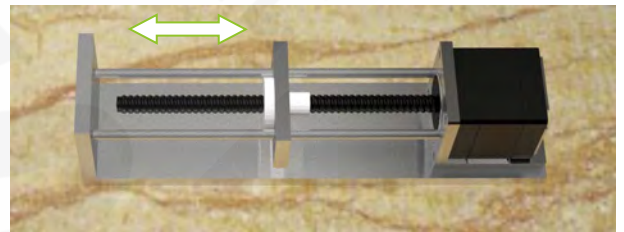

External Motor+ Guided Rod

### 3.Captive Motor mounted to load directly

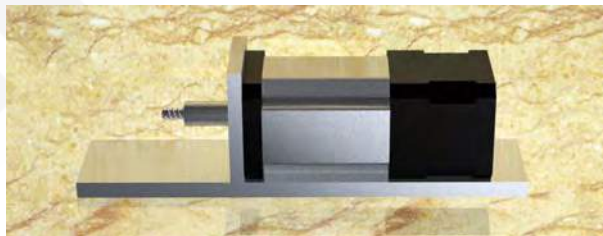

**Warnings**

- 1) Do not dismantle the motor in any case
- 2) No radial force applied to the screw. Don't lift, hang, push or pull the screw during usage or transport.
- 3) No extra lubrication method shall be taken upon the grease and screw. Protect the grease from being wiped off and no other grease shall be used except those from Dings'.
- 4) Anti- dust methods should be taken to protect the screw surface.
- 5) No drop or impact during the usage.
- 6) No lift or other force applied to the wiring leads.
- 7) When using chopper driver, please set the current (RMS) to the rated current of the motor. No over load current is recommended which could bring the failure of motor's over heat or then burning down.
- 8) Operation ambient from -22°C to + 55°C.
- 9) To get the designed lifetime, actual load should be lower than 50% of the calculated data and try to avoid the missing step or stuck. Don't drive the motor beyond its designed stroke for captive structure. Impact, immediately stop or start should be avoided, too.
- 10) Storage condition: Normal ambient. relative humidity <75%, clean, fluent air flow, without corrosivity.

**Typical Electrical Connection**

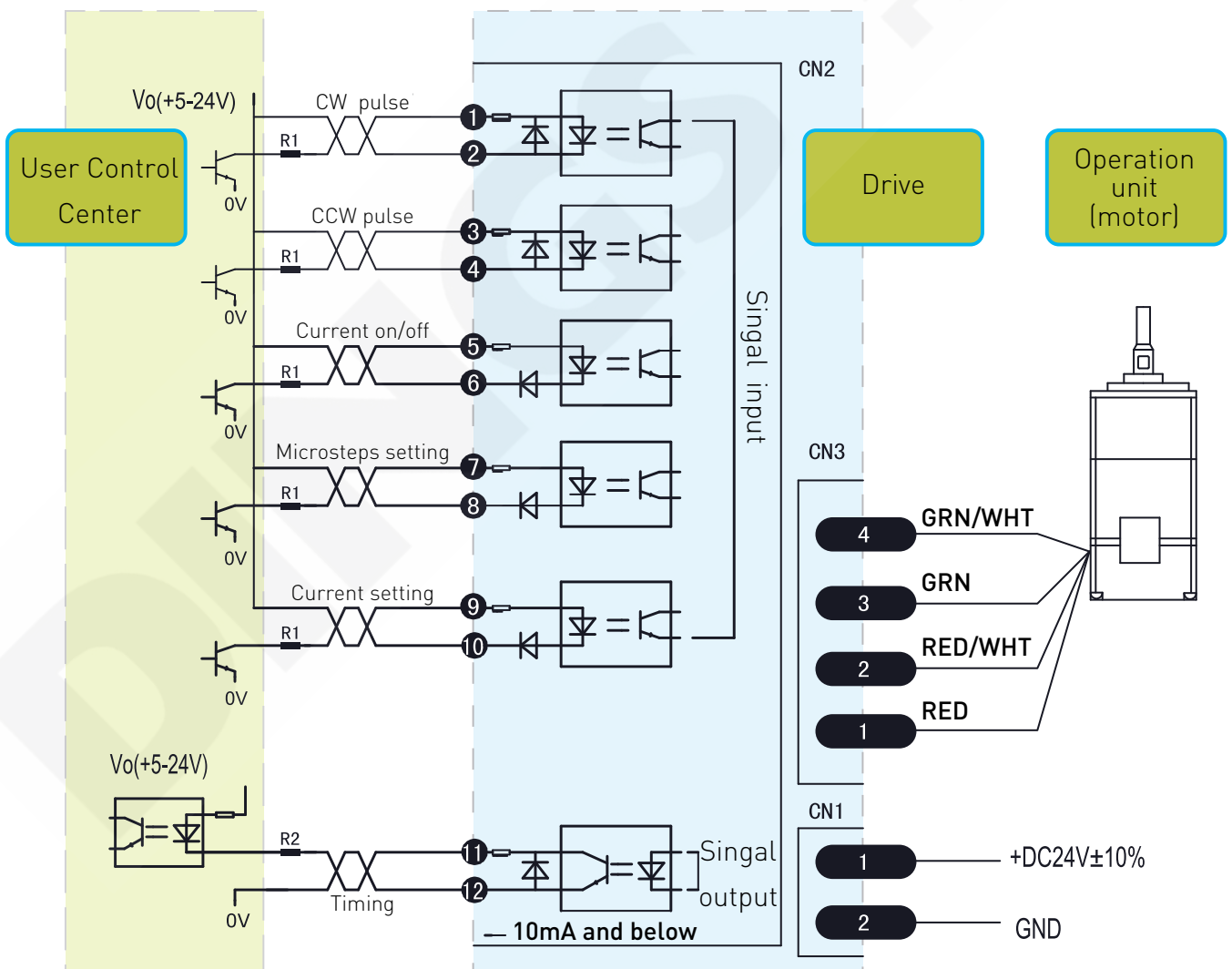



# Hybrid stepper motor ball screw linear actuators

These actuators are external types have 5 different sizes, from 20mm to 57mm. From 0.005mm/step to 0.1mm/step, variety of resolution for options available. Maximum thrust can reach 1600N. Encoder option is available for whole series.



Part number construction

A-55

Ball screw lead code schedule

A-56

Size 8 · 20 mm series

A-57

Size 11 · 28 mm series

A-60

Size 14 · 35 mm series

A-63

Size 17 · 42 mm series

A-66

Size 23 · 57 mm series

A-69

Accessories and options

A-72

Installation guide

A-75

## Part Number Construction

BACK TO

17 E 2 1 10 BS2 4 - 100 R S EK2 - 001

① ② ③ ④ ⑤ ⑥ ⑦ ⑧ ⑨ ⑩ ⑪ ⑫

① Motor Size

CODE	8	11	14	17	23
MOTOR SIZE (mm)	20	28	35	42	57

② Motor Type

E=External Linear

③ Step Angle

2= 2 Phase with 1.8°

4= 2 Phase with 0.9°

④ Motor Length/Stack

1=single stack

2=double stack

⑤ Rated Current/Phase

10=1.0A;

⑥ Ball Screw Code

BS2=2mm

⑦ Number of Lead Wires

4= 4 flying lead wire

6=6 flying lead wire

⑧ Ball Screw Length

100=100mm

⑨ Thread Direction

R= right

L= left

⑩ End Machining

N=None

S=Smooth

C=Customer design

⑪ Optional Accessories

EKX:Encoder(xx=encoder type)

B:brake

X:rear shaft

R=encoder ready

C= customize

N=none

⑫ Customer Sequence Number

**Example**

**Part number** 17E2110BS24-100RSEK2-001

**Description** Size 17 serial hybrid ball screw linear stepper actuator  
 External  
 2 phase with 1.8° step angle  
 Single stack  
 1.0A  
 Ball screw lead 2mm  
 4 flying lead wire  
 Screw length:100mm  
 Right thread direction  
 Smooth screw end  
 Ek2 single output 192 lines

**Ball Screw Lead Code Schedule****BACK TO**

Motor size	20	28	35	42	57				
Diameter	Φ4	Φ5	Φ6	Φ6	Φ8	Φ6	Φ8	Φ10	Φ12
Lead									
1.0 mm	*		*	*	*	*	*		
2.0 mm	*		*	*	*	*	*	*	*
2.5 mm				*			*		
4.0 mm		*						*	
5.0 mm				*			*	*	
6.0 mm			*	*		*			
8.0 mm				*			*		
10.0 mm			*	*	*	*	*	*	*
12.0 mm				*			*		
15.0 mm								*	
20.0 mm								*	

**Electrical Parameter**

Model NO.	Rated Voltage(V)	Current (A)	Resistance ( $\Omega$ )	Inductance (mH)	Lead wire No.	Motor length "L"(mm)
8E2004	3.5	0.4	8.8	2.8	4	20
8E2105	2.55	0.5	5.1	1.5	4	27.2
8E2205	4.4	0.5	8.8	2.7	4	38.1

**Dimensional drawings**

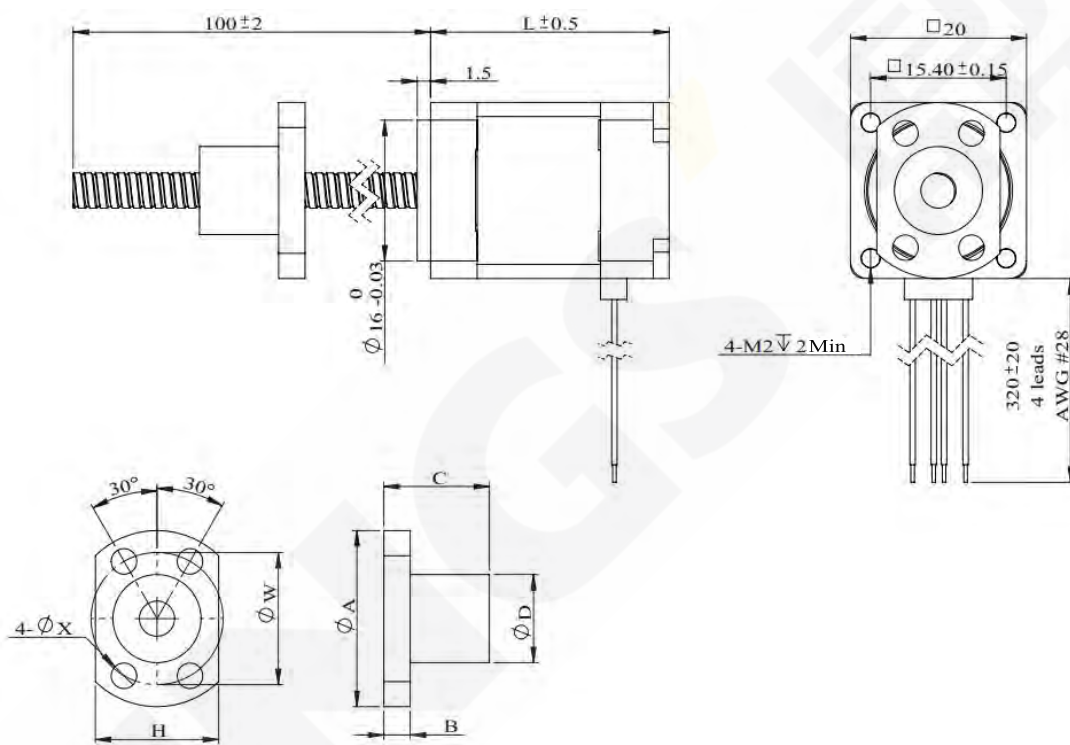

**NOTE:** All drawings are First Angle Projection – ISO Standard. (3D Models are available).



**Size 8 (20 mm) Series****Ball Screw Specification**

<b>Ball screw type</b>	0401		0402										
<b>Ball size</b>	Φ0.8		Φ0.8										
<b>Number of thread</b>	1		1										
<b>Thread direction</b>	Right												
<b>Shaft root dia.</b>	Φ3.3		Φ3.3										
<b>Number of circuit</b>	3.7×1		2.7×1										
<b>Shat, nut material</b>	SCM415H												
<b>Surface hardness</b>	HRC58-62												
<b>Anti-rust treatment</b>	Anti-rust oil												
<b>Nut size</b>	<b>A</b>	<b>B</b>	<b>C</b>	<b>D</b>	<b>H</b>	<b>W</b>	<b>X</b>	<b>Grade</b>	<b>Position accuracy</b>	<b>Total run out</b>	<b>Axial play</b>	<b>Dynamic load(N)</b>	<b>Static load(N)</b>
0401	23	4	17	11	15	17	3.4	C7	±0.05	0.12	0.03	560	790
0402	23	4	19	11	15	17	3.4	C7	±0.05	0.12	0.03	420	570

**Size 8 (20mm) Performance Curves**

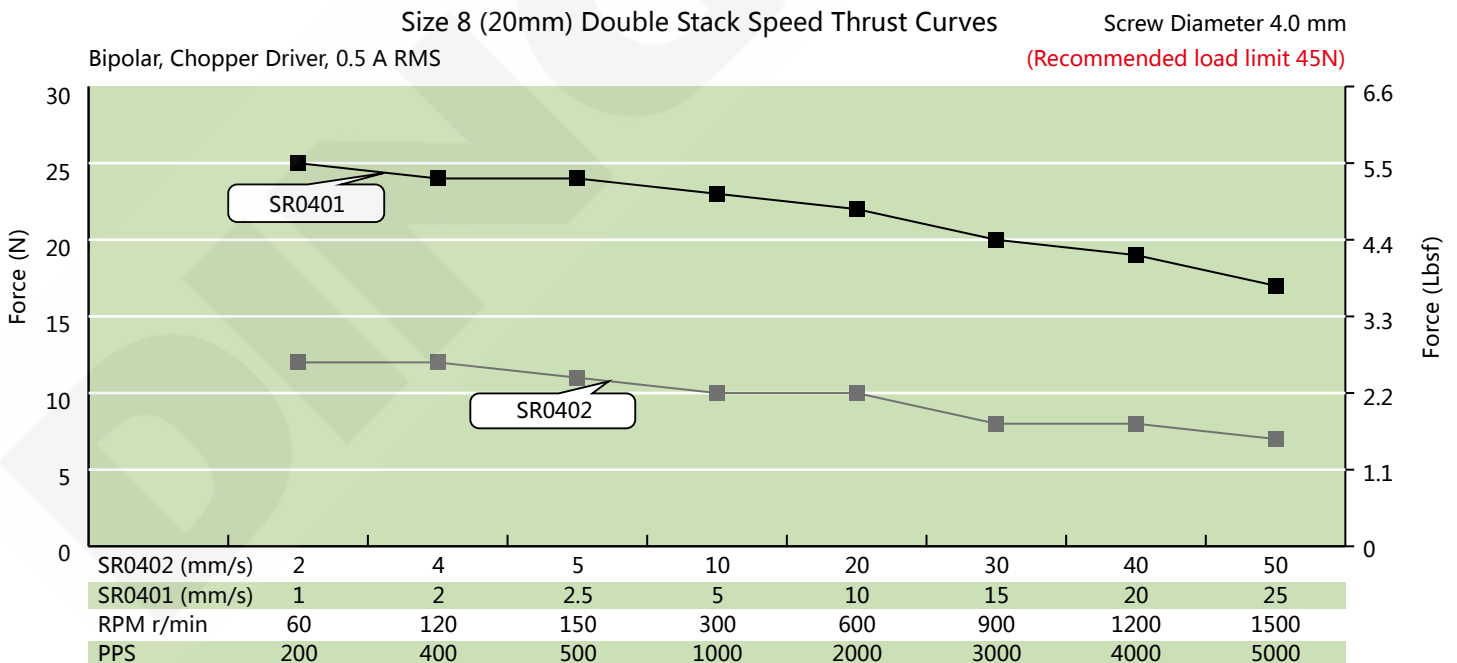
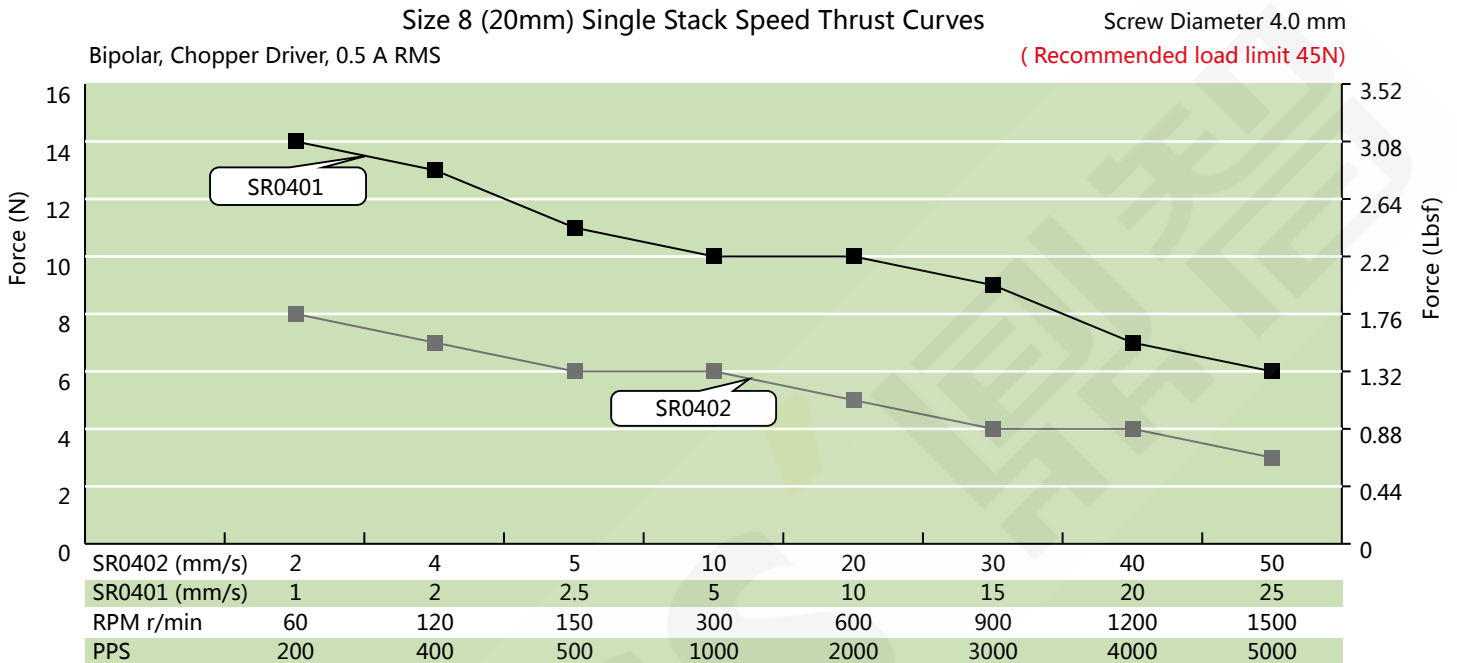

**TEST CONDITION:**

Testing Voltage: 24VDC, Driver Model: DS-2422-001, at rated current (rms) pull-in thrust. Motor's thrust will be changed with different voltage and driver. 50% thrust margin is recommended.

## Size 11 (28 mm) Series

BACK TO

### Electrical Parameter

Model NO.	Rated Voltage(V)	Current (A)	Resistance ( $\Omega$ )	Inductance (mH)	Lead wire No.	Motor length "L"(mm)
11E2110	2.1	1.00	2.1	1.5	4	33.5
11E2209	3.9	0.95	4.1	4.0	4	45

### Dimensional drawings

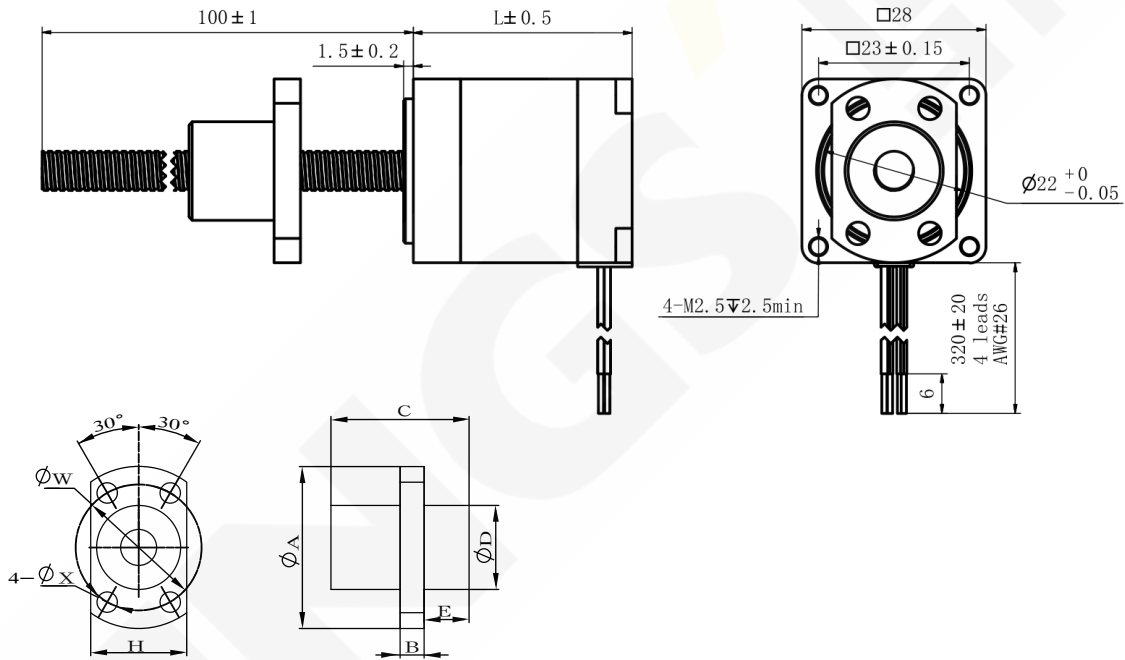

**Ball Screw Specification**

<b>Ball screw type</b>	0601	0602	0606	0610	0504								
<b>Ball size</b>	Φ0.8	Φ0.8	Φ0.8	Φ1.2	Φ0.8								
<b>Number of thread</b>	1	1	2	2	1								
<b>Thread direction</b>	Right												
<b>Shaft root dia.</b>	Φ5.3	Φ5.1	Φ5.2	Φ5.0	Φ4.3								
<b>Number of circuit</b>	3.7×1	2.7×1	1.6×2	1.2×2	2.7×1								
<b>Shat, nut material</b>	SCM415H												
<b>Surface hardness</b>	HRC58-62												
<b>Anti-rust treatment</b>	Anti-rust oil												
<b>Grade</b>	C7												
<b>Nut size</b>	<b>A</b>	<b>B</b>	<b>C</b>	<b>D</b>	<b>H</b>	<b>W</b>	<b>X</b>	<b>E</b>	<b>Position accuracy</b>	<b>Total run out</b>	<b>Axial play</b>	<b>Dynamic load(N)</b>	<b>Static load(N)</b>
0601	26	4	17	13	16	20	3.4		±0.05	0.12	0.03	680	1200
0602	28	4	17	15	19	22	3.4		±0.05	0.12	0.03	750	1450
0606	27	4	17	14	16	21	3.4	5	±0.05	0.12	0.03	870	1600
0610	27	4	23	14	16	21	3.4	7.5	±0.05	0.12	0.02	950	1650
0504	24	4	22	12	16	18	3.4		±0.05	0.12	0.02	470	720

# Size 11 (28 mm) Series

## Size 11 (28mm) Performance Curves

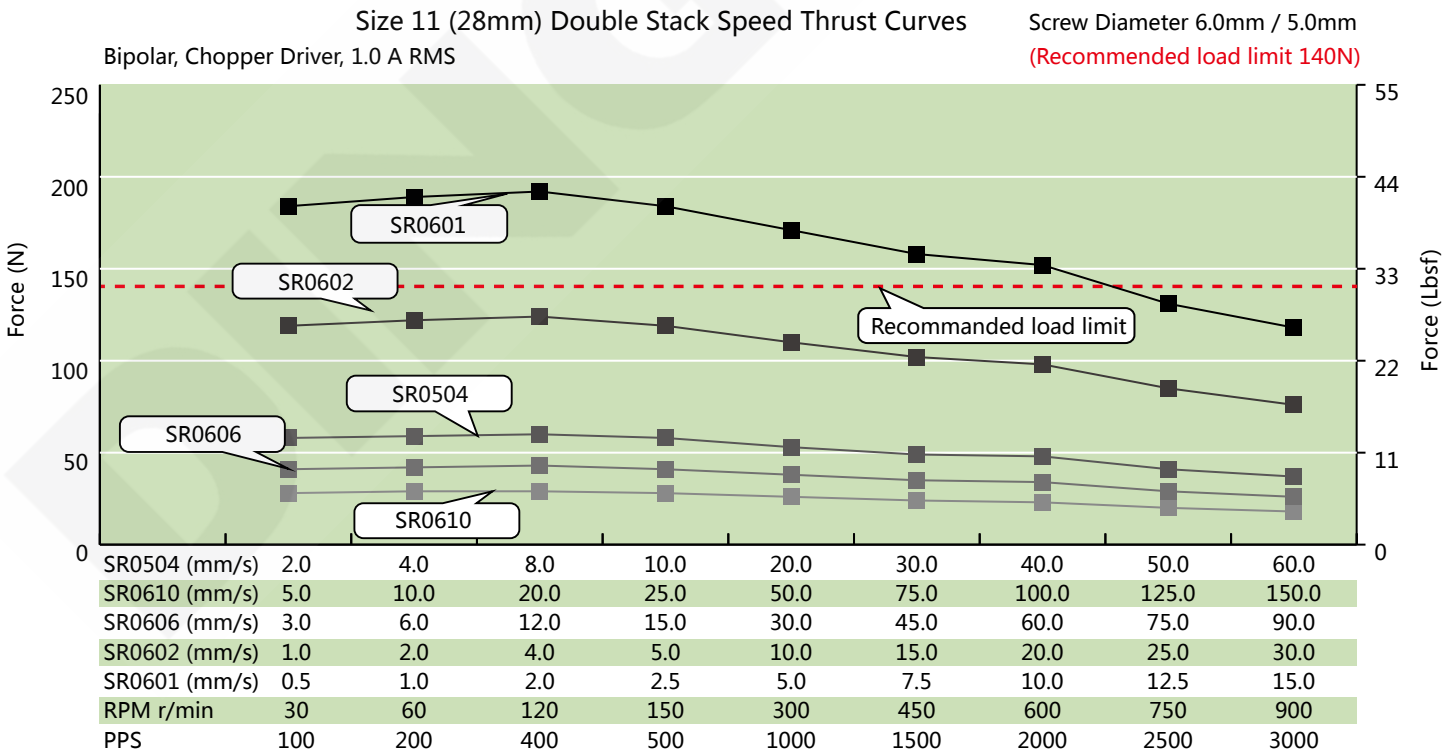
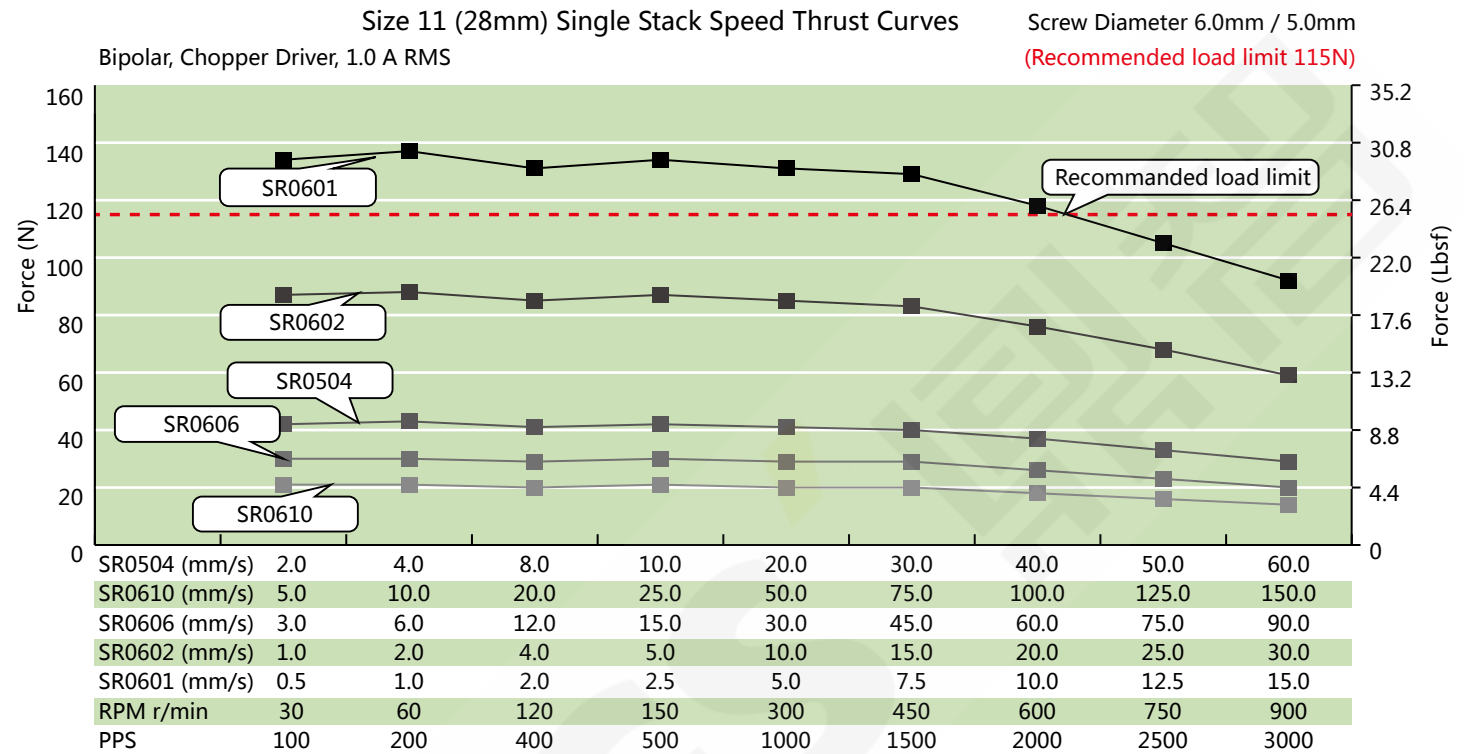

**TEST CONDITION:**

Testing Voltage: 24 VDC, Driver Model: DS-2422-001, at rated current (rms) pull-in thrust. Motor's thrust will be changed with different voltage and driver. 50% thrust margin is recommended.



**Electrical Parameter**

Model NO.	Rated Voltage(V)	Current (A)	Resistance ( $\Omega$ )	Inductance (mH)	Lead wire No.	Motor length "L"(mm)
14E2110	3.5	1.0	3.5	3.6	4	33.6
14E2115	2.7	1.5	1.8	1.9	4	33.6
14E2210	6.0	1.0	6.0	7.2	4	45.6
14E2215	4.0	1.5	2.7	3.2	4	45.6

**Dimensional drawings**

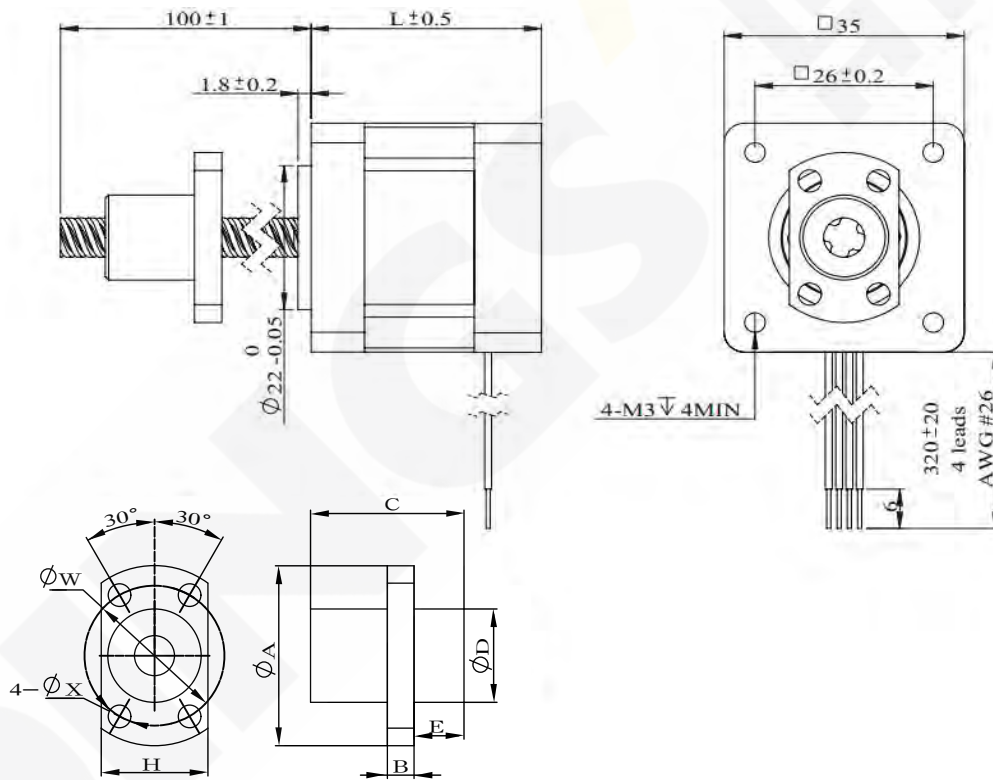

**NOTE:** All drawings are First Angle Projection – ISO Standard. (3D Models are available).

## Size 14 (35 mm) Series

### Ball Screw Specification

<b>Ball screw type</b>	0601	0602	0606	0610	0801	0802	0802.5	0805	0808	0810	0812
<b>Ball size</b>	Φ0.8	Φ0.8	Φ0.8	Φ1.2	Φ0.8	Φ1.5875	Φ1.5875	Φ1.5875	Φ1.5875	Φ1.5875	Φ1.5875
<b>Number of thread</b>	1	1	2	2	1	1	1	1	2	2	2
<b>Thread direction</b>	Right										
<b>Shaft root dia.</b>	Φ5.3	Φ5.1	Φ5.2	Φ5.0	Φ7.3	Φ6.6	Φ6.3	Φ6.6	Φ6.7	Φ6.7	Φ6.7
<b>Number of circuit</b>	3.7×1	2.7×1	1.6×2	1.2×2	3.7×1	3.7×1	2.7×1	2.7×1	1.6×2	1.6×2	1.6×2
<b>Shat, nut material</b>	SCM415H										
<b>Surface hardness</b>	HRC58~62										
<b>Anti-rust treatment</b>	Anti-rust oil										
<b>Grade</b>	C7										

Nut size	A	B	C	D	H	W	X	E	Position accuracy	Total run out	Axial play	Dynamic load(N)	Static load(N)
0601	26	4	17	13	16	20	3.4		±0.05	0.12	0.03	680	1200
0602	28	4	17	15	19	22	3.4		±0.05	0.12	0.03	750	1450
0606	27	4	17	14	16	21	3.4	5	±0.05	0.12	0.03	870	1600
0610	27	4	23	14	16	21	3.4	7.5	±0.05	0.12	0.03	950	1650
0801	29	4	17	16	18	23	3.4		±0.05	0.12	0.03	780	1650
0802	37	5	24	20	22	29	4.5		±0.05	0.12	0.03	2400	4100
0802.5	29	4	16	16	18	23	3.4		±0.05	0.12	0.03	1850	3000
0805	31	4	28	18	20	25	3.4		±0.05	0.12	0.03	1850	3000
0808	31	4	20	18	20	25	3.4	6	±0.05	0.12	0.03	2200	3800
0810	31	4	20	18	20	25	3.4	7	±0.05	0.12	0.03	2200	3800
0812	31	4	24	18	20	25	3.4	6	±0.05	0.12	0.03	2200	3800

## Size 14 (35 mm) Series

### Size 14 (35mm) Performance Curves

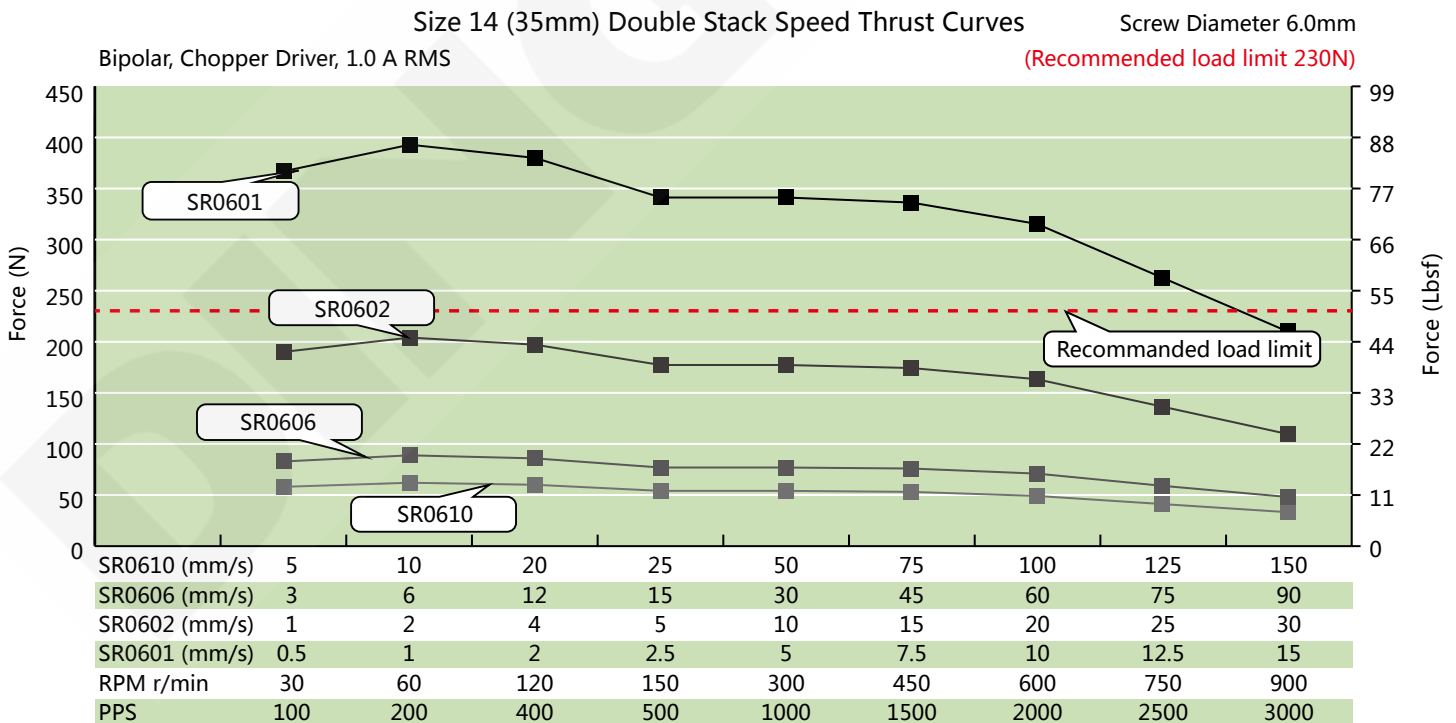
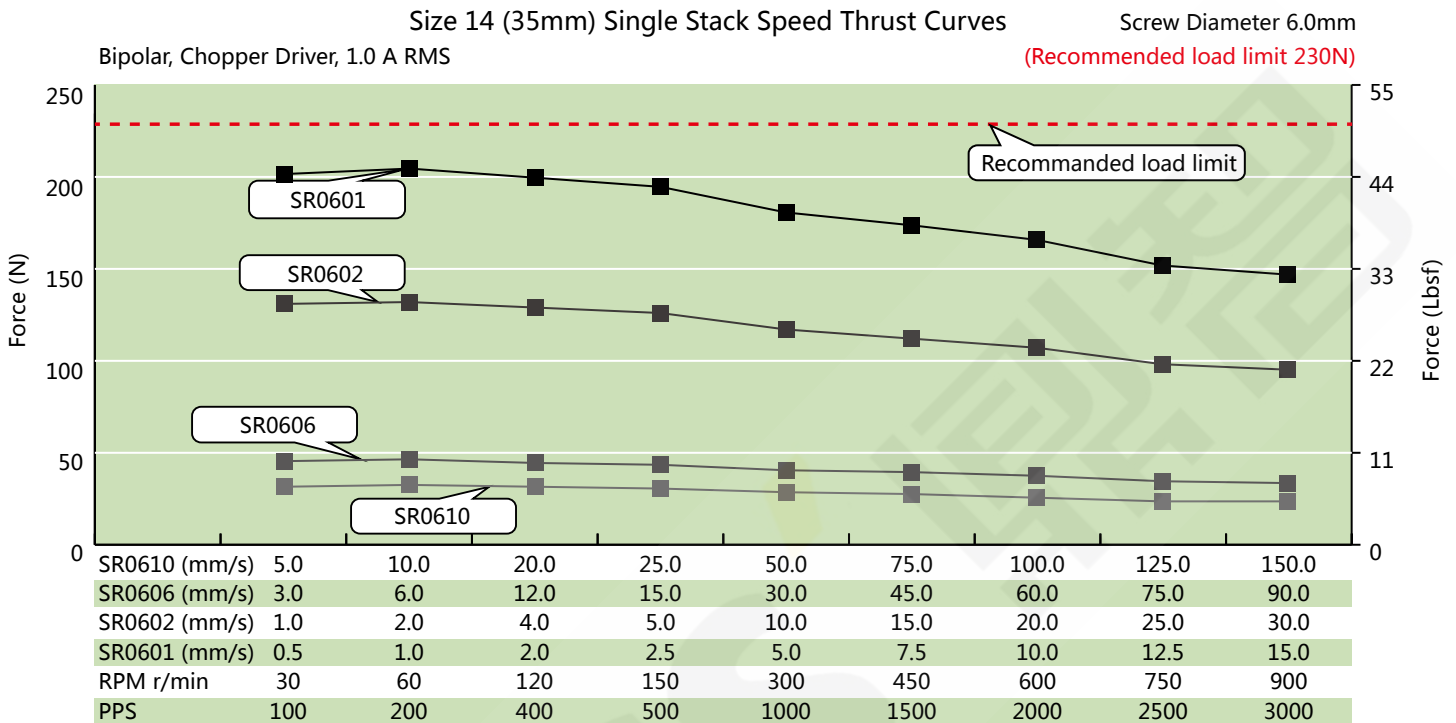

**TEST CONDITION:**

Testing Voltage: 24VDC, Driver Model: DS-2422-001, at rated current (rms) pull-in thrust. Motor's thrust will be changed with different voltage and driver. 50% thrust margin is recommended.

## Size 17 (42 mm) Series

BACK TO

### Electrical Parameter

Model NO.	Rated Voltage(V)	Current (A)	Resistance ( $\Omega$ )	Inductance (mH)	Lead wire No.	Motor length "L"(mm)
17E2110	3.8	1.0	3.8	5.0	4	34.1
17E2115	2.78	1.5	1.85	2.2	4	34.1
17E2212	4.56	1.2	3.8	8.0	4	48.1
17E2225	2.5	2.5	1.0	1.8	4	48.1

### Dimensional drawings

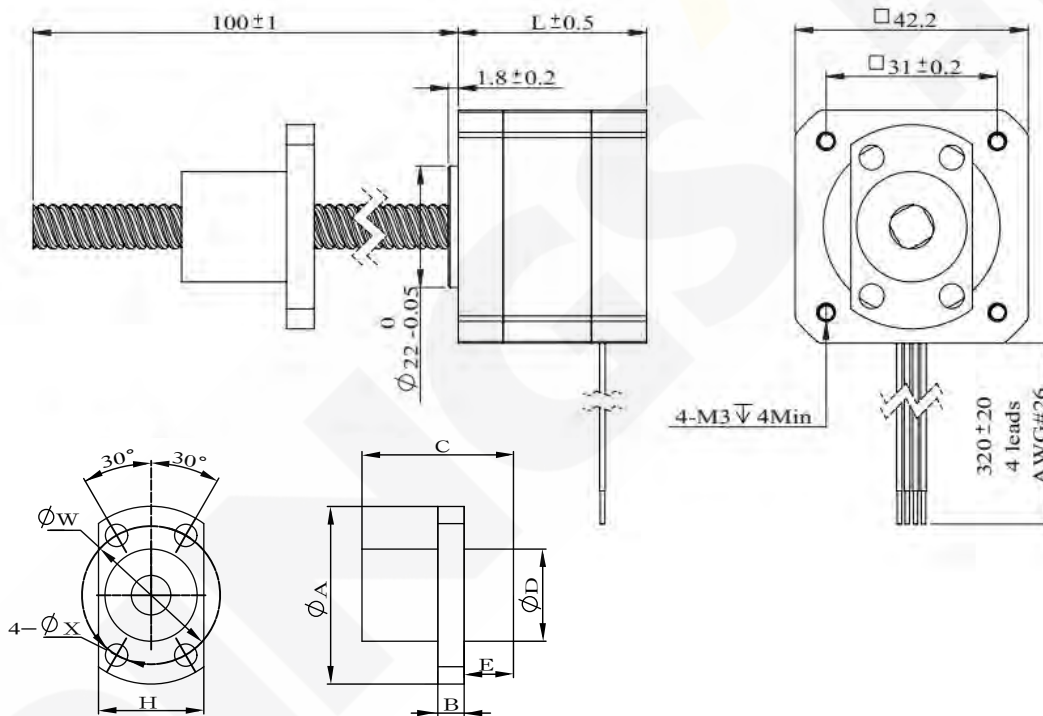

**Ball Screw Specification**

<b>Ball screw type</b>	0801	0802	0802.5	0805	0808	0810	0812						
<b>Ball size</b>	Φ0.8	Φ1.5875	Φ1.5875	Φ1.5875	Φ1.5875	Φ1.5875	Φ1.5875						
<b>Number of thread</b>	1	1	1	1	2	2	2						
<b>Thread direction</b>	Right												
<b>Shaft root dia.</b>	Φ7.3	Φ6.6	Φ6.3	Φ6.6	Φ6.7	Φ6.7	Φ6.7						
<b>Number of circuit</b>	3.7×1	3.7×1	2.7×1	2.7×1	1.6×2	1.6×2	1.6×2						
<b>Shaft, nut material</b>	SCM415H												
<b>Surface hardness</b>	HRC58-62												
<b>Anti-rust treatment</b>	Anti-rust oil												
<b>Grade</b>	C7												
<b>Nut size</b>	<b>A</b>	<b>B</b>	<b>C</b>	<b>D</b>	<b>H</b>	<b>W</b>	<b>X</b>	<b>E</b>	<b>Position accuracy</b>	<b>Total run out</b>	<b>Axial play</b>	<b>Dynamic load(N)</b>	<b>Static load(N)</b>
0801	29	4	17	16	18	23	3.4		±0.05	0.12	0.03	780	1650
0802	37	5	24	20	22	29	4.5		±0.05	0.12	0.03	2400	4100
0802.5	29	4	16	16	18	23	3.4		±0.05	0.12	0.03	1850	3000
0805	31	4	28	18	20	25	3.4		±0.05	0.12	0.03	1850	3000
0808	31	4	20	18	20	25	3.4	6	±0.05	0.12	0.03	2200	3800
0810	31	4	20	18	20	25	3.4	7	±0.05	0.12	0.03	2200	3800
0812	31	4	24	18	20	25	3.4	6	±0.05	0.12	0.03	2200	3800



# Size 17 (42 mm) Series

## Size 17 (42mm) Performance Curves

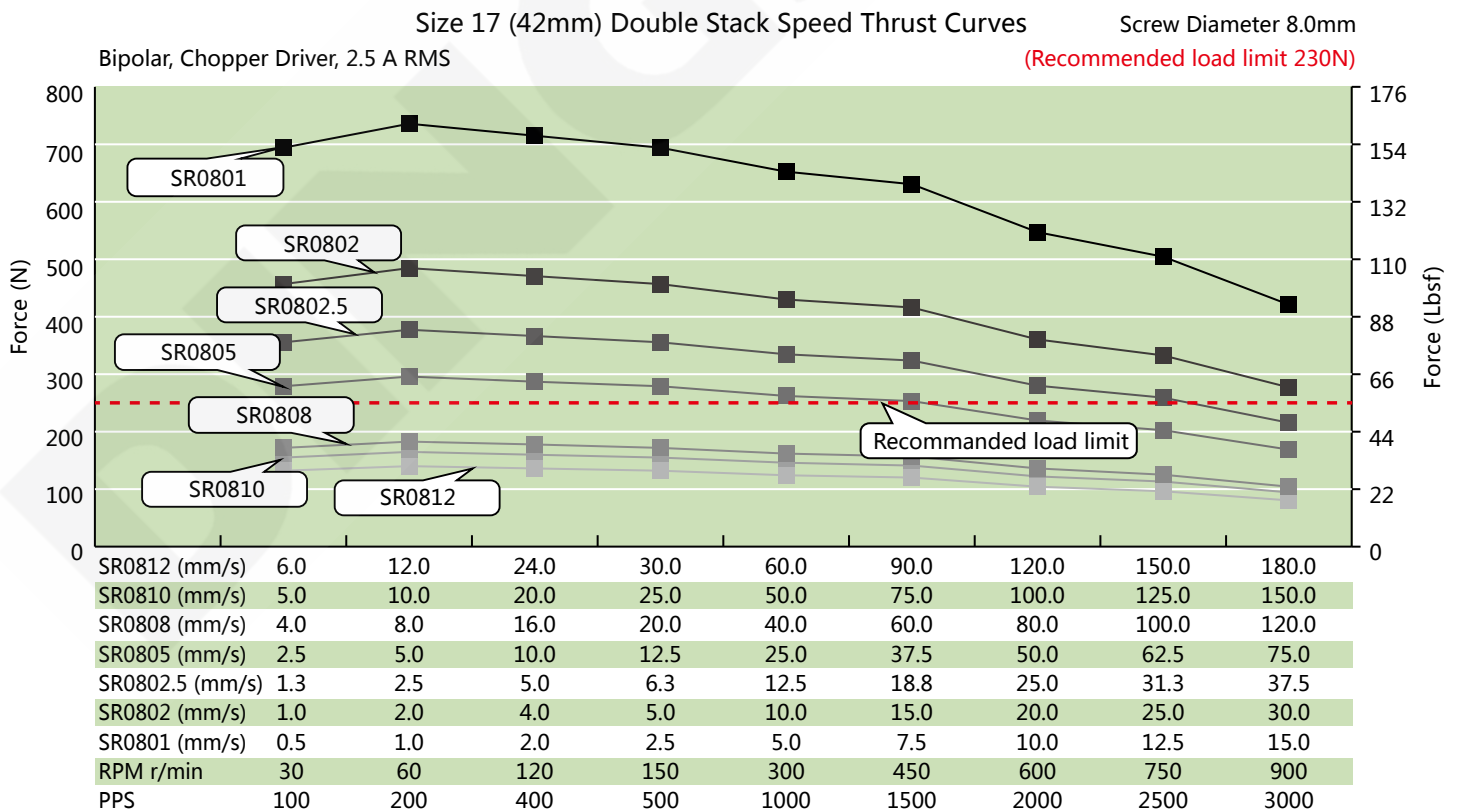
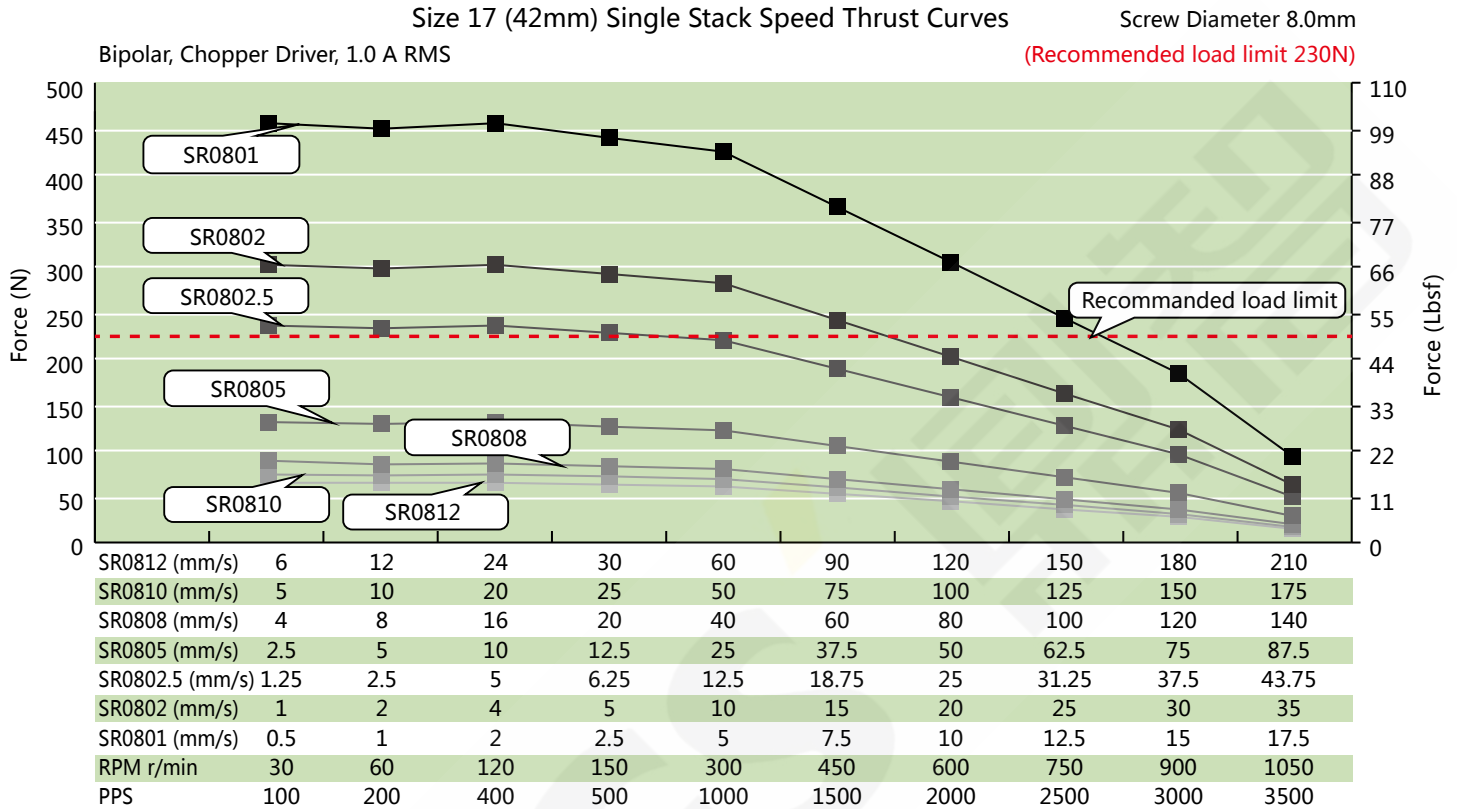

**TEST CONDITION:**

Testing Voltage: 24VDC, Driver Model: DS-2422-001, at rated current (rms) pull-in thrust. Motor's thrust will be changed with different voltage and driver. 50% thrust margin is recommended.

**Electrical Parameter**

Model NO.	Rated Voltage(V)	Current (A)	Resistance ( $\Omega$ )	Inductance (mH)	Lead wire No.	Motor length "L"(mm)
23E2120	3.5	2.0	1.75	4.1	4	45
23E2130	2.4	3.0	0.8	1.7	4	45
23E2225	5.0	2.5	2.0	5.2	4	65
23E2240	2.8	4.0	0.7	2.0	4	65

**Dimensional drawings**

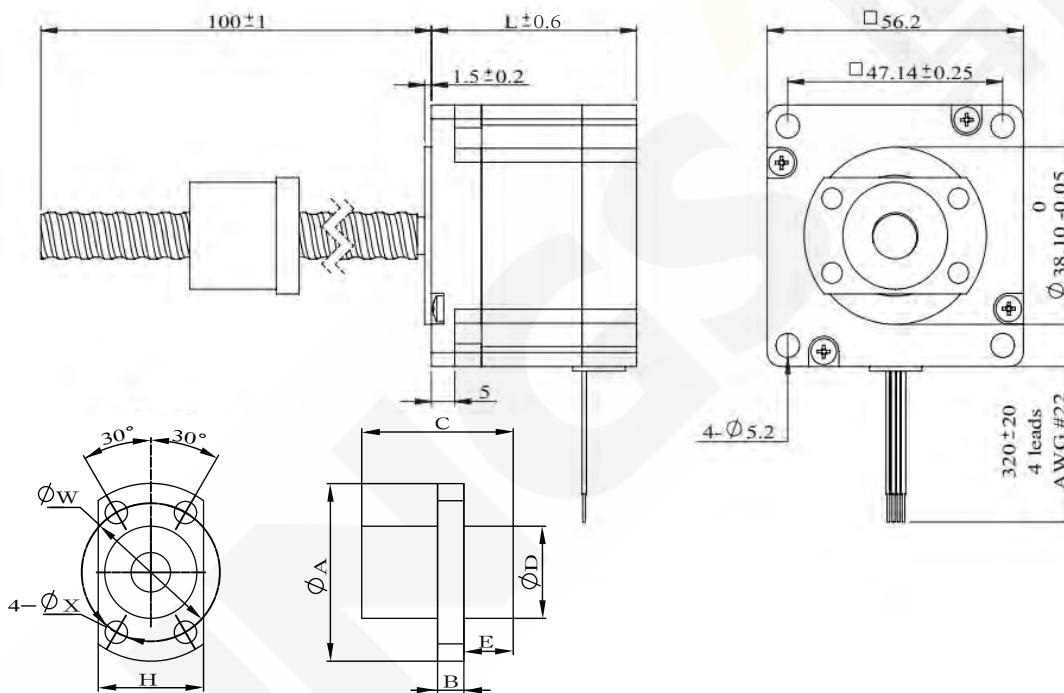

**NOTE:** All drawings are First Angle Projection – ISO Standard. (3D Models are available).

## Size 23 (57 mm) Series

### Ball Screw Specification

<b>Ball screw type</b>	1002	1004	1005	1010	1015	1020	1202	1210					
<b>Ball size</b>	Φ1.5875	Φ2.0	Φ2.0	Φ2.0	Φ2.0	Φ1.5875	Φ1.5875	Φ2.381					
<b>Number of thread</b>	1	1	1	2	2	4	1	2					
<b>Thread direction</b>	Right												
<b>Shaft root dia.</b>	Φ8.6	Φ8.2	Φ8.2	Φ8.4	Φ8.4	Φ8.7	Φ10.6	Φ10.2					
<b>Number of circuit</b>	3.7×1	2.7×1	2.7×1	1.6×1	1.6×2	0.7×2	3.7×1	1.7 x 2					
<b>Shat, nut material</b>	SCM415H												
<b>Surface hardness</b>	HRC58~62												
<b>Anti-rust treatment</b>	Anti-rust oil												
<b>Grade</b>	C7												
Nut size	A	B	C	D	H	W	X	E	Position accuracy	Total run out	Axial play	Dynamic load(N)	Static load(N)
1002	40	5	24	23	25	32	4.5		±0.05	0.12	0.03	2700	5300
1004	41	5	28	24	26	33	4.5		±0.05	0.12	0.03	3000	5200
1005	40	5	26	23	25	32	4.5		±0.05	0.12	0.03	3000	5200
1010	40	5	24	23	25	32	4.5	6	±0.05	0.12	0.03	3300	5900
1015	40	5	33	23	25	32	4.5	6	±0.05	0.12	0.03	3300	6400
1020	37	5	23	20	22	29	4.5	5	±0.05	0.12	0.03	2100	4000
1202	42	5	24	25	27	34	4.5		±0.05	0.12	0.03	3000	6400
1210	41	5	30	24	26	33	4.5	9.5	±0.05	0.12	0.03	5100	9800

## Size 23 (57 mm) Series

### Size 23 (57mm) Performance Curves

Size 23 (57mm) Single Stack Speed Thrust Curves

Screw Diameter 10.0mm / 12.0mm

Bipolar, Chopper Driver, 2.0 A RMS

(Recommended load limit 910N)

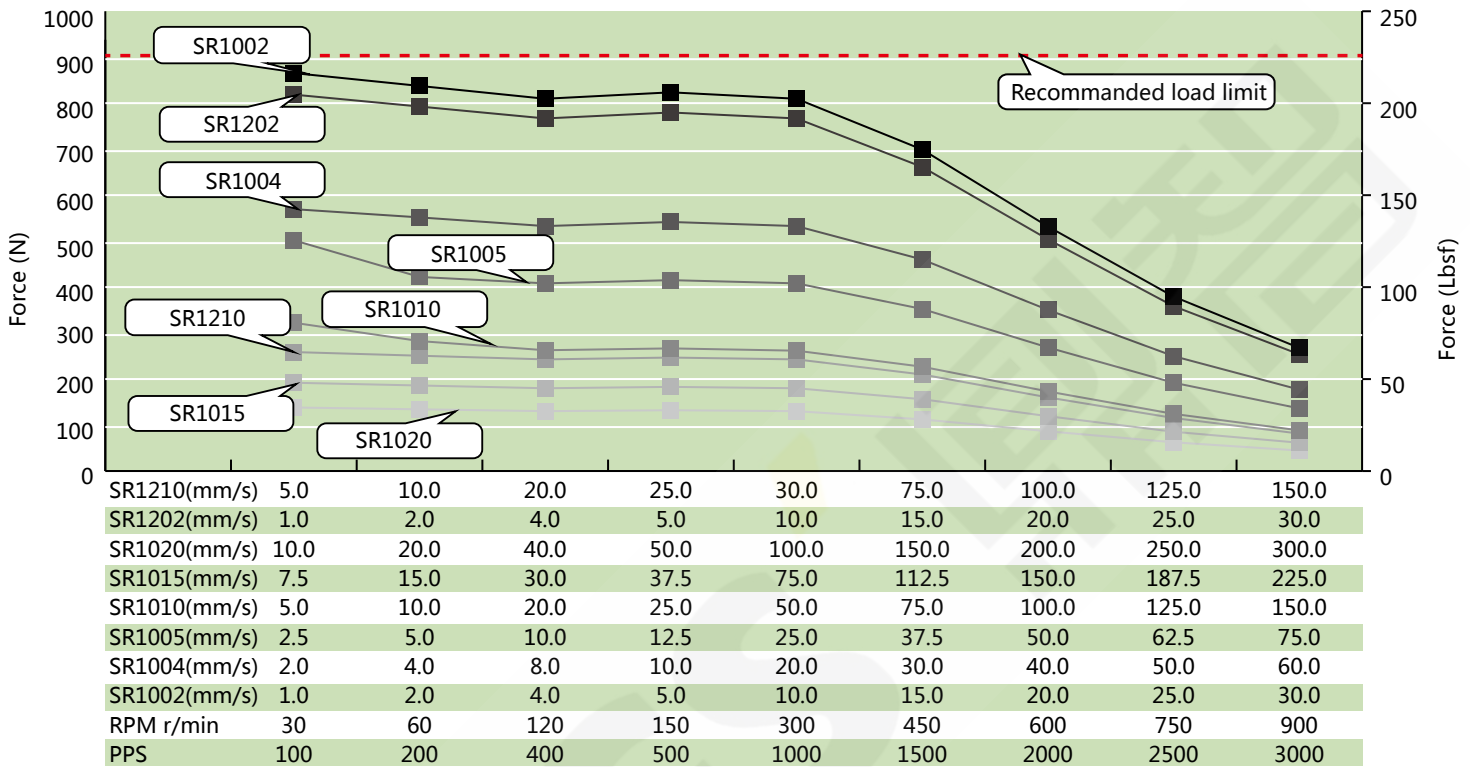

Size 23 (57mm) Double Stack Speed Thrust Curves

Screw Diameter 10.0mm / 12.0mm

Bipolar, Chopper Driver, 4.0 A RMS

(Recommended load limit 910N)

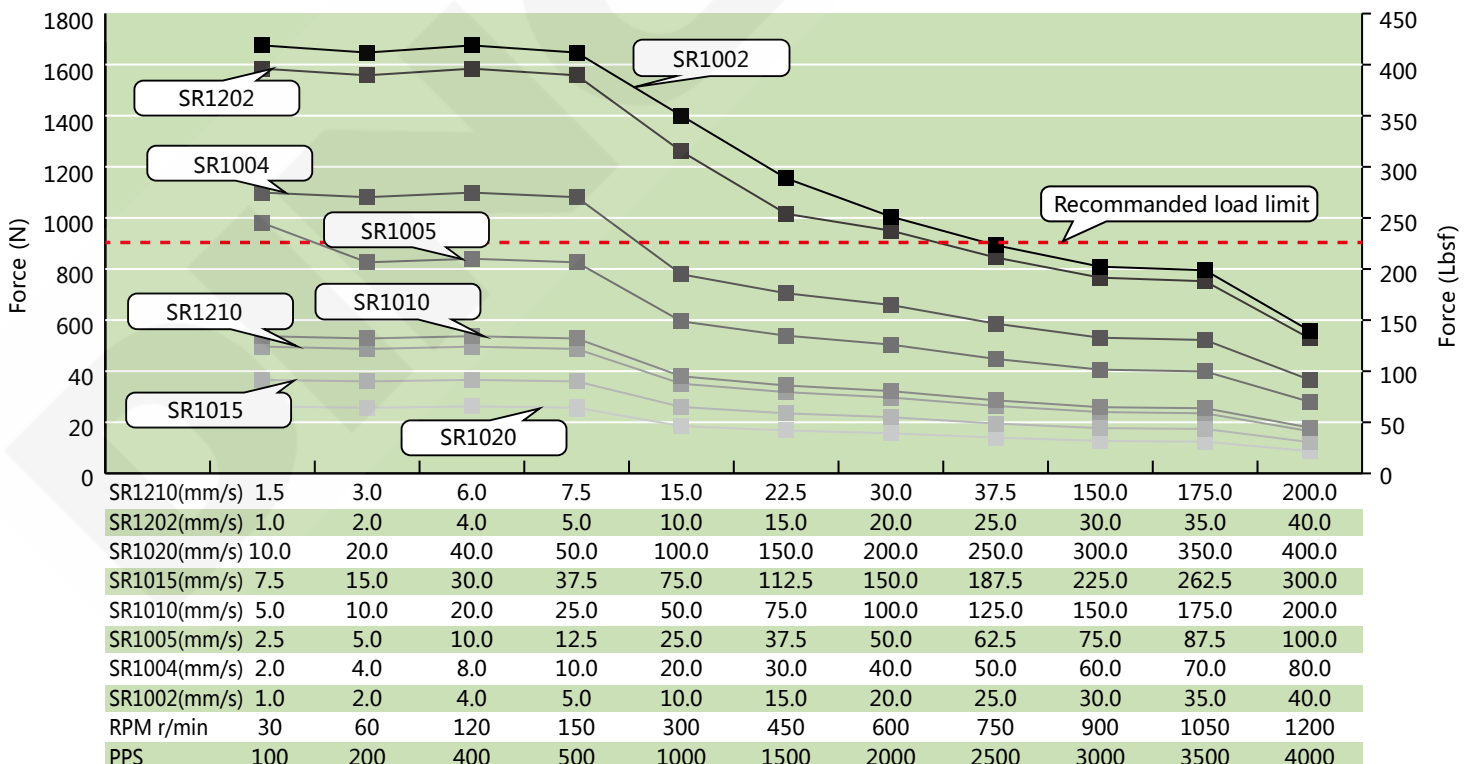

**TEST CONDITION:**

Testing Voltage: 40VDC, Driver Model: DS-5045-003, at rated current (rms) pull-in thrust. Motor's thrust will be changed with different voltage and driver. 50% thrust margin is recommended.

## Accessories and Options

BACK TO

### ■ Ball Screw End Machining

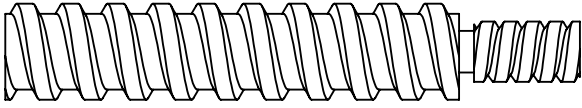
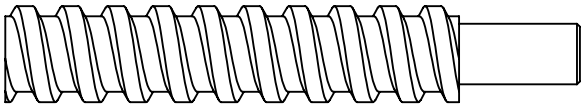
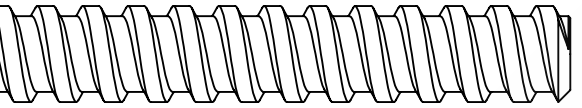
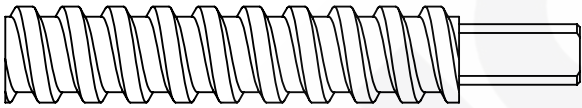
	<p>Thread End</p>	<p>Customized screw end machining are welcome, please contact DINGS' engineer for more details.</p>
	<p>Smooth End</p>	
	<p>None</p>	
	<p>Customized</p>	



## Accessories and Options

### Encoder

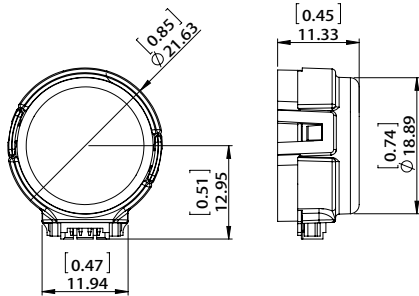

EK1 Encoder – single ended output

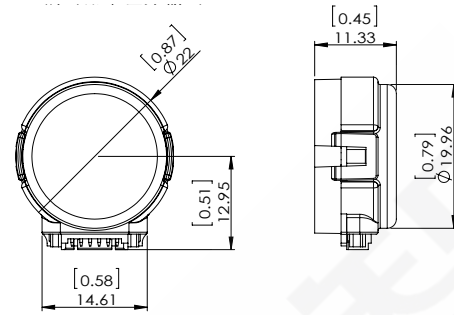

EK1 Encoder – differential output

#### EK1 Encoder (Used for Size 8, 11, 14, 17 Motor)\* No index

Resolution	100	108	120	125	128	200	250	256	300	360	400	500
Single ended output	0	1	2	3	4	5	6	7	8	9	10	11
Differential output	A	B	C	D	E	F	G	H	I	J	K	L

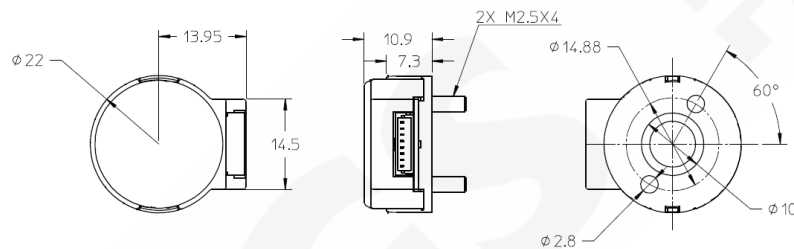

EK1 Encoder – differential output

#### EK5 Encoder (Used for Size 8, 11, 14, 17 Motor)\* With index

Resolution	360	500	512	1000	1024	2000	2048
Single ended output	0	1	2	3	4	5	6
Differential output	A	B	C	D	E	F	G

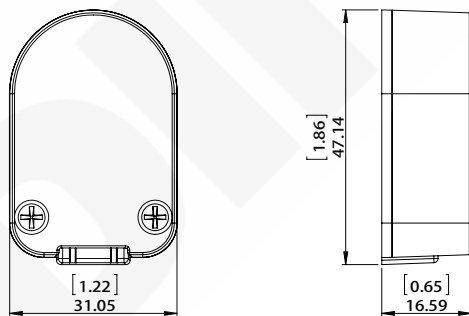

EK2 Encoder – single ended output

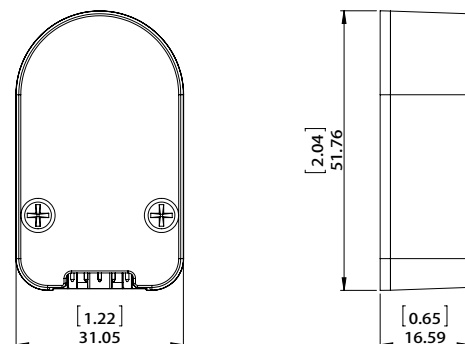

EK2 Encoder – differential output

#### EK2 Encoder (Used for Size 14, 17, 23 Motor)

Resolution	50	100	192	200	250	256	360	400	500	720	900	1000	1250	2000	2500	4000	5000
Single ended output	0	1	2	3	4	5	6	7	8	9	10	11	12				
Differential output	A	B	C	D	E	F	G	H	I	J	K	L	M	N	O	P	Q

## Accessories and Options

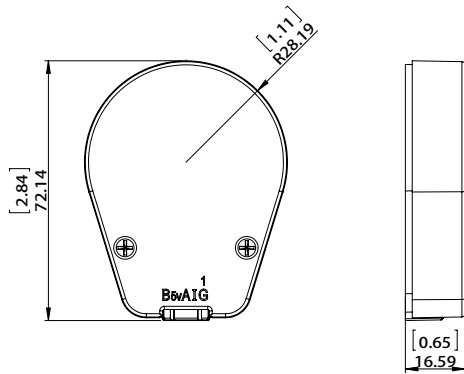

EK3 Encoder – single ended output

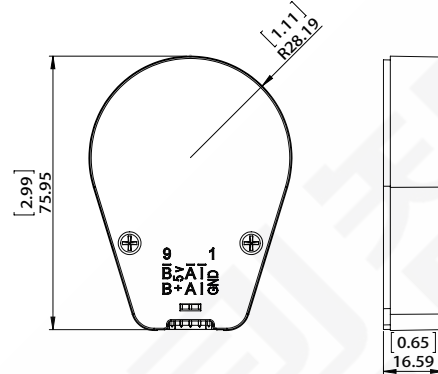

EK3 Encoder – differential output

### ● EK3 Encoder (Used for Size 23 Motor)

Resolution	64	100	200	500	1000	1800	2000	2500	3600	4000	5000	7200	8000	10000
Single ended output	0	1	2	3	4	5	6	7	8					
Differential output		A	B	C	D	E	F	G	H	I	J	K	L	M

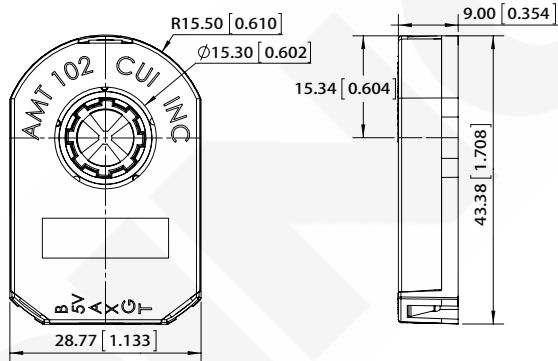

EK4 Encoder-single ended output (size14,17)

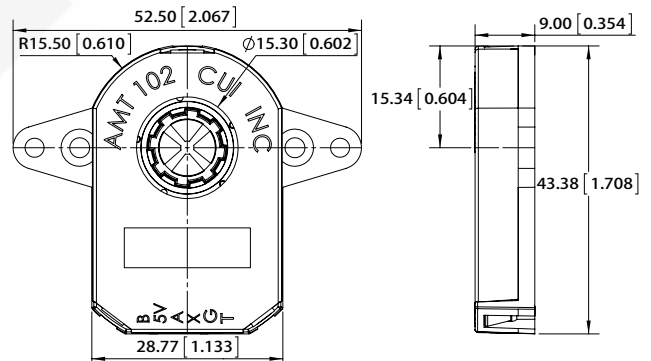

EK4 Encoder-single ended output (size23)

### ● EK4 Encoder (Used for Size 14, 17, 23 Motor)

Resolution	48	96	100	125	192	200	250	256	384	400	500	512	800	1000	1024	2048
Single ended output	0	1	2	3	4	5	6	7	8	9	10	11	12	13	14	15
Differential output	-	-	-	-	-	-	-	-	-	-	-	-	-	-	-	-

### ■ Optional Brake (See Pages A-50~A-51)

**■ PRECAUTION OF HANDLING AND OPERATING**

This is the product which integrated the Motor shaft and the screw shaft, repair is not possible, if either motor or ball screw is damaged.

**● PRECAUTION FOR OPERATING**

1. Before use, please read instruction manuals and follow the precautions below.
2. Do not hit or drop the shaft, do not apply Axial load or radial load exceeding specifications, it may cause malfunction.
3. Before use, please check that the product has no defect, and product is the same as your order.
4. Do not disassemble each component, dust may get inside the product. It may deteriorate accuracy.
5. Please prevent contamination from dust or swarf. Dust or swarf may cause damage to ball screw, Which lead to deteriorating the function.
6. Lubrication is required under the ball screw operation. Lubrication condition should be checked every 2-3 months. If grease is contaminated, remove old grease and replace with new one.
7. Do not use the motor exceeding our specification in load or speed.
8. Allowing ball screw nut to over-run may result in malfunctioning due to balls escaping, damage to recycling parts, and indentation on the raceways. Therefore ball screw nut must never be allowed to over-run. If over-running occurs, contact us for an inspection with charge.
9. Do not hold the motor lead wire. It is for fixation, do not use it as movement.
10. The motor torque and speed characteristics may vary from the specifications, depending on the load conditions or Driver used. Please adjust as appropriate.
11. The motor has a resonant point within the specifications. Please avoid it when in use.

**● PRECAUTION FOR SAFETY**

1. If abnormal odor, noise, smoke, overheating, or vibration occurs, stop operation immediately and turn the power off.
2. Do not use the exceeding rated current.
3. The motor may overheat depending on the load condition or Driver used.  
Make sure that the motor surface temperature dose not exceed 80 when in use.
4. Check the wire connection type, Drive system, and phase sequence. Inappropriate connection leads to malfunction.
5. Do not bend ,pull or pinch the motor lead wire.
6. Do not touch moving parts during operation.
7. Disconnect from the controller before performing dielectric withstanding voltage test of the motor or Insulation test.
8. Please switch off the Driver ,when inspection or maintenance.

## Installation Guide

### ● OPERATING ENVIRONMENT

1. Operating environment should be 0-40 °C in temperature and 20-80%RH in humidity. Do not use it under dew condensation, corrosive gas or inflammable gas environment.
2. Do not use it under strong electric field, strong magnetic field.
3. Please prevent from swarf, oil mist, cutting fluid, water/moisture, salt spray, organic solvent and other contamination.
4. The motor can not be used under the vibration, impact, vacuum, and other special environment.

### ● BALL SCREW MAINTENANCE

#### 1. BALL SCREW PAIR PROTECTION DEVICE

(1) the use of the ball screw in the use of the process, is strictly prohibited dust or dirt entering, and therefore must be equipped with protective device.

(2) the ball screw pair is exposed on the machine tool, and a closed protective cover shall be adopted, such as the use of a coil spring steel tape sleeve, a telescopic sleeve and a folding sleeve, etc.. When you install, connect one end of the shield to the side of the ball nut. The other end is fixed on the supporting seat of the ball screw.

(3) the position of the ball screw is located in a position, and the sealing ring is used to protect the ball screw. Sealing ring is arranged on both ends of the nut. Contact and non contact type two sealing ring.

#### 2. LUBRICATION OF BALL SCREW

(1) the ball screw pair is usually used for two kinds of lubricants, lithium based grease and the main shaft oil. Lubricating grease generally and in the thread rolling and nut shell space, spindle oil through the shell of an oil hole injection nut of the space.

(2) use of the process, every half a year to replace the grease, clean the old grease, coated with new fat. The ball screw with the main shaft oil lubrication, can be used in the machine tool for each class before refueling.

# PM stepper linear actuators

DINGS' provide three sizes - 20 mm, 25 mm and 36 mm PM stepper linear actuators. For each size, three types of linear structures are available - non-captive, external and Kaptive. Step travel varies from 0.00625 to 0.3333 mm/step and the max. linear force can reach 115 N.



**External**



**Non-Captive**



**Kaptive**

Part number construction	A-78
Product overview	A-79
20 mm series	A-80
25 mm series	A-84
36 mm series	A-88



## Part Number Construction

[BACK TO](#)

E 25 P A 1 4 A 05 - X - 001

① ② ③ ④ ⑤ ⑥ ⑦ ⑧ ⑨ ⑩

- ① **Linear Structure**
  - E = External
  - N = Non-captive
  - K = Kaptive
- ② **Motor Size**
  - 20 mm
  - 25 mm
  - 36 mm
- ③ **PM Stepper Motor**
- ④ **Mounting**
  - A = Flange and wiring box
  - B = Flange only
  - C = Wiring box only
  - D = No flange or wiring box
- ⑤ **Step Angle**
  - 1 = 7.5°
  - 2 = 15°
- ⑥ **Wiring Number**
  - 4 = bi-polar (4 wiring)
  - 6 = uni-polar (6 wiring)
- ⑦ **Lead Code**
- ⑧ **Winding Code**
  - 05 = 5V
  - 12 = 12V
- ⑨ **Screw Stroke / Length**
  - Kaptive - stroke distance
  - Non-captive - total length of screw
  - External - screw extension length from the mounting flange
- ⑩ **Customization Sequence Number**

### Example

**Naming code**

E25PA14AA05-X-001

**Description**

25 mm size  
 External type with mounting flange and wiring box  
 7.5°step angle  
 5V winding  
 Screw A  
 Bi-polar  
 Screw extension X mm  
 Customization sequence is 001



**External**



**Non-Captive**



**Kaptive**

■ **Over view**

Motor size (mm)	Screw diameter (mm)	Screw lead (mm)	Travel per step (mm)		Max. Thrust force (N)	Power consumption (W)	Screw lead code
			7.5°	15°			
Φ20	Φ3.5	0.6096	0.0127	0.0254	35	3.4	AA
		1.2192	0.0254	0.0508			B
		2.4384	0.0508	0.1016			J
Φ25	Φ3.5	0.6096	0.0127	0.0254	65	3.9	AA
		1.2192	0.0254	0.0508			B
		2.4384	0.0508	0.1016			J
Φ36	Φ6.35	0.6096	0.0127	0.0254	115	5.6	AA
		1.2192	0.0254	0.0508			B
		2.4384	0.0508	0.1016			J

## 20 mm Series

### Parameters

[BACK TO](#)

20 mm frame				
<b>Polarity</b>	Bi-polar			
<b>Linear structure</b>	Kaptive, Non-captive, External			
<b>Step angle</b>	7.5°		15°	
<b>Winding</b>	5V	12V	5V	12V
<b>Phase Current</b>	380mA	160mA	380mA	145mA
<b>Phase resistance</b>	13Ω	74.5Ω	13Ω	83.5Ω
<b>Phase inductance</b>	8.5mH	45mH	6mH	40mH
<b>Power consumption</b>	3.4W			
<b>Rotor inertia</b>	1.05gcm <sup>2</sup>			
<b>Insulation class</b>	B			
<b>Insulation resistance</b>	100MΩ			
<b>Mass</b>	35g			

### Travel per Step and Screw Lead Code

Step angle	Screw lead		Travel per step		Screw lead code
	mm	inch	mm	inch	
7.5°	0.6096	0.024	0.0127	0.0005	AA
	1.2192	0.048	0.0254	0.0010	B
	2.4384	0.096	0.0508	0.0020	J
15°	0.6096	0.024	0.0254	0.0010	AA
	1.2192	0.048	0.0508	0.0020	B
	2.4384	0.096	0.1016	0.0040	J

**Dimensional Drawings**

**1. External**

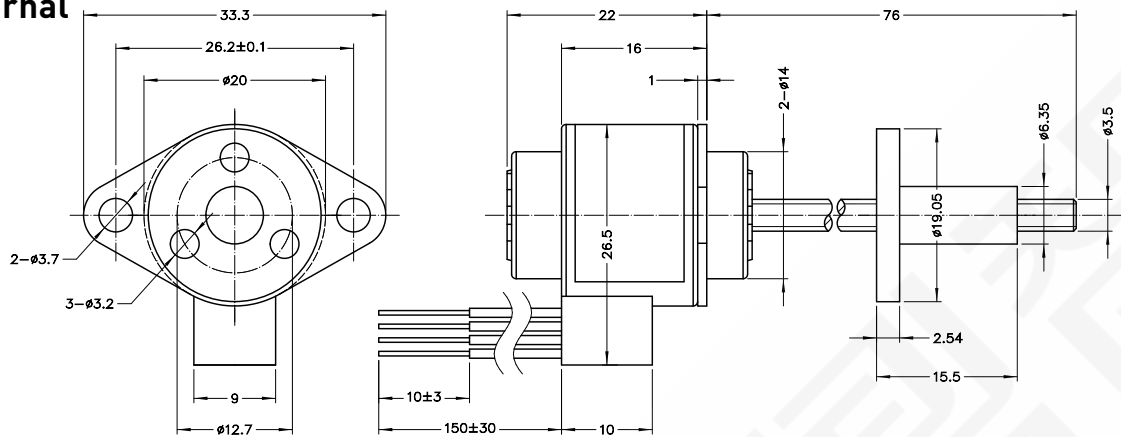

**2. Non-captive**

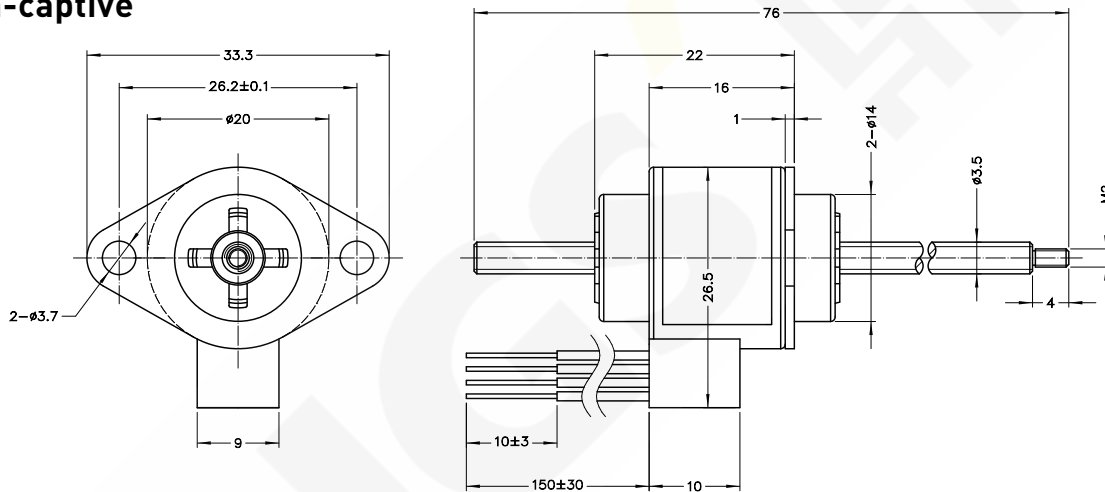

**3. Kaptive**

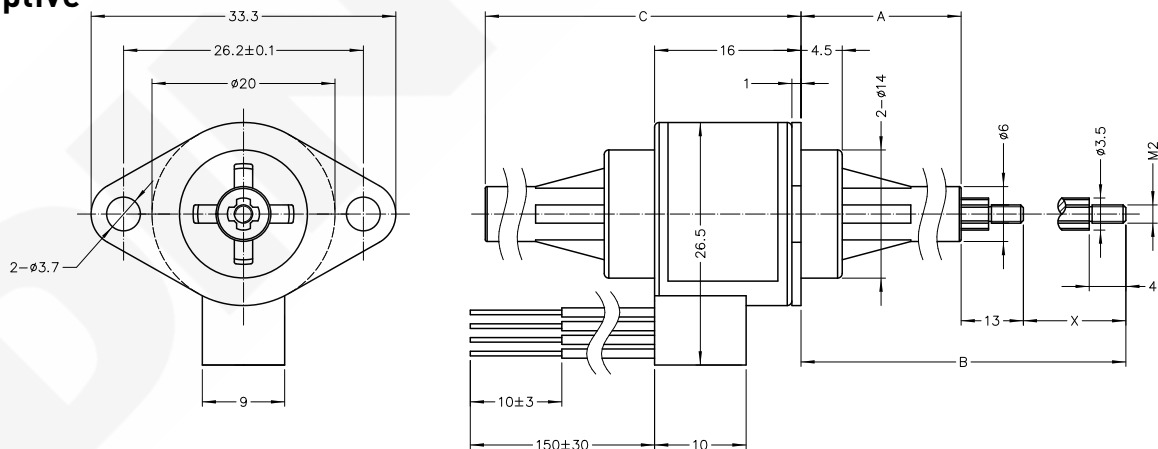

Stroke X	Front extension A	Total extension B	Body length C(MAX)
14	13.5±0.25	40.5±0.25	30.5
18	17.5±0.25	48.5±0.25	34.5
25	24.5±0.25	62.5±0.25	41.5
31	30.5±0.25	74.5±0.25	47.5

## 20 mm Series

### Linear Performance Curves

20 mm bi-polar, 5V/7.5° under 24 VDC chopper drive

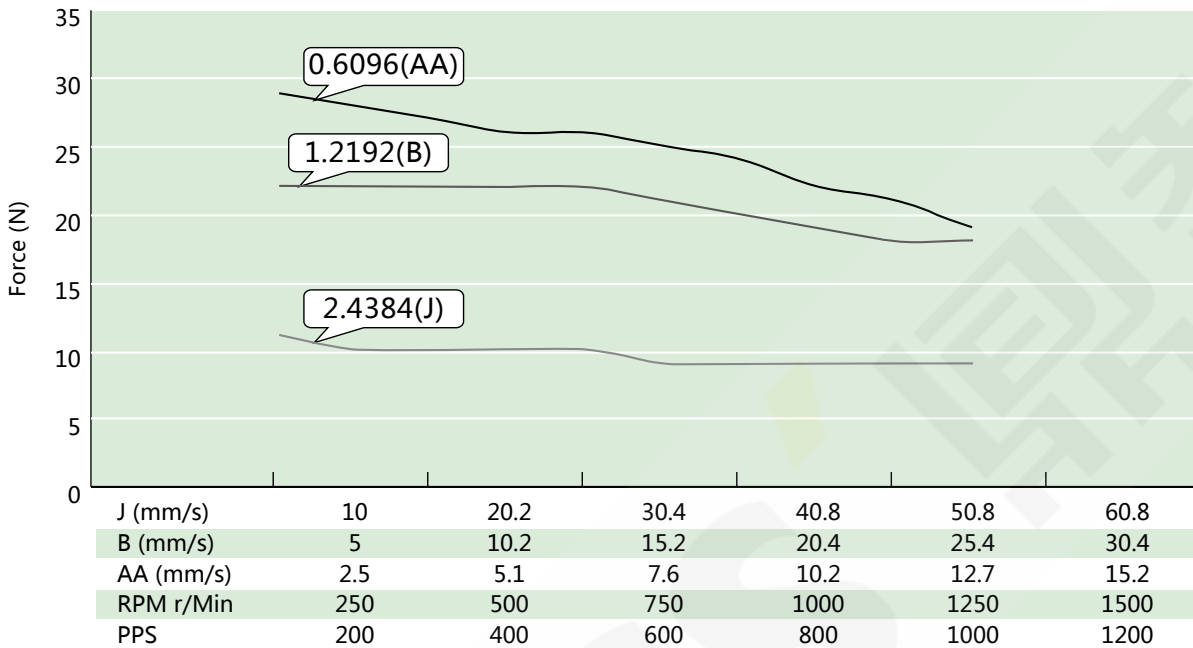

20 mm bi-polar, 12V/7.5° under 24 VDC chopper drive

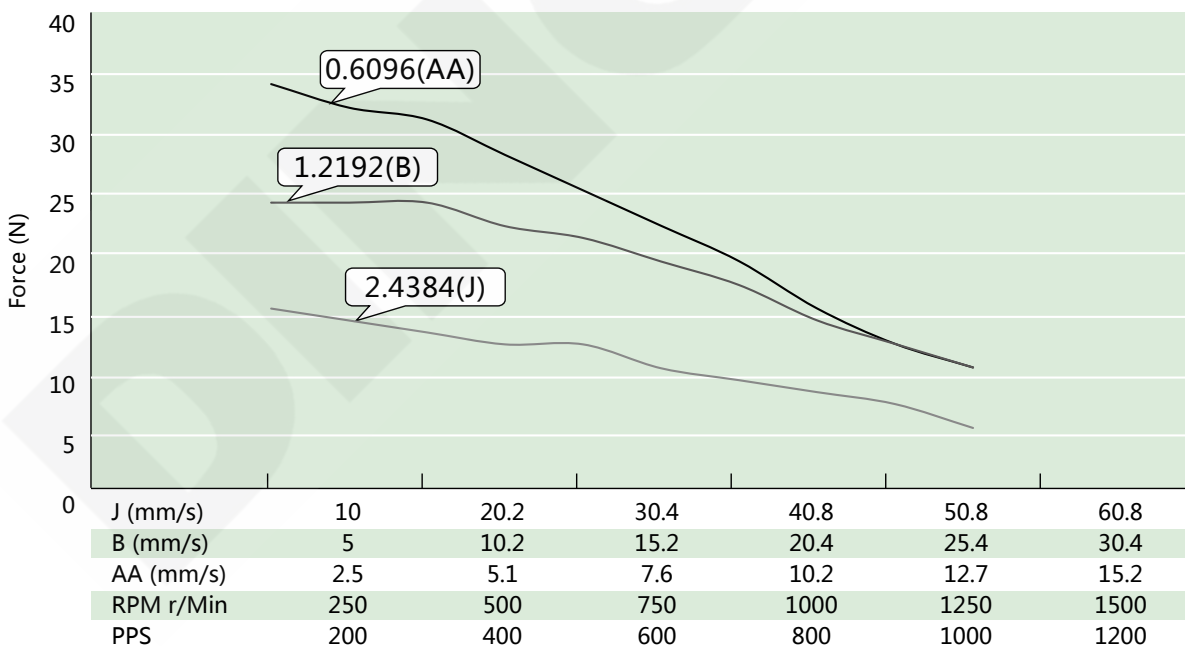



20 mm bi-polar, 5V/15° under 24 VDC chopper drive

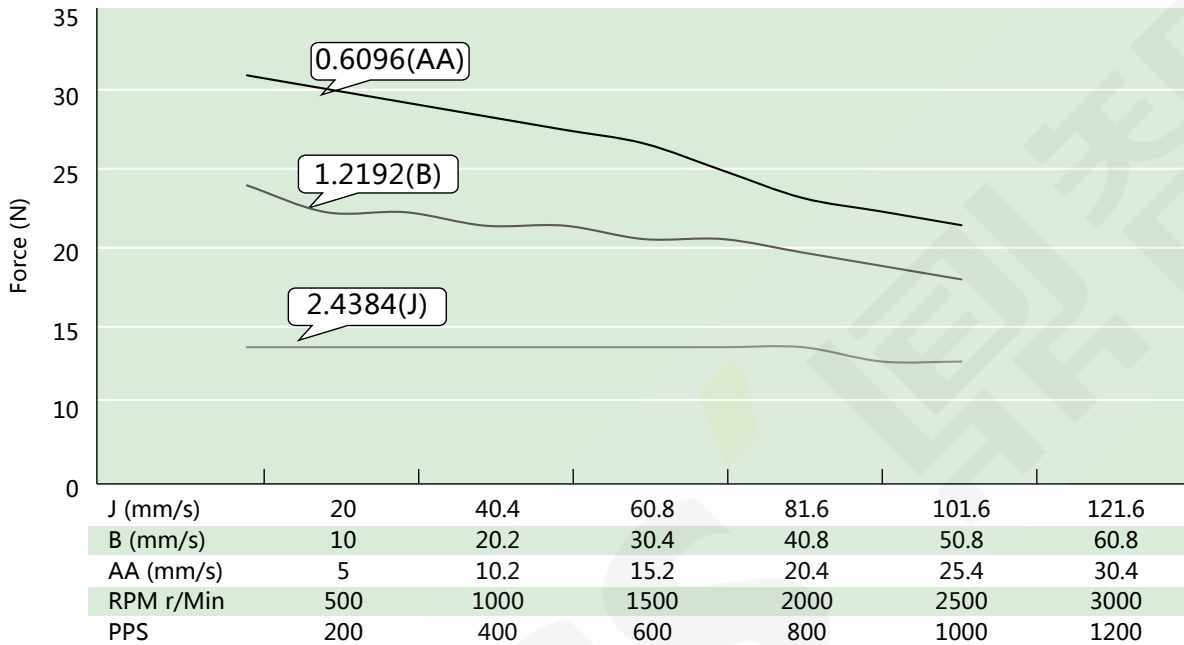

20 mm bi-polar, 12V/15° under 24 VDC chopper drive

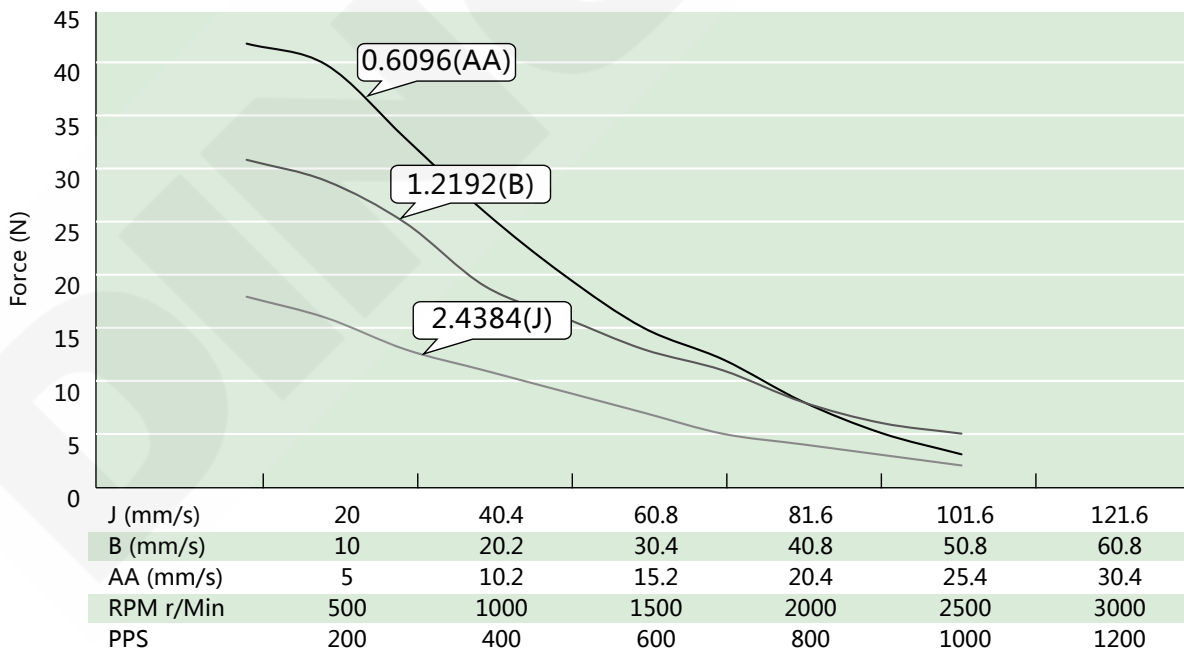

## 25 mm Series

### Parameters

[BACK TO](#)

25 mm frame				
<b>Polarity</b>	Bi-polar			
<b>Linear structure</b>	Kaptive, Non-captive, External			
<b>Step angle</b>	7.5°		15°	
<b>Winding</b>	5V	12V	5V	12V
<b>Phase Current</b>	370mA	160mA	370mA	160mA
<b>Phase resistance</b>	13.5Ω	70Ω	13.5Ω	70Ω
<b>Phase inductance</b>	15mH	75mH	11mH	55mH
<b>Power consumption</b>	3.85W			
<b>Rotor inertia</b>	1.08gcm <sup>2</sup>			
<b>Insulation class</b>	B			
<b>Insulation resistance</b>	100MΩ			
<b>Mass</b>	50g			

### Travel per Step and Screw Lead Code

Step angle	Screw lead		Travel per step		Screw lead code
	mm	inch	mm	inch	
7.5°	0.6096	0.024	0.0127	0.0005	AA
	1.2192	0.048	0.0254	0.0010	B
	2.4384	0.096	0.0508	0.0020	J
15°	0.6096	0.024	0.0254	0.0010	AA
	1.2192	0.048	0.0508	0.0020	B
	2.4384	0.096	0.1016	0.0040	J

**Dimensional Drawings**

**1. External**

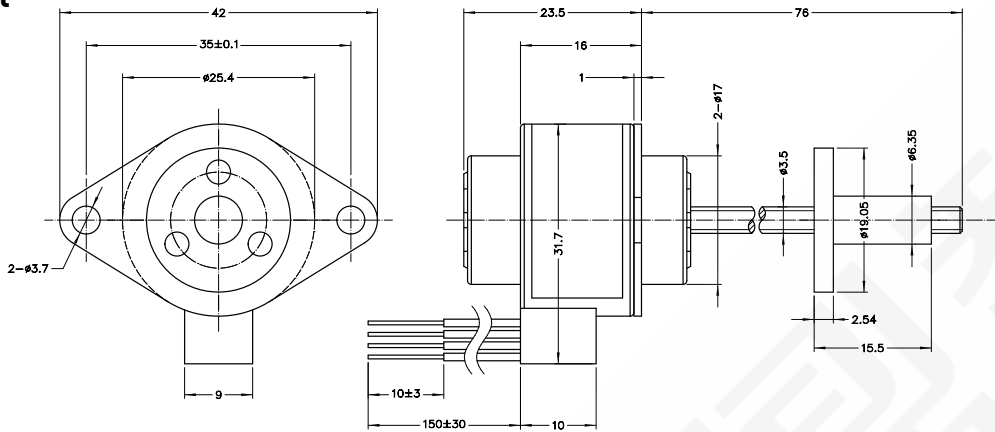

**2. Non-captive**

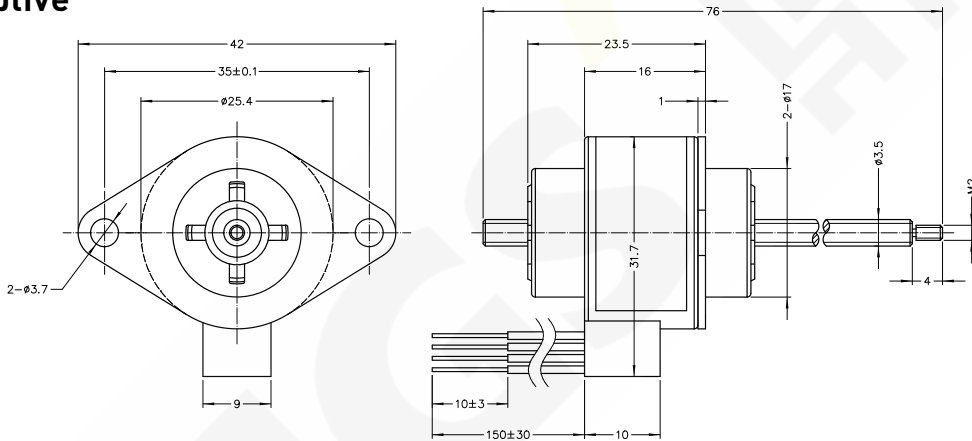

**3. Kaptive**

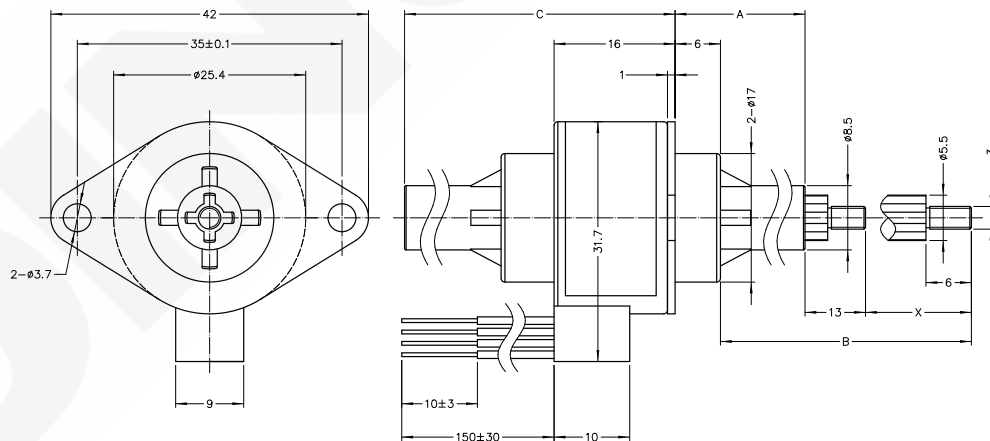

Stroke X	Front extension A	Total extension B	Body length C(MAX)
13	10.5±0.25	36.5±0.25	29.5
18	15.5±0.25	46.5±0.25	34.5
25	22.5±0.25	60.5±0.25	41.5
31	28.5±0.25	72.5±0.25	47.5

## 25 mm Series

### Linear Performance Curves

25 mm bi-polar, 5V/7.5° under 24 VDC chopper drive

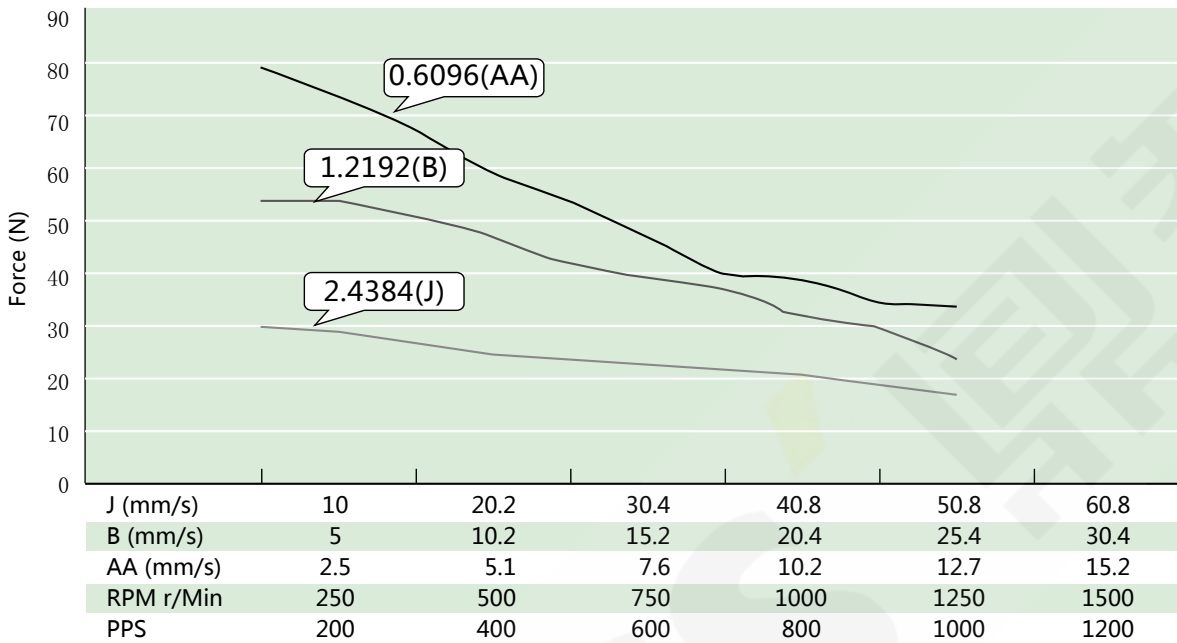

25 mm bi-polar, 12V/7.5° under 24 VDC chopper drive

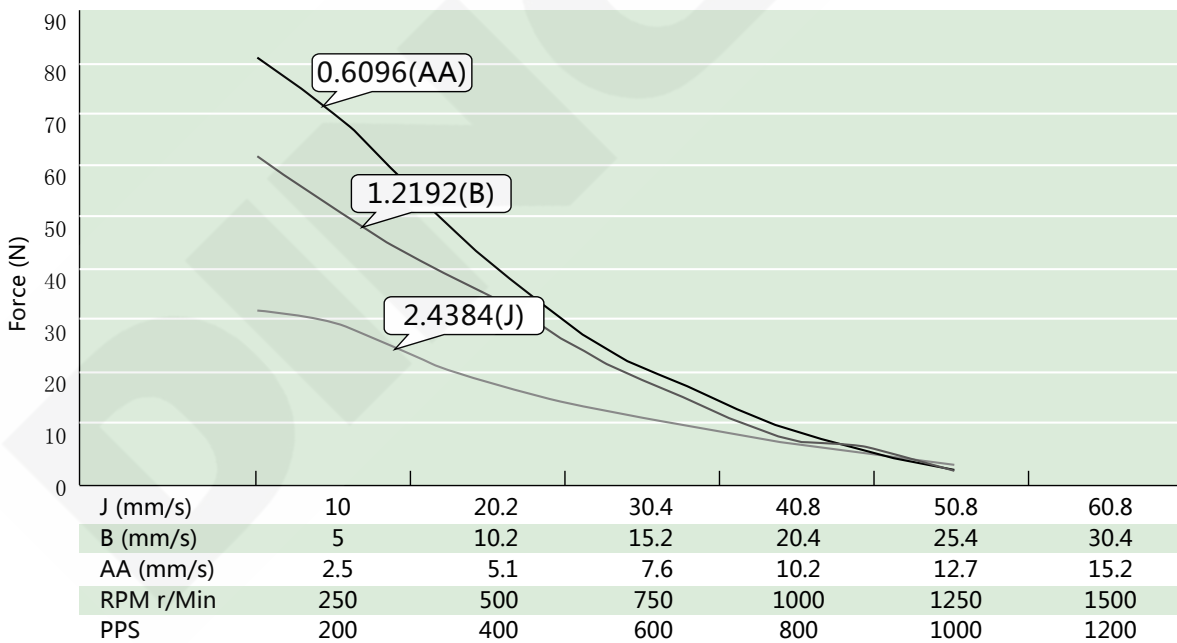

25 mm bi-polar, 5V/15° under 24 VDC chopper drive

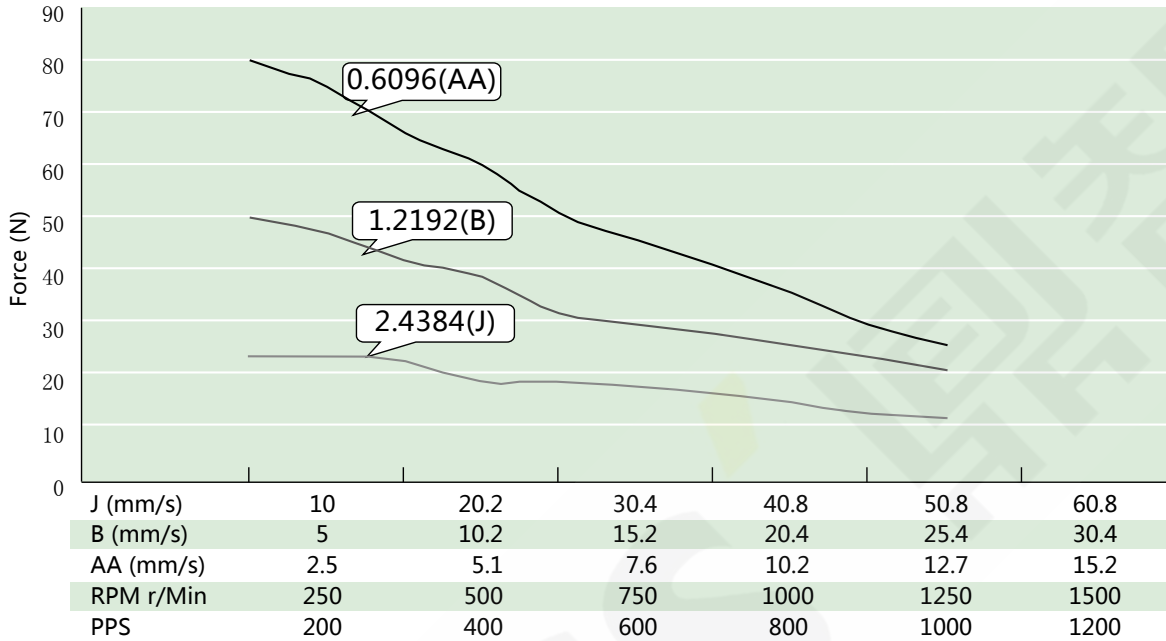

25 mm bi-polar, 12V/15° under 24 VDC chopper drive

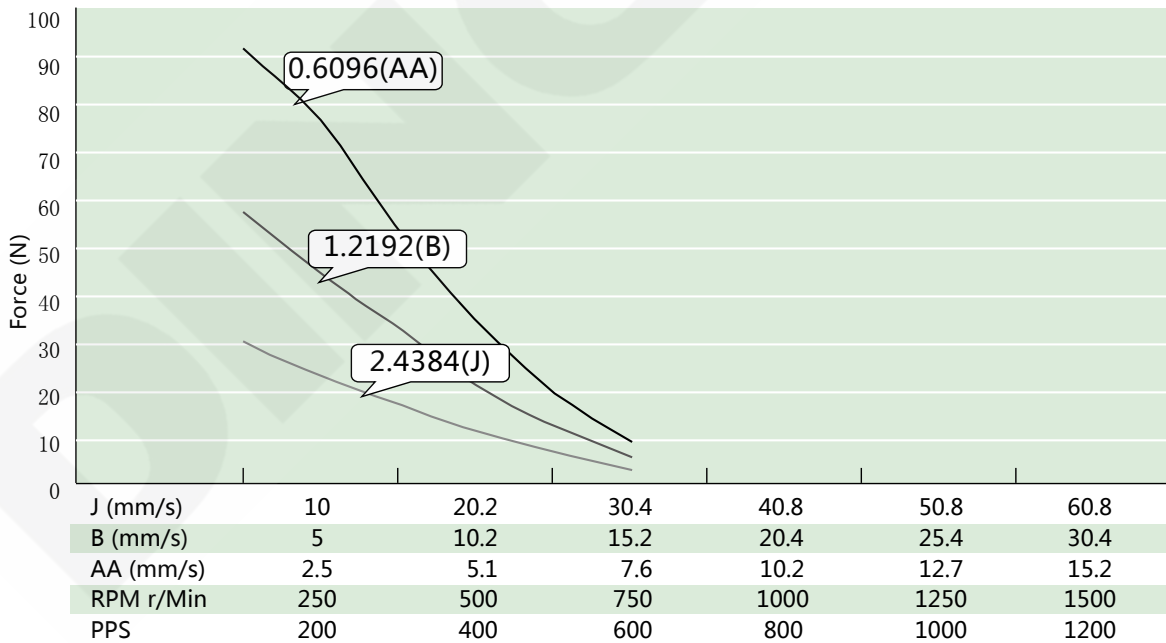



## 36 mm Series

## Parameters

BACK TO



Φ36mm电机				
<b>Polarity</b>	Bi-polar			
<b>Linear structure</b>	Kaptive, Non-captive, External			
<b>Step angle</b>	7.5°		15°	
<b>Winding</b>	5V	12V	5V	12V
<b>Phase Current</b>	560mA	230mA	560mA	230mA
<b>Phase resistance</b>	9Ω	52Ω	9Ω	52Ω
<b>Phase inductance</b>	13mH	85mH	9.5mH	62mH
<b>Power consumption</b>	5.6W			
<b>Rotor inertia</b>	8.5gcm <sup>2</sup>			
<b>Insulation class</b>	B			
<b>Insulation resistance</b>	100MΩ			
<b>Mass</b>	120g			

## Travel per Step and Screw Lead Code

Step angle	Screw lead		Travel per step		Screw lead code
	mm	inch	mm	inch	
7.5°	0.6096	0.024	0.0127	0.0005	AA
	1.2192	0.048	0.0254	0.0010	B
	2.4384	0.096	0.0508	0.0020	J
15°	0.6096	0.024	0.0254	0.0010	AA
	1.2192	0.048	0.0508	0.0020	B
	2.4384	0.096	0.1016	0.0040	J

**Dimensional Drawings**

**1. External**

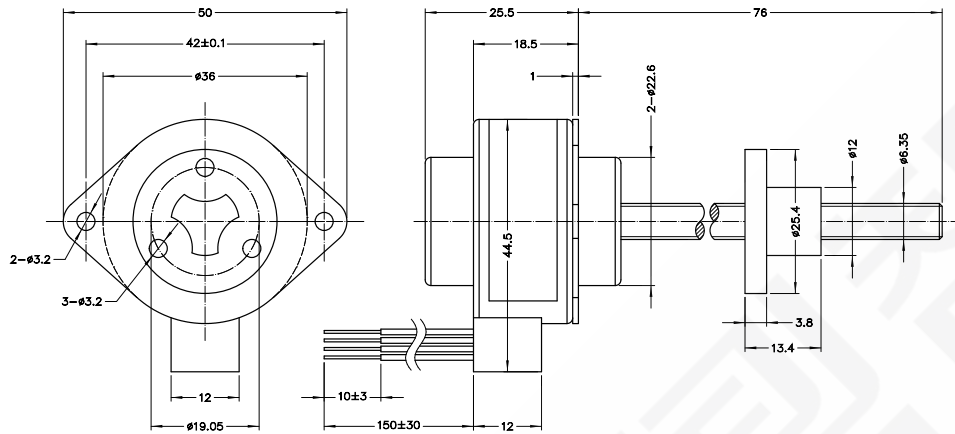

**2. Non-captive**

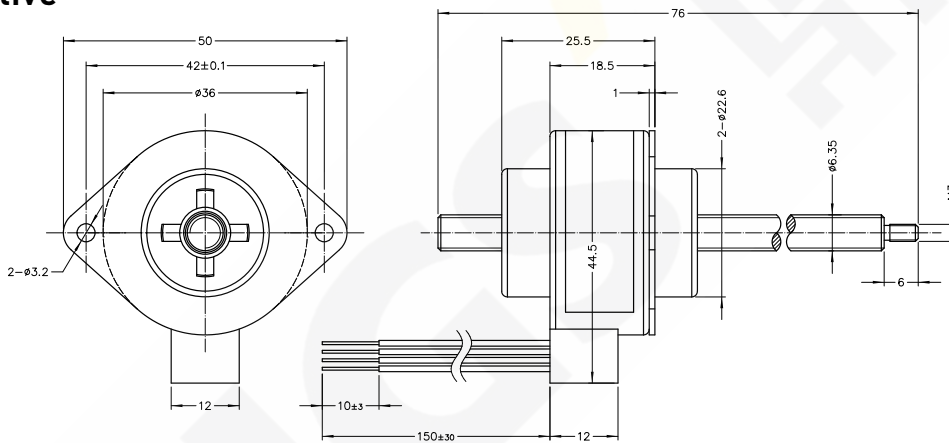

**3. Kaptive**

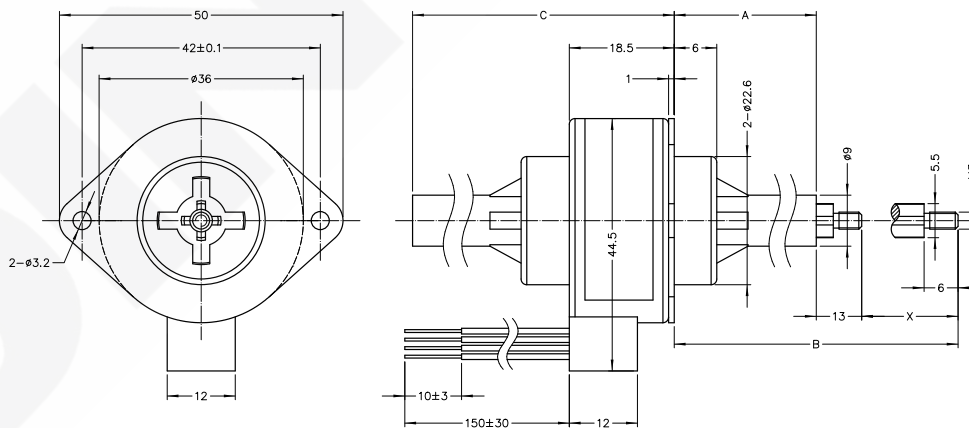

Stroke X	Front extension A	Total extension B	Body length C (MAX)
16	12±0.25	41±0.25	31.5
25	22±0.25	53±0.25	40.5
38	34±0.25	89±0.25	53.5

## 36 mm Series

### Linear Performance Curves

36 mm bi-polar, 5V/7.5° under 24 VDC chopper drive

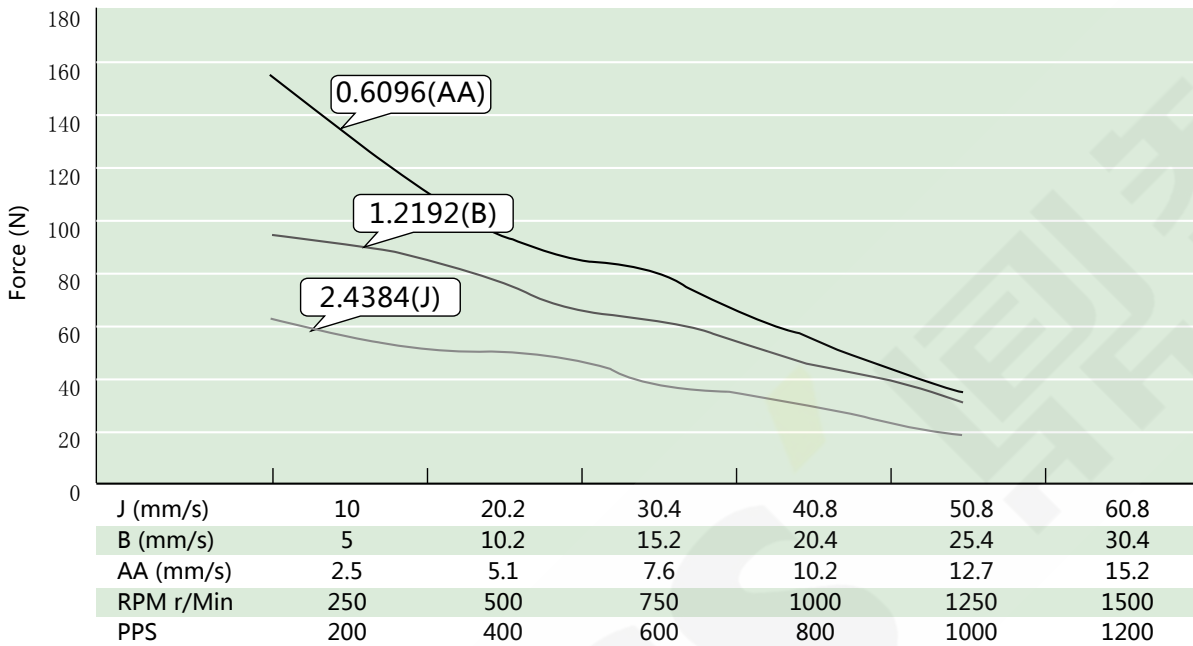

36 mm bi-polar, 5V/15° under 24 VDC chopper drive

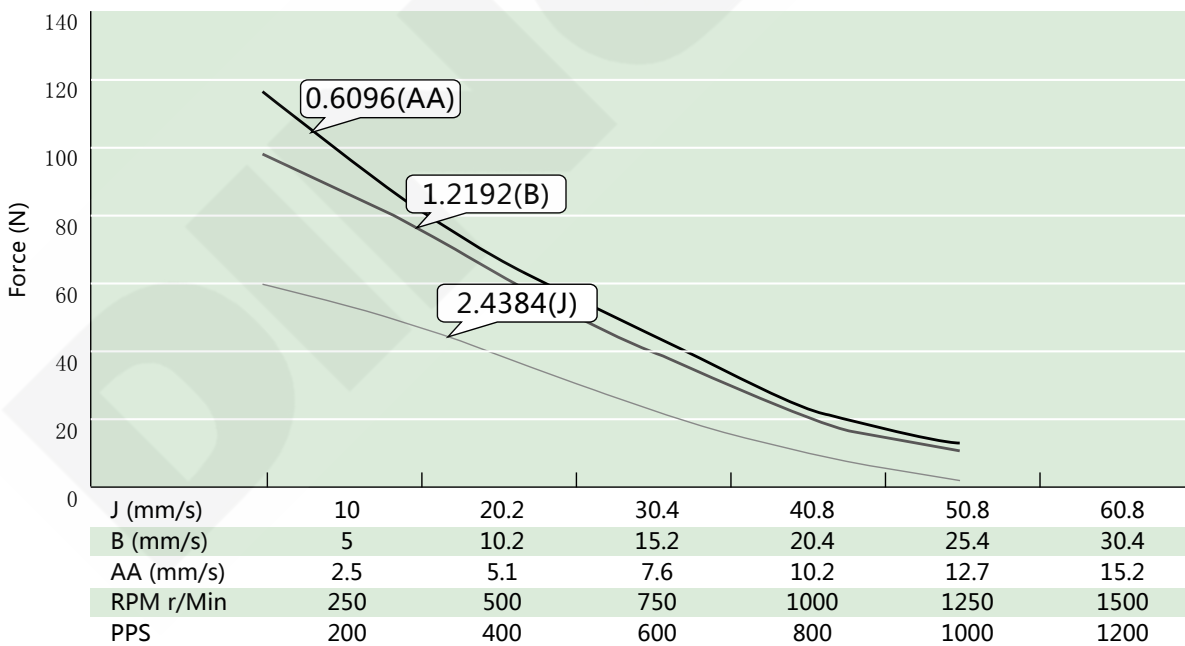

36 mm bi-polar, 12V/7.5° under 24 VDC chopper drive

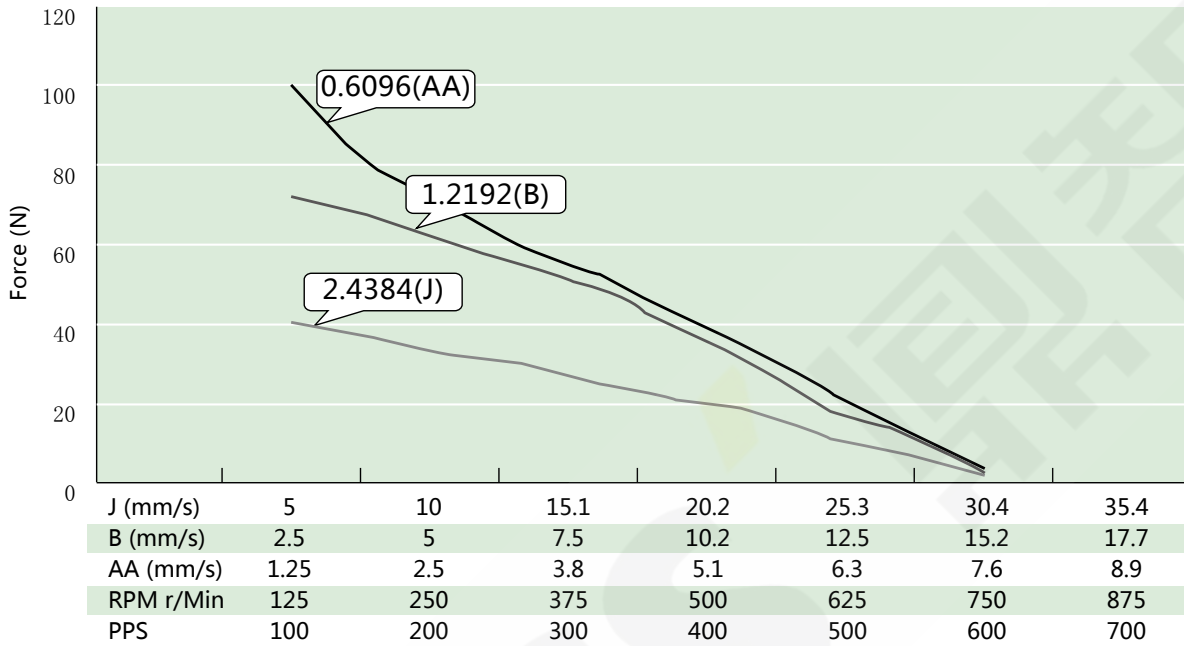

36 mm bi-polar, 12V/15° under 24 VDC chopper drive

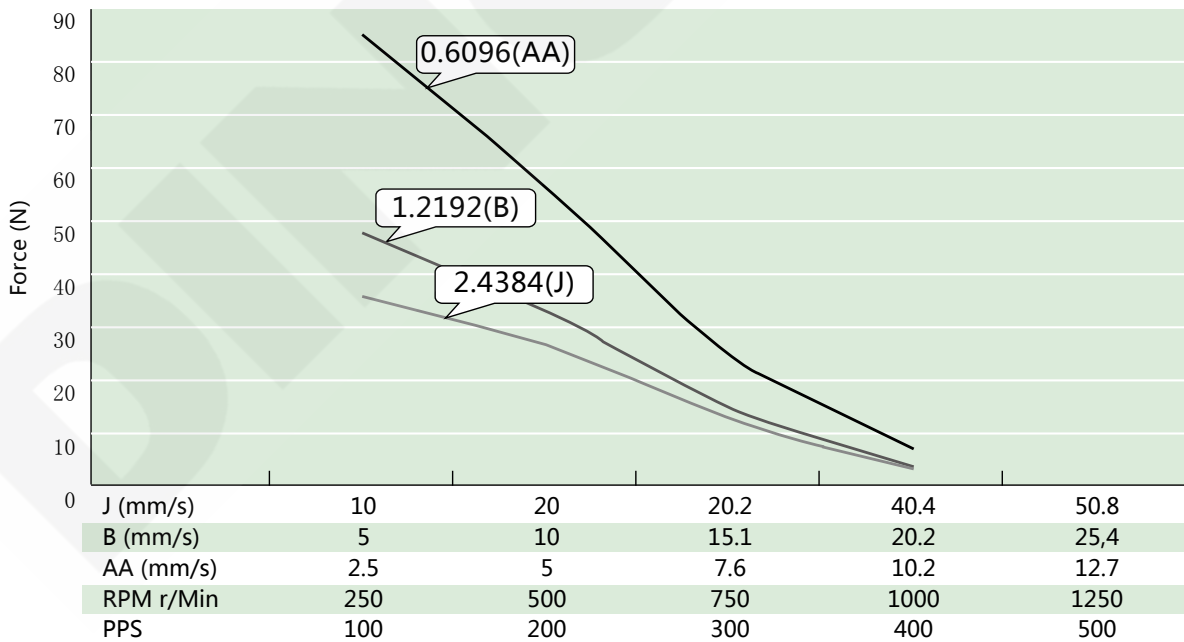

## B Hybrid rotary stepper motor

Dings' supply hybrid stepper motor of seven sizes - from 20 mm to 86 mm. Each size has different stack lengths. Planetary gearbox and encoder are available. For all motors Also special customization is available, such as special shaft, water proof and etc.

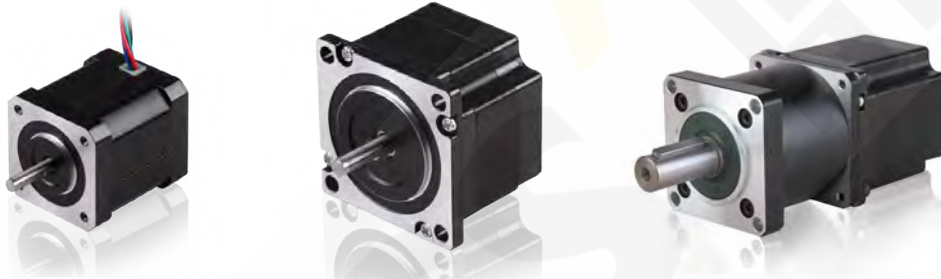

Part number construction	B-2
Product overview	B-3
Size 8 · 20 mm series	B-4
Size 11 · 28 mm series	B-6
Size 14 · 35 mm series	B-8
Size 17 · 42 mm series	B-10
Size 23 · 57 mm series	B-12
Size 24 · 60 mm series	B-14
Size 34 · 86 mm series	B-16
Accessories and options	B-18



## Part Number Construction

BACK TO

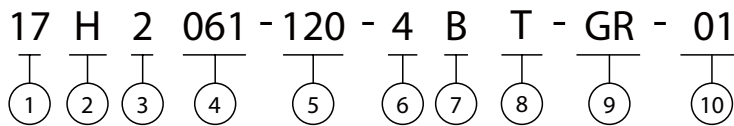

① Frame Size (mm)

CODE	08	11	14	17	23	24	34
MOTOR SIZE (mm)	20	28	35	42	57	60	86

② Basic Structure

- H = normal
- P = IP54
- W = Enhanced

③ Step Angle (°)

- 1 = 3
- 2 = 1.8
- 3 = 1.2
- 4 = 0.9
- 5 = 0.72

④ Body Length (truncated) (mm)

⑤ Rated Current×100 (A)

⑥ Wiring Number

⑦ Shaft Configuration

- A = single shaft
- B = dual shaft

⑧ Wiring Method

- L = discrete flying wire
- T = integrated connector
- C = cable

⑨ Option

- GR = planetary gearbox ready
- BR = brake ready
- ER = encoder ready
- PG = planetary gearbox
- FB = power off brake
- EK = encoder

⑩ Customer Sequence Number

### Example

**Naming code**

17H2061-120-4BT-GR-01

**Description**

Size 42 mm  
 Normal structure  
 Step angle 1.8°  
 Motor body length 61 mm  
 Rated current 1.2 A  
 Dual shaft  
 Wiring method integrated connector  
 Gearbox ready  
 4 wiring leads  
 Customization sequence code 01

**Product Overview****BACK TO**

Part number	current (A)	resistance ( $\Omega$ )	Inductance (mH)	Holding torque (N·m)	Rotorinertia (g·cm <sup>2</sup> )	motor length (mm)	Mass (g)
08H2028	0.5	5.1	1.5	0.014	2.7	28.5	60
08H2038	0.5	8.8	2.7	0.02	3.3	38	80
11H2032	1	2.1	1.5	0.06	9	33.5	110
11H2045	1	4.1	4.0	0.1	13	45	200
11H2052	1	4.7	4.6	0.14	18	52	280
14H2027	0.5	20	23	0.15	19	28	100
14H2033	1	4	6	0.18	24	34	140
14H2037	1.5	2	3.2	0.2	28	38	180
17H2034	0.5	15	21	0.25	25	34	230
17H2041	1	4	8	0.4	54	41	300
17H2049	1.5	2	3.85	0.48	77	49	360
17H2061	2	1.8	3.7	0.72	110	61	500
23H2042	1	4.2	11	0.6	140	42.5	460
23H2051	2	1.5	4.4	1	240	51.5	640
23H2065	3	0.9	3.6	1.7	350	65.5	860
23H2076	4	0.6	2.4	2	480	76.5	1060
24H2047	2	1.5	3.9	0.9	240	47	600
24H2056	3	0.8	3	1.3	340	56	800
24H2068	4	0.6	2.5	2.2	490	68	1000
24H2085	5	0.4	1.8	2.5	690	85	1300
34H2060	3	1	6	2.6	1100	60.5	1600
34H2075	4.5	0.6	6	4.5	1800	75	2100
34H2098	6	0.5	5.5	7.2	2800	98	2900

**Dimensional Drawing**

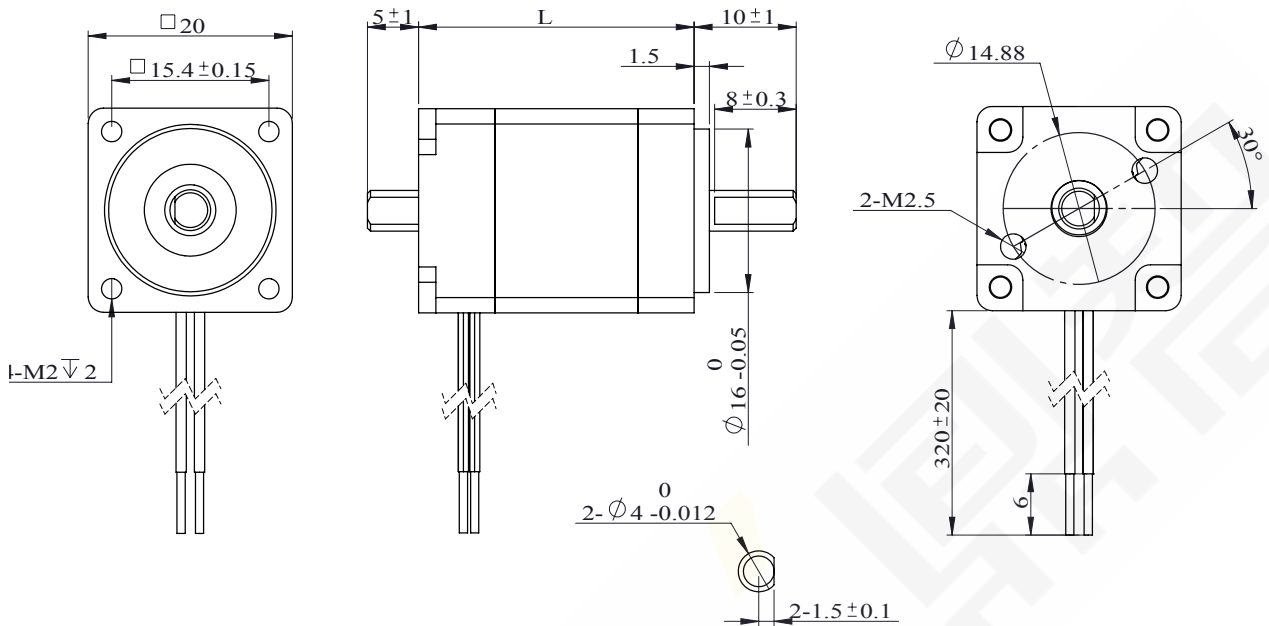

**Parameters**

General							
Accuracy	Step angle		1.8°±5%				
	Resistance		±10% / 20 C				
	Inductance		±20% / 1KHz				
Insulation class			B				
Duty type			S1				
Dielectrical strength			500 VAC / 1 KHz / 1 mA / 1 s				
Insulation resistance			100 MΩ / 500 VDC				
Parameter							
Type	Current (A)	Resistance (Ω)	Inductance (mH)	Holding Torque (N·m)	Rotor Inertia (g·cm <sup>2</sup> )	Length (mm)	Mass (g)
08H2028	0.5	5.1	1.5	0.014	2.7	27.2	60
08H2038	0.5	8.8	2.7	0.02	3.3	38	80
Material							
End bell			Aluminum alloy				
Bearing			Deep groove ball bearing				
Magnet			Sintered NdFeB				
Shaft			Stainless steel				
Wiring			UL 3265, 28 AWG				

## Size 8 (20 mm) Series

### ■ Torque Performance Curves

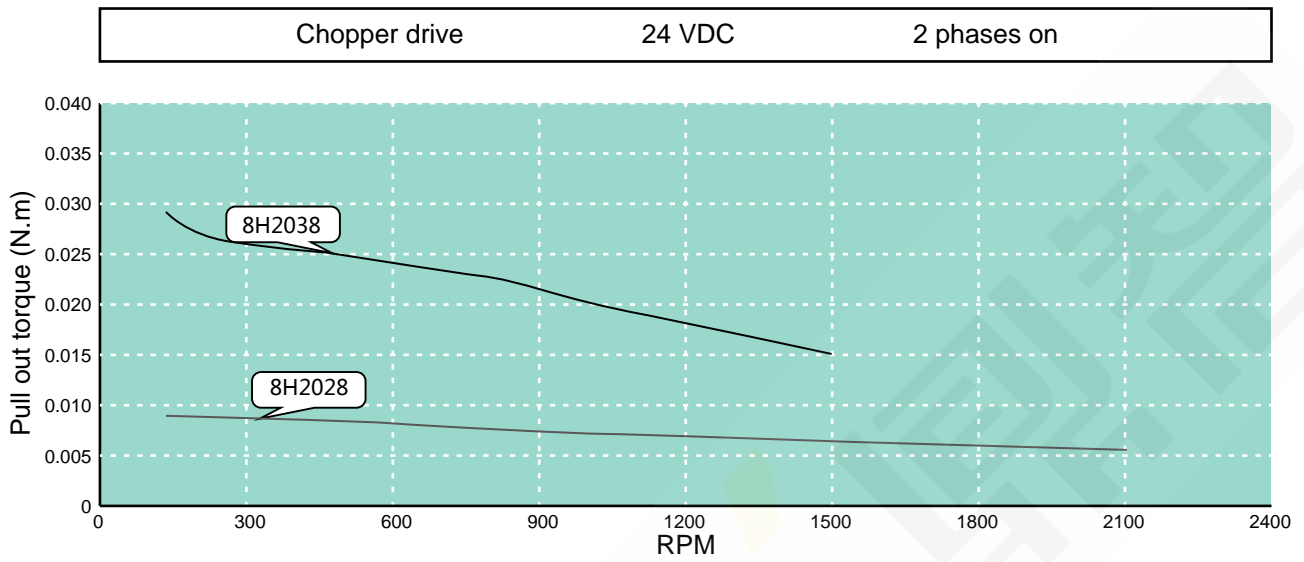

### Dimensional Drawing

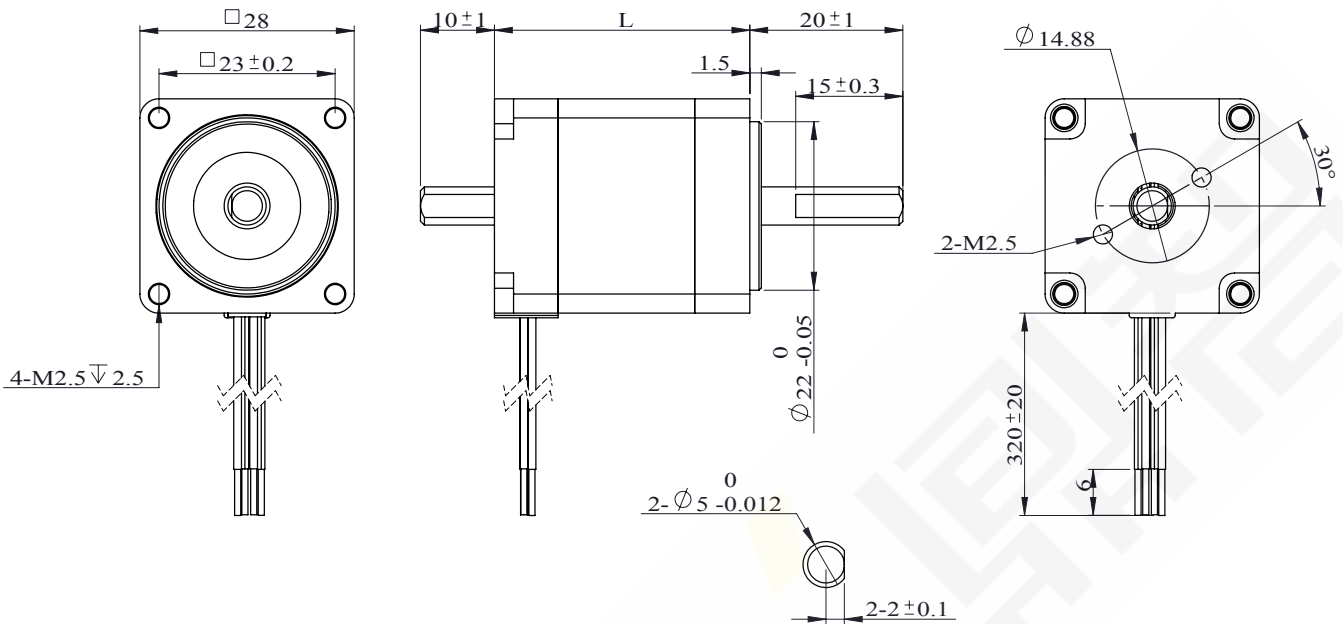

### Parameters

General							
Accuracy	Step angle		1.8°±5%				
	Resistance		±10% / 20 C				
	Inductance		±20% / 1KHz				
Insulation class			B				
Duty type			S1				
Dielectrical strength			500 VAC / 1 KHz / 1 mA / 1 s				
Insulation resistance			100 MΩ / 500 VDC				
Parameter							
Type	Current (A)	Resistance (Ω)	Inductance (mH)	Holding Torque (N·m)	Rotor Inertia (g·cm <sup>2</sup> )	Length (mm)	Mass (g)
11H2032	1	2.1	1.5	0.06	9	33.5	110
11H2045	1	4.1	4.0	0.1	13	45	200
11H2052	1	4.7	4.6	0.14	18	52	280
Material							
End bell			Aluminum alloy				
Bearing			Deep groove ball bearing				
Magnet			Sintered NdFeB				
Shaft			Stainless steel				
Wiring			UL 3265, 26 AWG				



## Size 11 (28 mm) Series

### ■ Torque Performance Curves

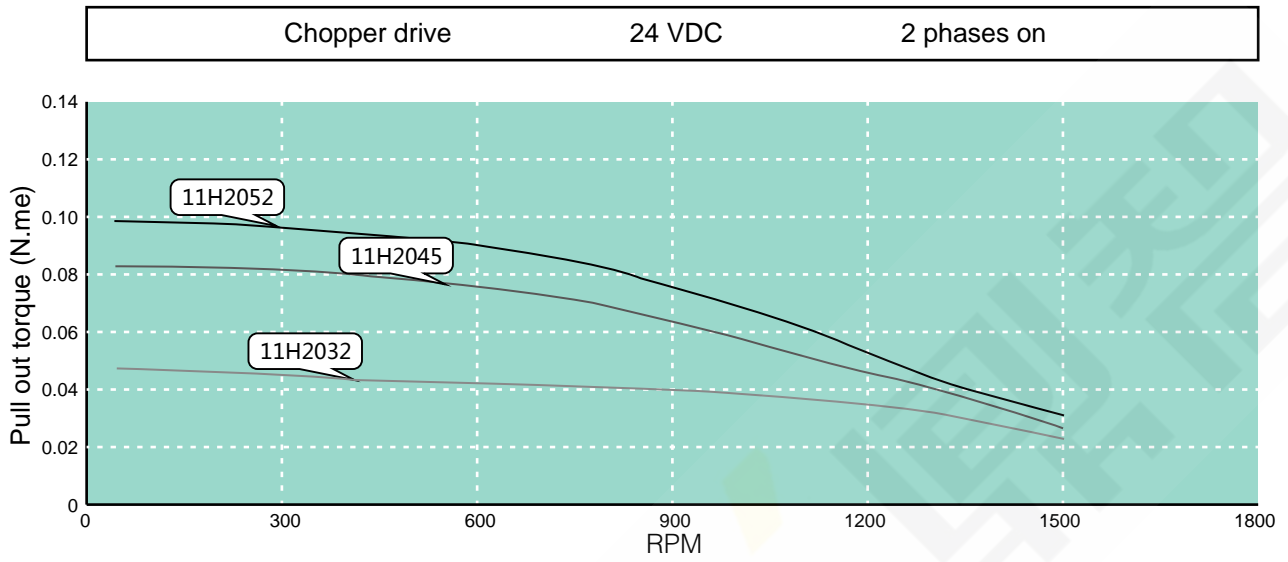

### Dimensional Drawing

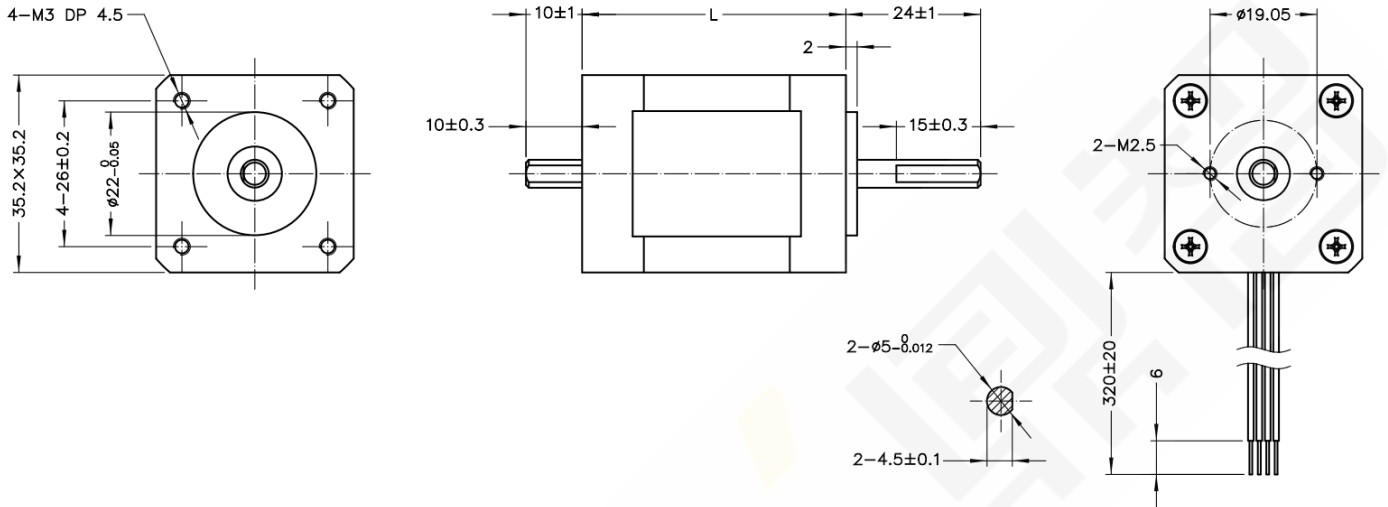

### Parameters

General							
Accuracy	Step angle		1.8°±5%				
	Resistance		±10% / 20 C				
	Inductance		±20% / 1KHz				
Insulation class			B				
Duty type			S1				
Dielectrical strength			500 VAC / 1 KHz / 1 mA / 1 s				
Insulation resistance			100 MΩ / 500 VDC				
Parameter							
Type	Current (A)	Resistance (Ω)	Inductance (mH)	Holding Torque (N·m)	Rotor Inertia (g·cm <sup>2</sup> )	Length (mm)	Mass (g)
14H2027	0.5	20	23	0.15	19	28	100
14H2033	1	4	6	0.18	24	34	140
14H2037	1.5	2	3.2	0.2	28	38	180
Material							
End bell			Aluminum alloy				
Bearing			Deep groove ball bearing				
Magnet			Sintered NdFeB				
Shaft			Stainless steel				
Wiring			UL 3265, 26 AWG				

## Size 14 (35 mm) Series

### ■ Torque Performance Curves

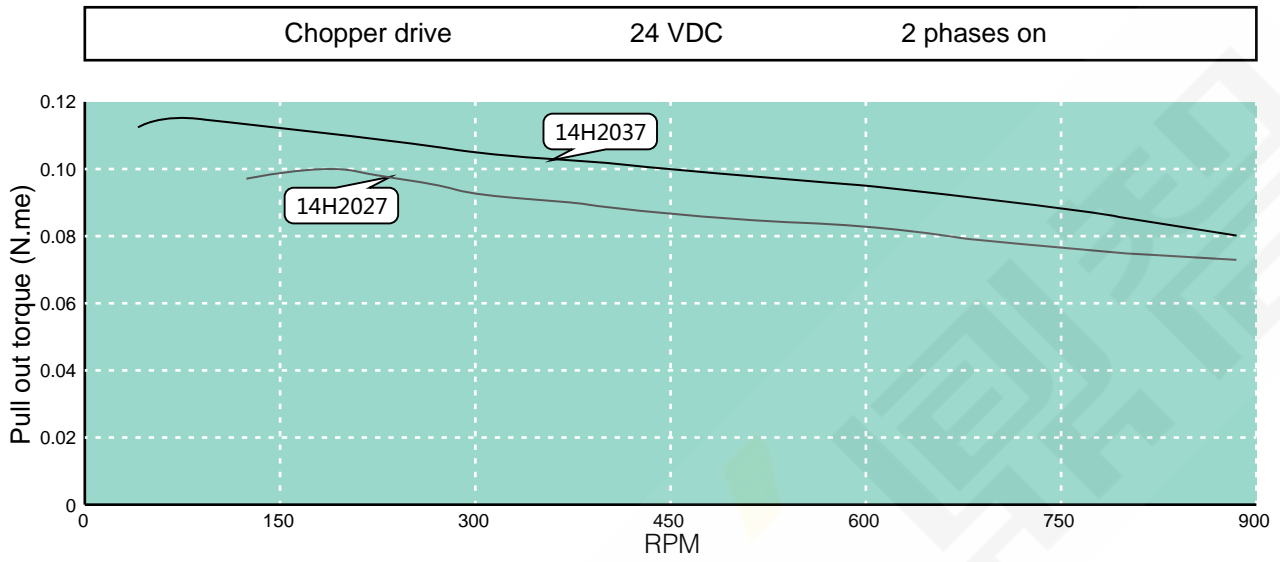

**Dimensional Drawing**

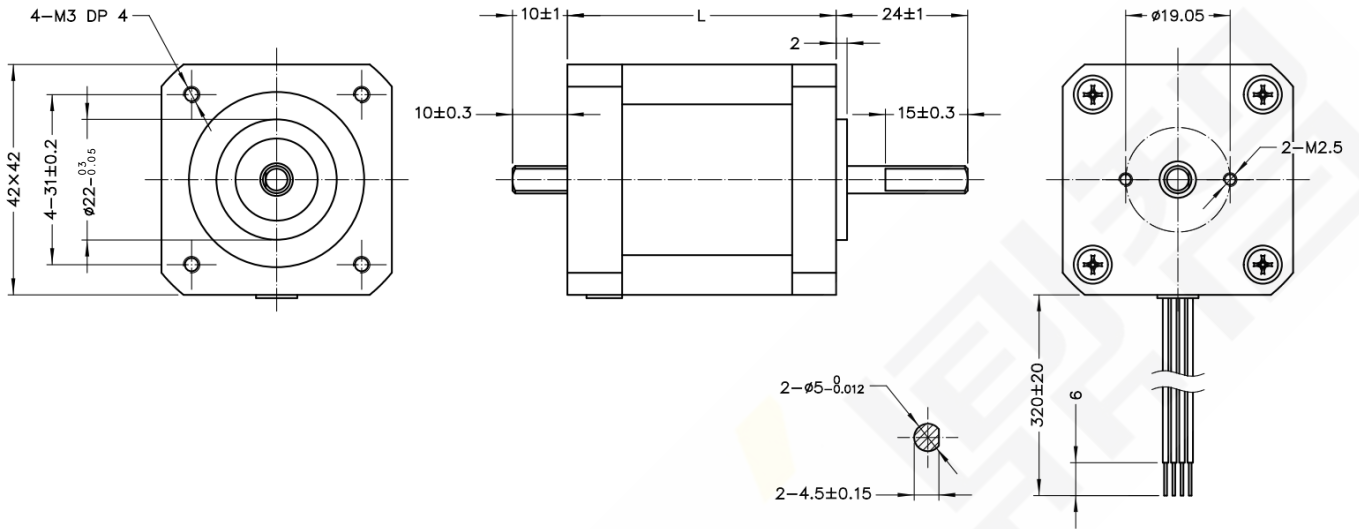

**Parameters**

General							
Accuracy	Step angle		1.8°±5%				
	Resistance		±10% / 20 C				
	Inductance		±20% / 1KHz				
Insulation class			B				
Duty type			S1				
Dielectrical strength			500 VAC / 1 KHz / 1 mA / 1 s				
Insulation resistance			100 MΩ / 500 VDC				
Parameter							
Type	Current (A)	Resistance (Ω)	Inductance (mH)	Holding Torque (N·m)	Rotor Inertia (g·cm <sup>2</sup> )	Length (mm)	Mass (g)
17H2034	0.5	15	21	0.25	25	34	230
17H2041	1	4	8	0.4	54	41	300
17H2049	1.5	2	3.85	0.48	77	49	360
17H2061	2	1.8	3.7	0.72	110	61	500
Material							
End bell			Aluminum alloy				
Bearing			Deep groove ball bearing				
Magnet			Sintered NdFeB				
Shaft			Stainless steel				
Wiring			UL 3265, 28 AWG				

## Size 17 (42 mm) Series

### ■ Torque Performance Curves

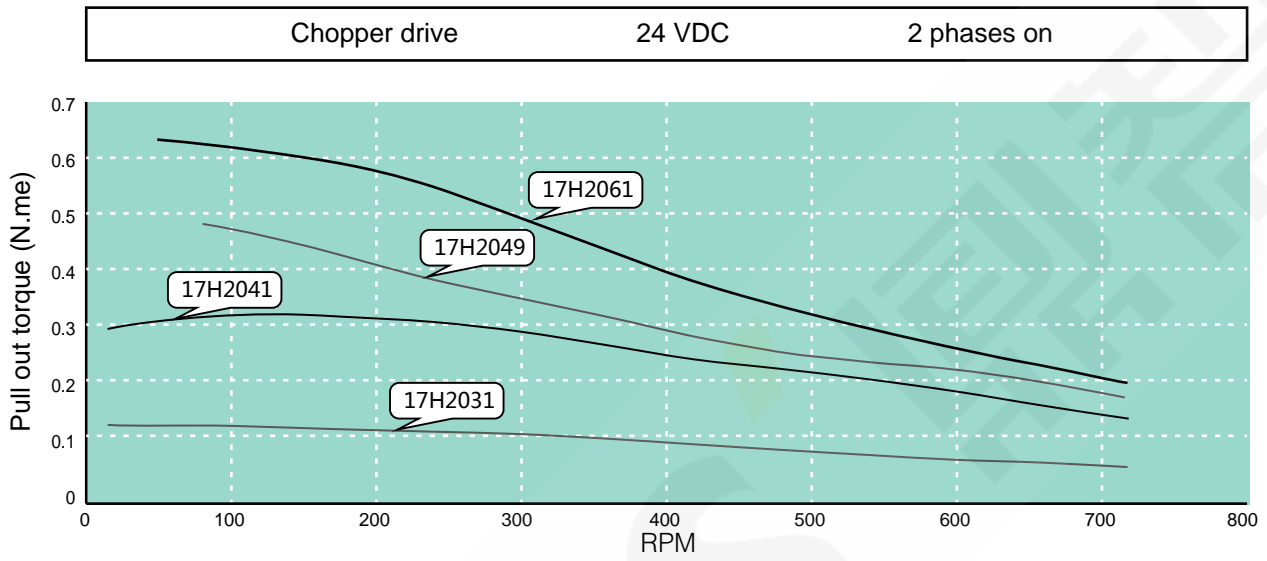



### Dimensional Drawing

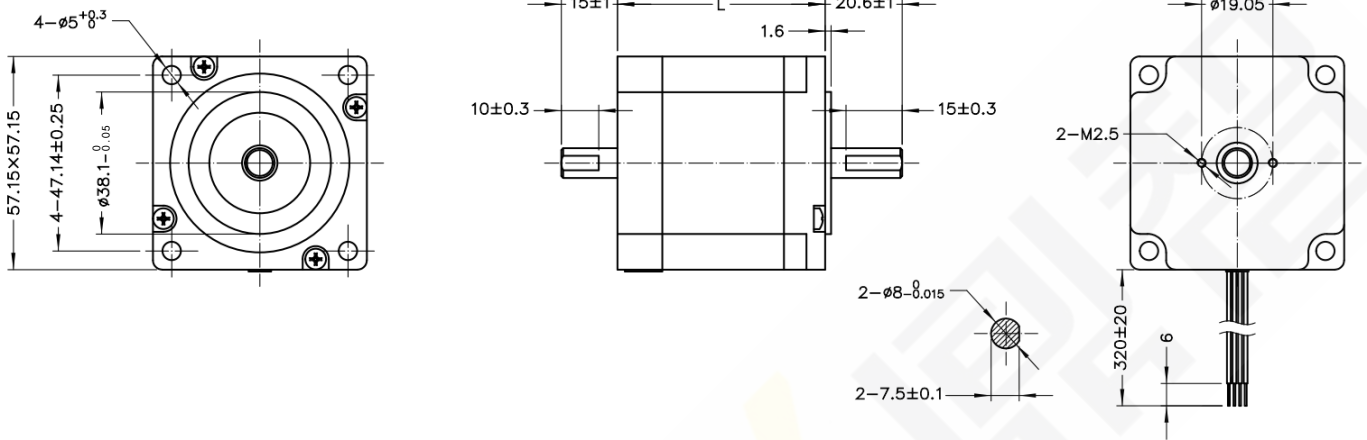

### Parameters

General							
Accuracy	Step angle		1.8°±5%				
	Resistance		±10% / 20 C				
	Inductance		±20% / 1KHz				
Insulation class			B				
Duty type			S1				
Dielectrical strength			500 VAC / 1 KHz / 1 mA / 1 s				
Insulation resistance			100 MΩ / 500 VDC				
Parameter							
Type	Current (A)	Resistance (Ω)	Inductance (mH)	Holding Torque (N·m)	Rotor Inertia (g·cm <sup>2</sup> )	Length (mm)	Mass (g)
23H2042	1	4.2	11	0.6	140	42.5	460
23H2051	2	1.5	4.4	1	240	51.5	640
23H2065	3	0.9	3.6	1.7	350	65.5	860
23H2076	4	0.6	2.4	2	480	76.5	1060
Material							
End bell			Aluminum alloy				
Bearing			Deep groove ball bearing				
Magnet			Sintered NdFeB				
Shaft			Stainless steel				
Wiring			UL 3265, 22 AWG				

## Size 23 (57 mm) Series

### ■ Torque Performance Curves

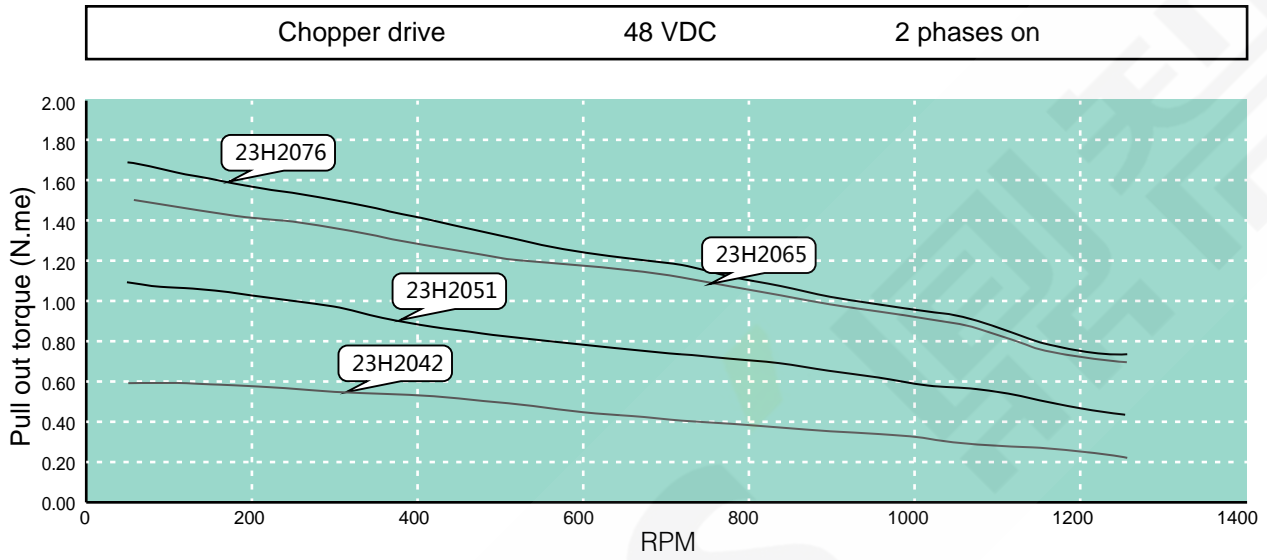

### Dimensional Drawing

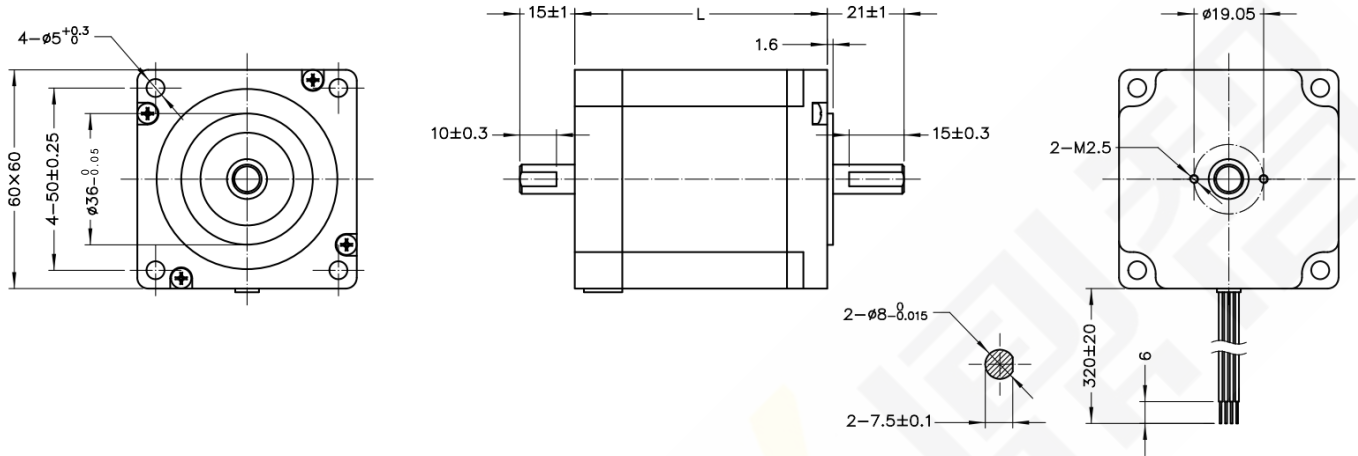

### Parameters

General							
Accuracy	Step angle		1.8°±5%				
	Resistance		±10% / 20 C				
	Inductance		±20% / 1KHz				
Insulation class			B				
Duty type			S1				
Dielectrical strength			500 VAC / 1 KHz / 1 mA / 1 s				
Insulation resistance			100 MΩ / 500 VDC				
Parameter							
Type	Current (A)	Resistance (Ω)	Inductance (mH)	Holding Torque (N·m)	Rotor Inertia (g·cm <sup>2</sup> )	Length (mm)	Mass (g)
24H2047	2	1.5	3.9	0.9	240	47	600
24H2056	3	0.8	3	1.3	340	56	800
24H2068	4	0.6	2.5	2.2	490	68	1000
24H2085	5	0.4	1.8	2.5	690	85	1300
Material							
End bell			Aluminum alloy				
Bearing			Deep groove ball bearing				
Magnet			Sintered NdFeB				
Shaft			Stainless steel				
Wiring			UL 3265, 20 AWG				

## Size 24 (60 mm) Series

### ■ Torque Performance Curves

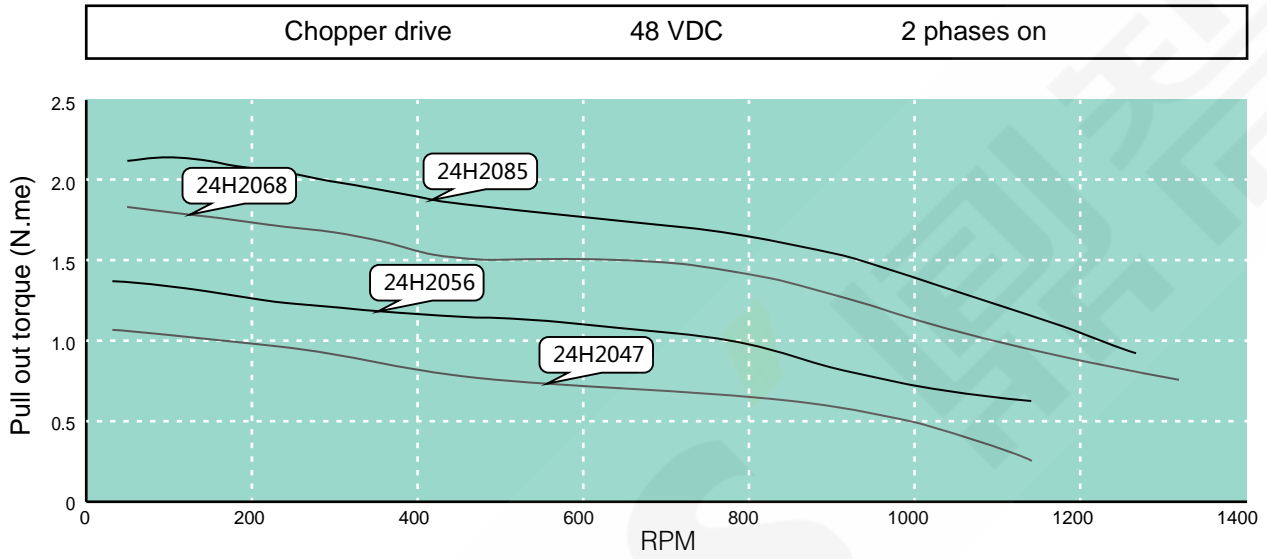

### Dimensional Drawing

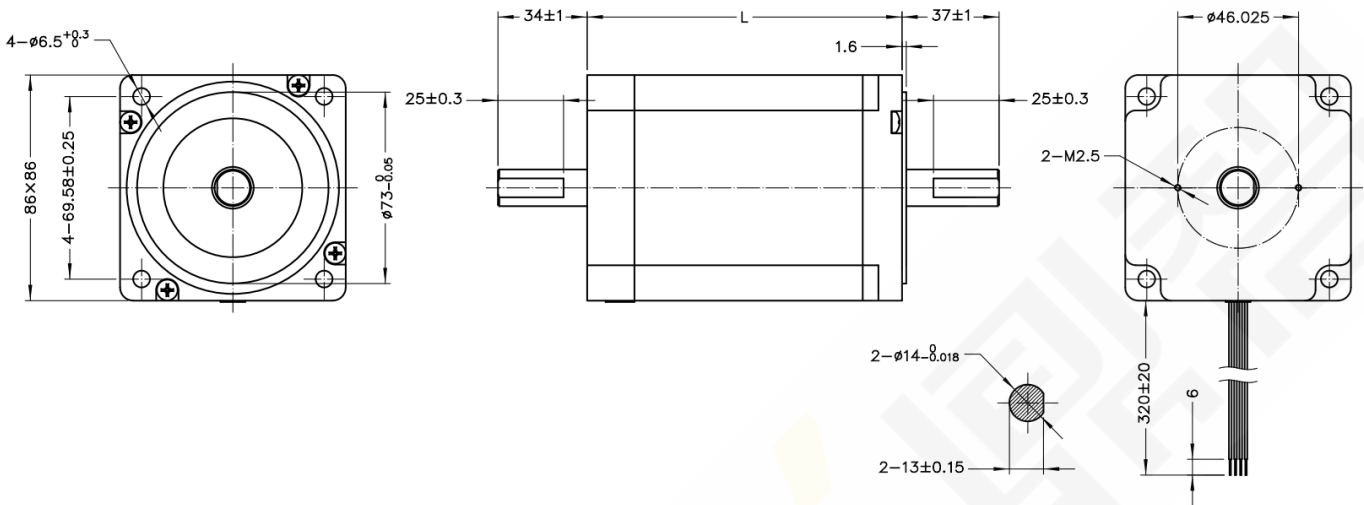

### Parameters

General							
Accuracy	Step angle		1.8°±5%				
	Resistance		±10% / 20 C				
	Inductance		±20% / 1KHz				
Insulation class			B				
Duty type			S1				
Dielectrical strength			500 VAC / 1 KHz / 1 mA / 1 s				
Insulation resistance			100 MΩ / 500 VDC				
Parameter							
Type	Current (A)	Resistance (Ω)	Inductance (mH)	Holding Torque (N·m)	Rotor Inertia (g·cm <sup>2</sup> )	Length (mm)	Mass (g)
34H2060	3	1	6	2.6	1100	60.5	1600
34H2075	4.5	0.6	6	4.5	1800	75	2100
34H2098	6	0.5	5.5	7.2	2800	98	2900
Material							
End bell			Aluminum alloy				
Bearing			Deep groove ball bearing				
Magnet			Sintered NdFeB				
Shaft			Stainless steel				
Wiring			UL 3265, 18 AWG				



## Size 34 (86 mm) Series

### ■ Torque Performance Curves

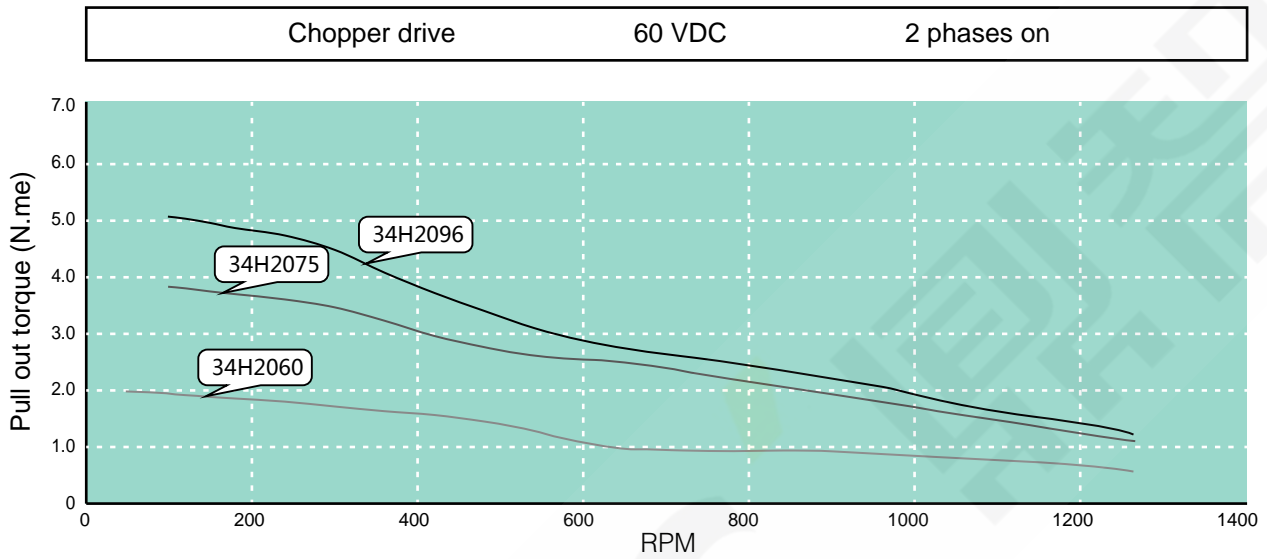

BACK TO

### Planetary Gearbox

#### Overview

Frame size	Ratio	Rated torque (Kgf-cm)	Limit torque (Kgf-cm)	Stages	Efficiency (%)	Length (mm)	Mass (g)	Corresponding motor
22 mm	4	0.3	0.9	1	81	16.3	29.1	20 mm
	15	0.5	1.5	2	66	16.3	30.1	
	20							
	107	1	3	3	53	19.5	36	
28 mm	3.3	5	15	1	90	21.2	87	28 mm
	4.6							
	11.2	10	30	2	81	26.9	91	
	15.5							
	21.5							
	37.7	25	75	3	73	32.7	100	
72								
32 mm	3.3	5	15	1	90	16.2	90	35 mm
	4.6							
	11.2	10	30	2	81	21.9	115	
	15.5							
	21.5							
	37.7	25	75	3	73	27.7	140	
72								
42 mm	3.7	10	30	1	90	30.6	260	42 mm
	5.2							
	13.7	20	60	2	81	41.9	350	
	19.2							
	26.9							
	50.9	50	150	3	73	53.2	440	
	71.2							
99.5								
57 mm	5	60	120	1	95	53	800	57 mm
	10							
	15	250	400	2	90	70	1100	
	20							
	25							
60 mm	5	60	120	1	95	53	900	60 mm
	10							
	15	250	400	2	90	70	1200	
	20							
	25							

## Accessories and Options

- 22 mm Frame Planetary Gearbox
- Dimensional Drawing

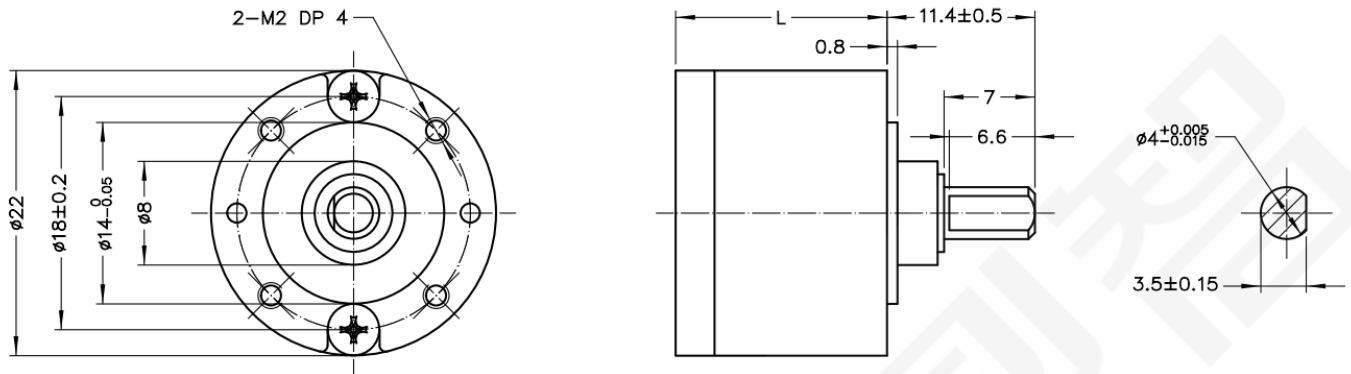

## Parameters

House material			Metal			
No load backlash			1°			
Bearing			Sleeve bearing			
Ratio	Rated torque (Kgf-cm)	Limit torque (Kgf-cm)	Stages	Efficiency (%)	Length (mm)	Mass (g)
4	0.3	0.9	1	81	16.3	29.1
15	0.5	1.5	2	66	16.3	30.1
20						
107	1	3	3	53	19.5	36

## Accessories and Options

- 28 mm Frame Planetary Gearbox
- Dimensional Drawing

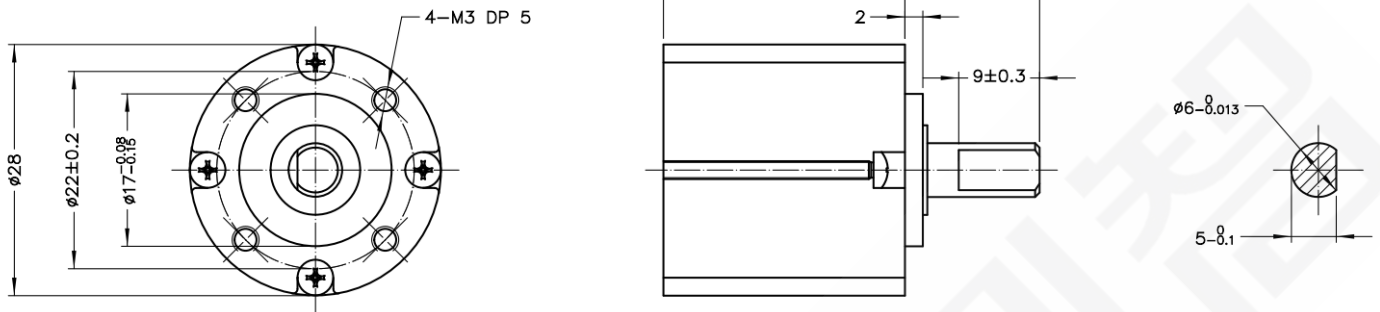

### Parameters

House material			Metal			
No load backlash			1°			
Bearing			Ball bearing			
Ratio	Rated torque (Kgf-cm)	Limit torque (Kgf-cm)	Stages	Efficiency (%)	Length (mm)	Mass (g)
3.3	5	15	1	90	21.2	87
4.6						
11.2	10	30	2	81	26.9	91
15.5						
21.5						
37.7	25	75	3	73	32.7	100
72						

## Accessories and Options

- 32 mm Frame Planetary Gearbox
- Dimensional Drawing

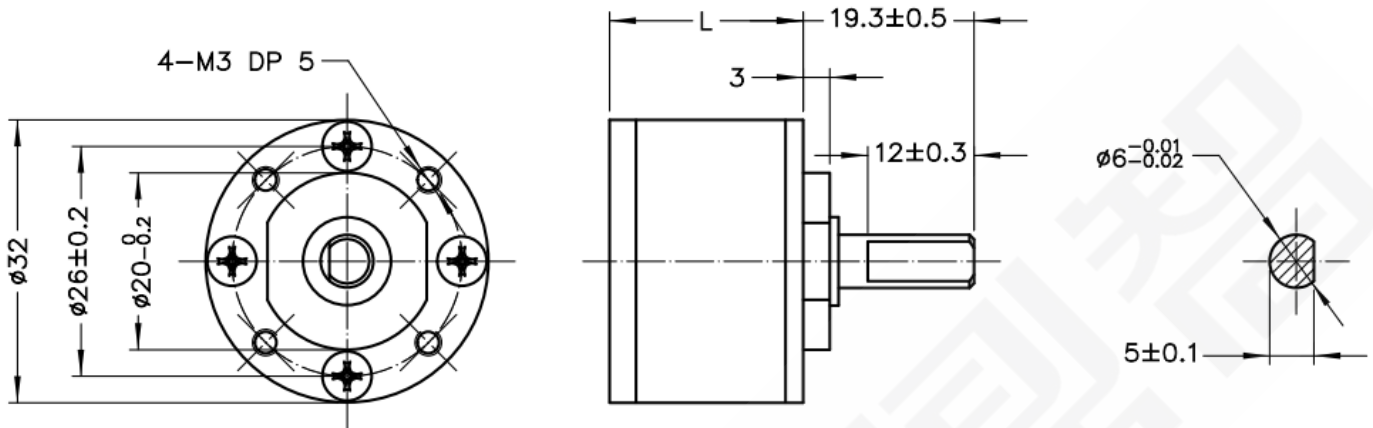

## Parameters

House material			Metal			
No load backlash			1°			
Bearing			Ball bearing			
Ratio	Rated torque (Kgf-cm)	Limit torque (Kgf-cm)	Stages	Efficiency (%)	Length (mm)	Mass (g)
3.3	5	15	1	90	16.2	90
4.6						
11.2	10	30	2	81	21.9	115
15.5						
21.5						
37.7	25	75	3	73	27.7	140
72						



- 42 mm Frame Planetary Gearbox
- Dimensional Drawing

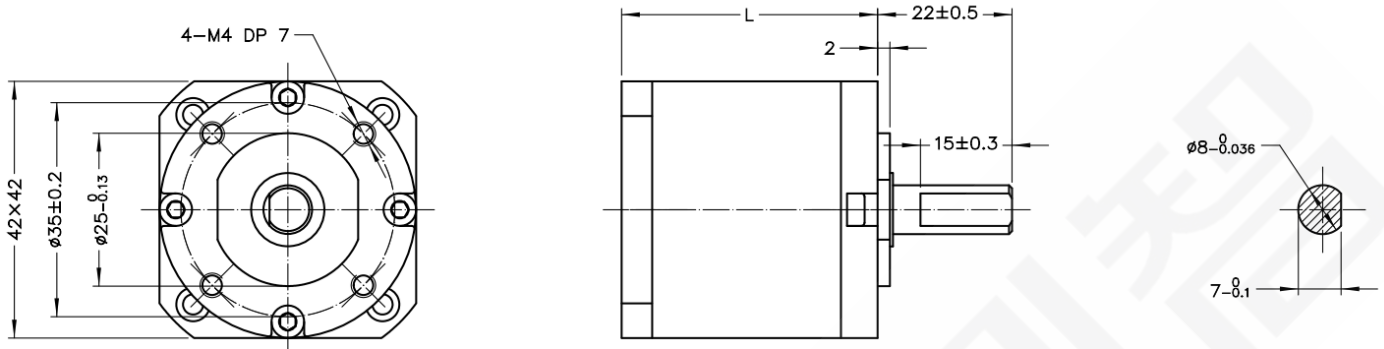

● **Parameters**

<b>House material</b>			Metal			
<b>No load backlash</b>			1.2°			
<b>Bearing</b>			Ball bearing			
Ratio	Rated torque (Kgf-cm)	Limit torque (Kgf-cm)	Stages	Efficiency (%)	Length (mm)	Mass (g)
3.7	10	30	1	90	30.6	260
5.2						
13.7	20	60	2	81	41.9	350
19.2						
26.9						
50.9	50	150	3	73	53.2	440
71.2						
99.5						

## Accessories and Options

- 57 mm Frame Planetary Gearbox
- Dimensional Drawing

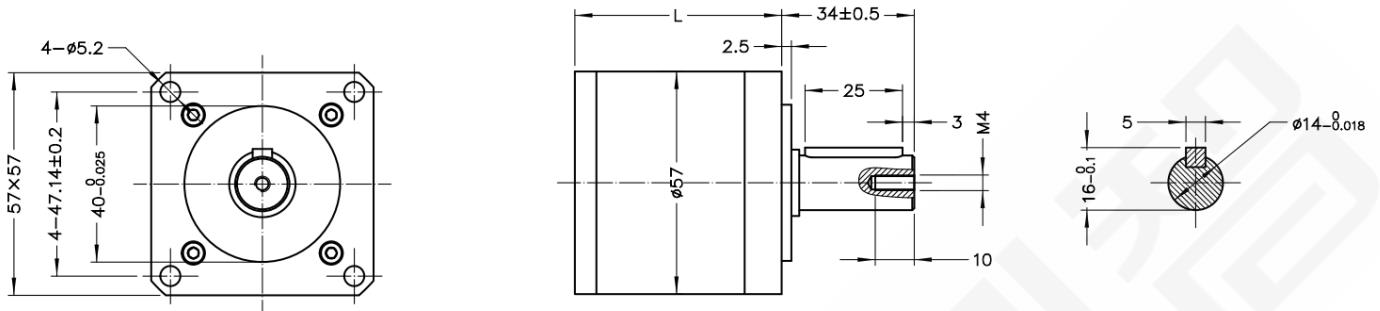

## Parameters

House material			Metal			
No load backlash			One stage 15 arcmin, two stages 25 arcmin			
Bearing			Ball bearing			
Ratio	Rated torque (Kgf-cm)	Limit torque (Kgf-cm)	Stages	Efficiency (%)	Length (mm)	Mass (g)
5	60	120	1	95	53	800
10						
15	250	400	2	90	70	1100
20						
25						

## Accessories and Options

- 60 mm Frame Planetary Gearbox
- Dimensional Drawing

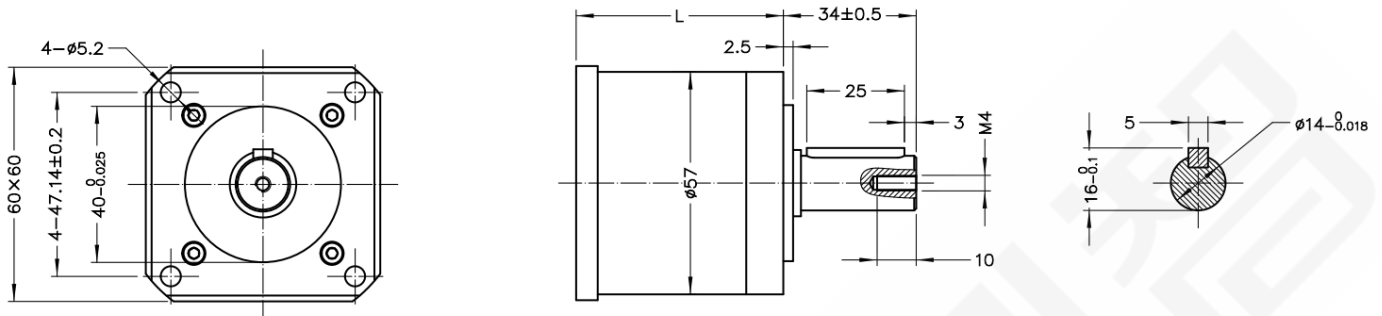

### Parameters

<b>House material</b>			Metal			
<b>No load backlash</b>			One stage 15 arcmin, two stages 25 arcmin			
<b>Bearing</b>			Ball bearing			
Ratio	Rated torque (Kgf-cm)	Limit torque (Kgf-cm)	Stages	Efficiency (%)	Length (mm)	Mass (g)
5	60	120	1	95	53	900
10						
15	250	400	2	90	70	1200
20						
25						

## Accessories and Options

### Optional Encoder

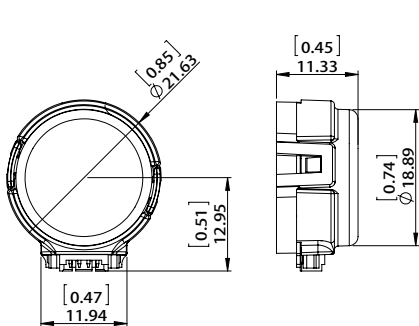

EK1 Encoder – single ended output

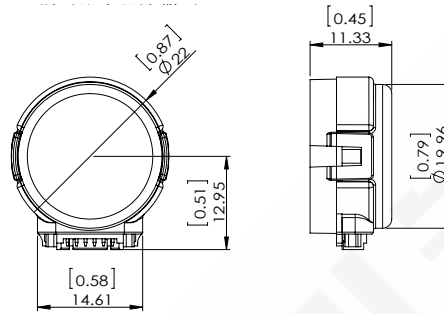

EK1 Encoder – differential output

#### ● EK1 Encoder (Used for Size 8, 11, 14, 17 Motor)

Resolution	100	108	120	125	128	200	250	256	300	360	400	500
Single ended output	0	1	2	3	4	5	6	7	8	9	10	11
Differential output	A	B	C	D	E	F	G	H	I	J	K	L

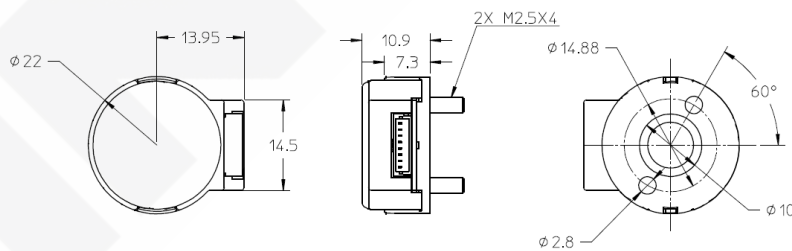

EK1 Encoder – differential output

#### ● EK5 Encoder (Used for Size 8, 11, 14, 17 Motor)\* With index

Resolution	360	500	512	1000	1024	2000	2048
Single ended output	0	1	2	3	4	5	6
Differential output	A	B	C	D	E	F	G

■ **Optional Encoder**

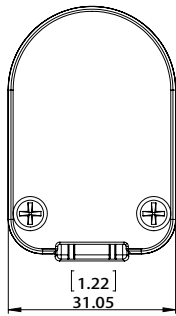

EK2 Encoder – single ended output

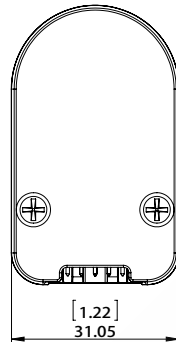
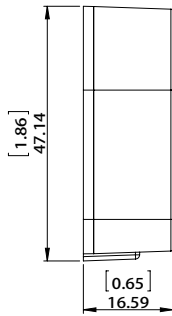

EK2 Encoder – differential output

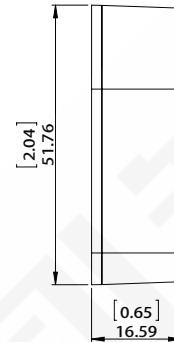

● **EK2 Encoder (Used for Size 14, 17, 23 Motor)**

Resolution	50	100	192	200	250	256	360	400	500	720	900	1000	1250	2000	2500	4000	5000
Single ended output	0	1	2	3	4	5	6	7	8	9	10	11	12				
Differential output	A	B	C	D	E	F	G	H	I	J	K	L	M	N	O	P	Q



## Accessories and Options

### Optional Encoder

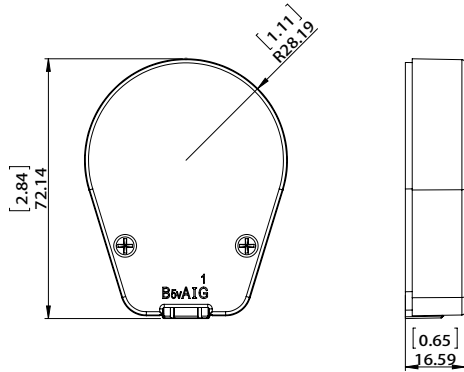

EK3 Encoder – single ended output

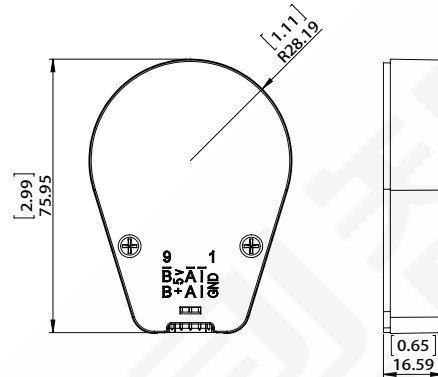

EK3 Encoder – differential output

#### EK3 Encoder (Used for Size 23, 34 Motor)

Resolution	64	100	200	500	1000	1800	2000	2500	3600	4000	5000	7200	8000	10000
Single ended output	0	1	2	3	4	5	6	7	8					
Differential output		A	B	C	D	E	F	G	H	I	J	K	L	M

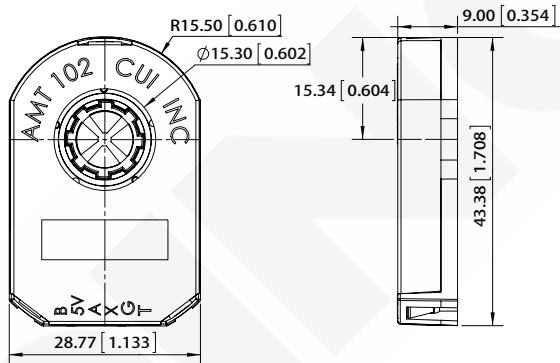

EK4 Encoder-single ended output (size14,17)

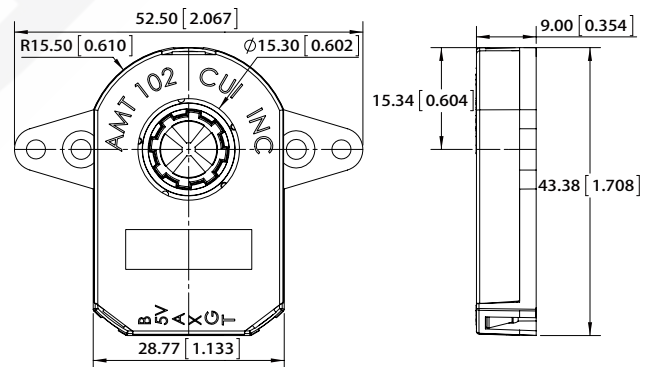

EK4 Encoder-single ended output (size23)

#### EK4 Encoder (Used for Size 14, 17, 23 Motor)

Resolution	48	96	100	125	192	200	250	256	384	400	500	512	800	1000	1024	2048
Single ended output	0	1	2	3	4	5	6	7	8	9	10	11	12	13	14	15
Differential output	-	-	-	-	-	-	-	-	-	-	-	-	-	-	-	-

# C Hollow shaft hybrid stepper

These Hollow shaft motor have 6 different sizes, from 20mm to 86mm. Each size has different stack lengths. Different sizes of inner holes, front and rear shafts can be provided. In addition, we can also customize the non-standard end machining of the shaft.

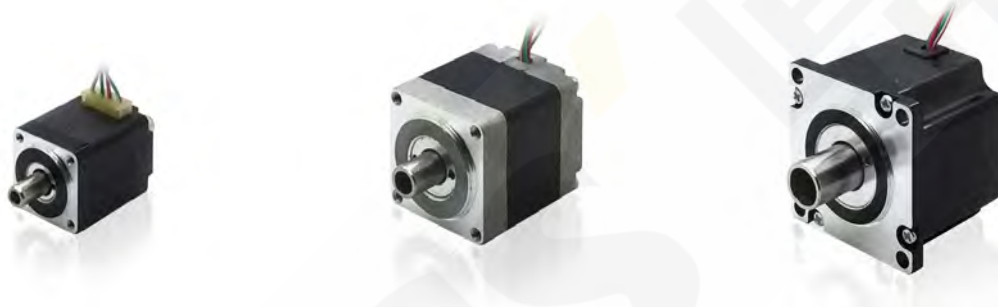

Part number construction	C-2
Product overview	C-3
Size 8 · 20 mm series	C-4
Size 11 · 28 mm series	C-6
Size 14 · 35 mm series	C-8
Size 17 · 42 mm series	C-10
Size 23 · 57 mm series	C-12
Size 34 · 86 mm series	C-14

## Part Number Construction

BACK TO

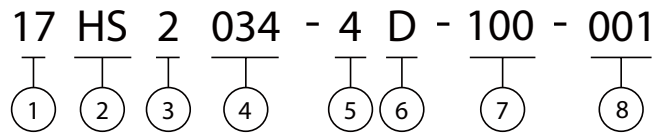

① NEMA Size (mm)

NEMA	08	11	14	17	23	24	34
MOTOR SIZE (mm)	20	28	35	42	57	60	86

② Motor Type

H = hollow shaft

③ Step Angle (°)

2 = 2 phase with 1.8°

4 = 2 phase with 0.9°

④ Motor Length/Stack

034 = motor length

⑤ Number Of Lead Wires

4 = qty 4 flying leads

6 = qty 6 flying leads

⑥ Shaft Configuration

D = double

S = single

⑦ Rated Current

100 = 1.0A

⑧ Customer Sequence Number

### Example

**Naming code**

17HS2034-4D-100-001

**Description**

Size 42 mm  
 Hollow shaft  
 Step angle 1.8°  
 Motor length 34 mm  
 4 wiring leads  
 Dual shaft  
 Customization sequence 01

Size (mm)	Motor length (mm)	Holding torque (N.m)	Inner holes (mm)	(W)
8 (20*20)	27.2	0.014	3	2.4
	38.1	0.02	3	4
11 (28*28)	33.35	0.053	5	4.2
	45	0.117	5	7.5
14 (35*35)	33.6	0.19	8	5.7
	45.6	0.36	8	9.1
17 (42*42)	34.1	0.31	8	7
	48.1	0.56	8	13
23 (57*57)	45	1.2	13	13
	65	2.1	13	25
34 (86*86)	76	4.5	16	31

## Size 8 (20 mm) Series

BACK TO



### Motor Characteristics

Model No.	Rated Voltage (V)	Current (A)	Resistance (Ω)	Inductance (mH)	Holding Torque (N.m)	Detent Torque (N.m)	Motor length "L"(mm)
8HS2028	2.55	0.5	5.1	1.5	0.014	0.002	27.2
8HS2038	4.4	0.5	8.8	2.7	0.020	0.002	38.1

### Dimensional Drawings

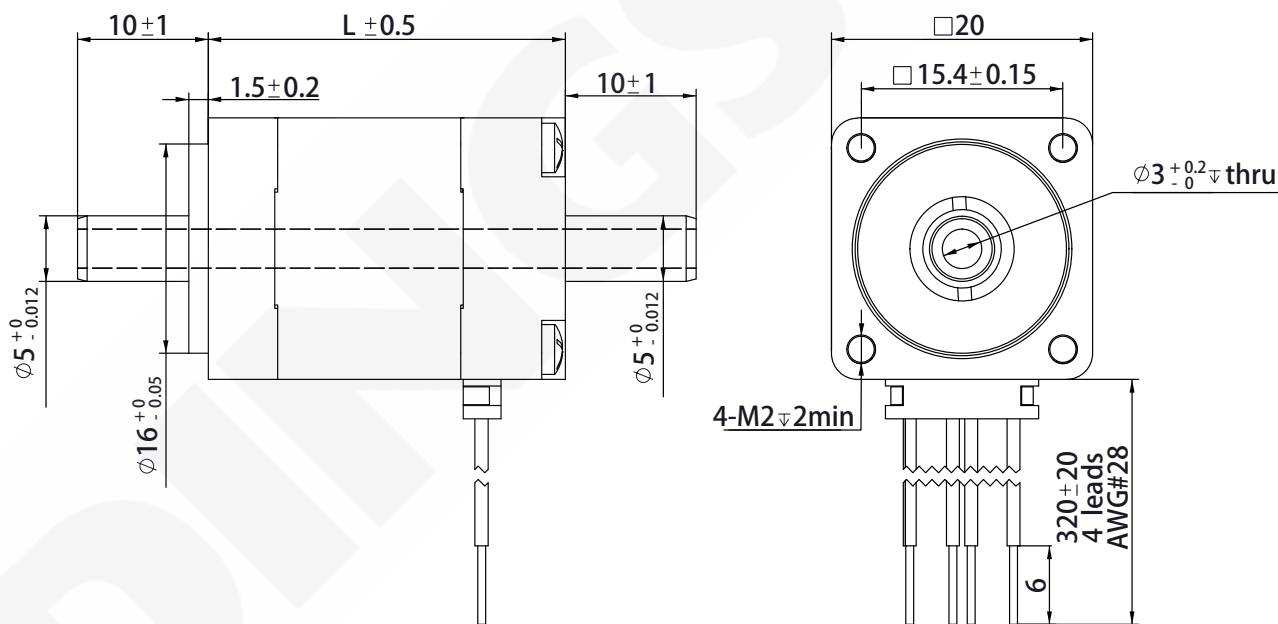



**Torque Performance Curves**

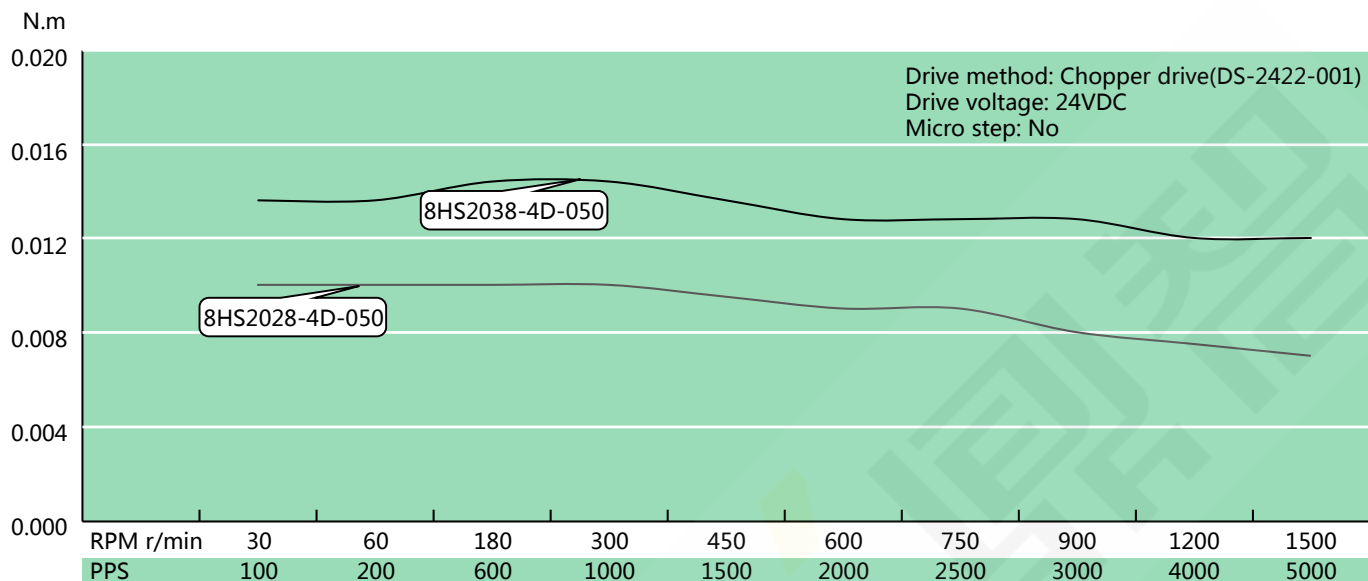

## Size 11 (28 mm) Series

BACK TO



### Motor Characteristics

Model No.	Rated Voltage (V)	Current (A)	Resistance ( $\Omega$ )	Inductance (mH)	Holding Torque (N.m)	Detent Torque (N.m)	Motor length "L"(mm)
11HS2033	2.1	1.0	2.1	1.5	0.053	0.004	33.5
11HS2045	4.1	1.0	4.1	4.0	0.117	0.004	45

### Dimensional Drawings

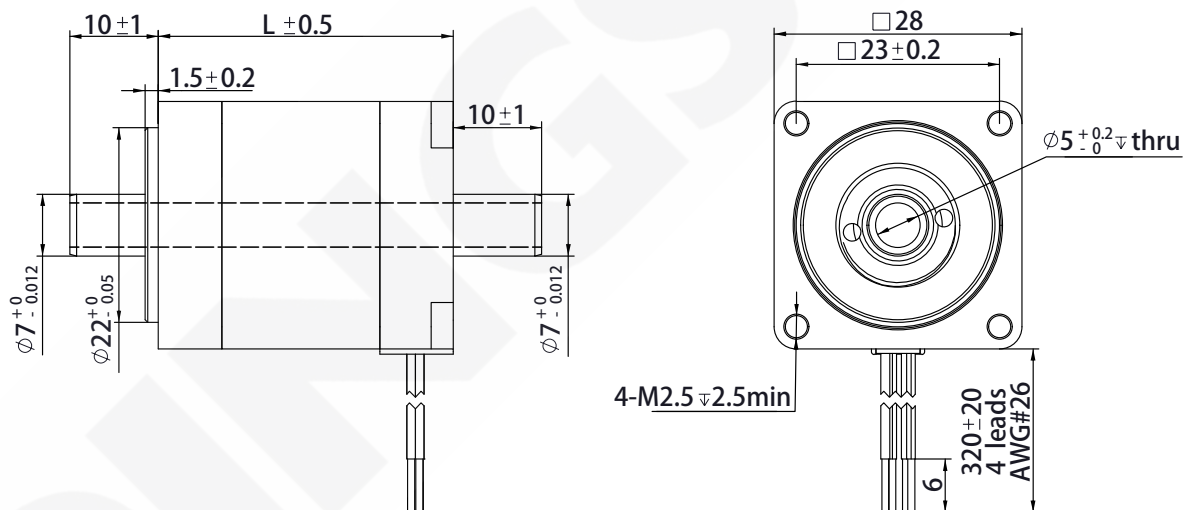

### Torque Performance Curves

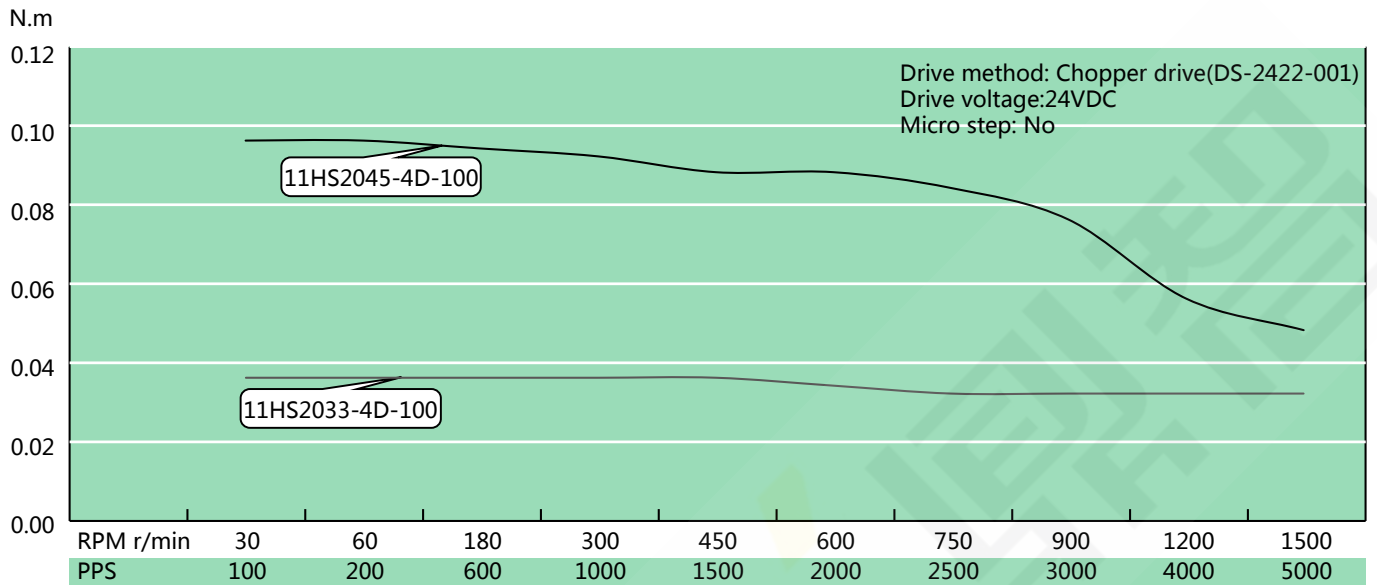

## Size 14 (35 mm) Series

BACK TO



### Motor Characteristics

Model No.	Rated Voltage (V)	Current (A)	Resistance (Ω)	Inductance (mH)	Holding Torque (N.m)	Detent Torque (N.m)	Motor length "L"(mm)
14HS2033	3.5	1.0	3.5	3.6	0.19	0.008	33.6
14HS2045	6	1.0	6	7.2	0.36	0.013	45.6

### Dimensional Drawings

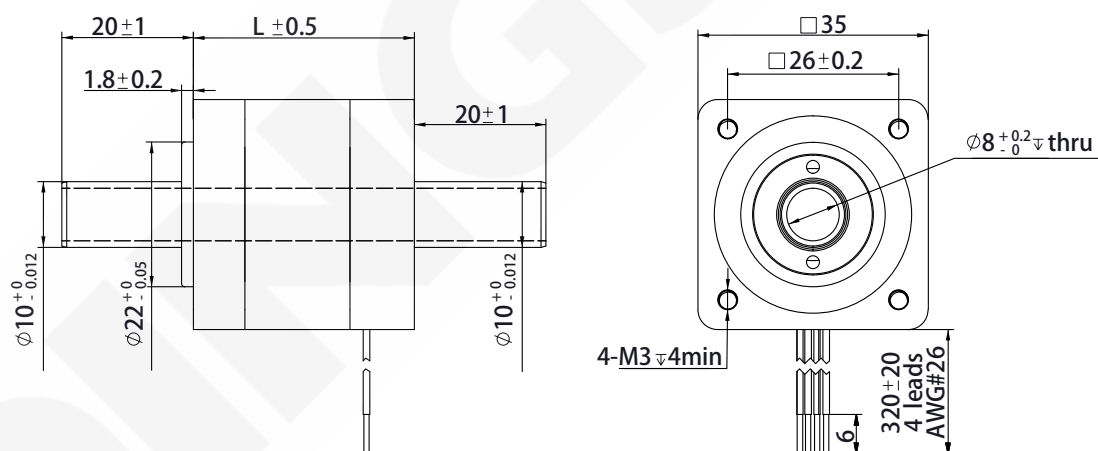

### Torque Performance Curves

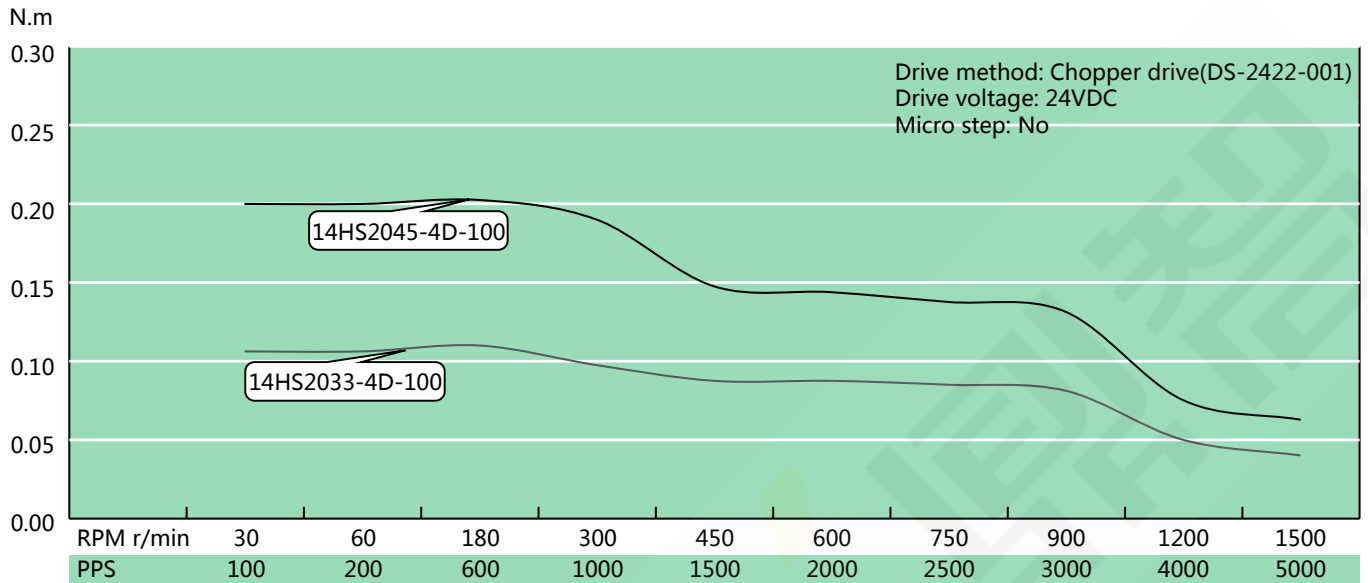



## Size 17 (42 mm) Series

BACK TO



### Motor Characteristics

Model No.	Rated Voltage (V)	Current (A)	Resistance ( $\Omega$ )	Inductance (mH)	Holding Torque (N.m)	Detent Torque (N.m)	Motor length "L"(mm)
17HS2034	3.8	1.0	3.8	5.0	0.31	0.014	34.1
17HS2048	2.5	2.5	1.0	1.8	0.56	0.018	48.1

### Dimensional Drawings

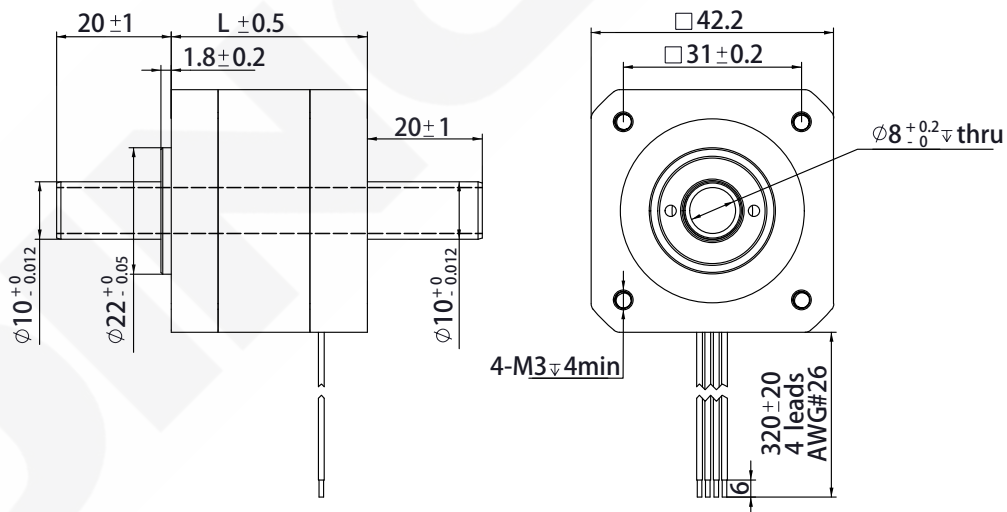

### Torque Performance Curves

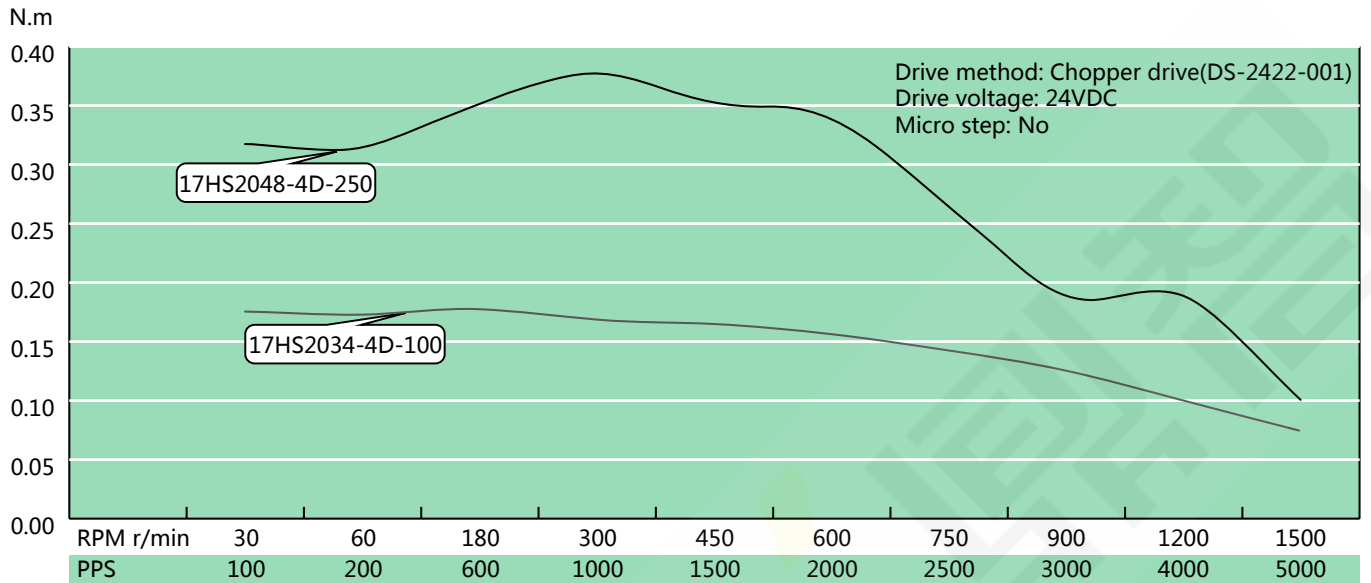

## Size 23 (57 mm) Series

RACK TO



### Motor Characteristics

Model No.	Rated Voltage (V)	Current (A)	Resistance ( $\Omega$ )	Inductance (mH)	Holding Torque (N.m)	Detent Torque (N.m)	Motor length "L"(mm)
23HS2045	3.5	2.0	1.75	4.1	1.2	0.020	45
23HS2065	5.0	2.5	2.0	5.2	2.1	0.040	65

### Dimensional Drawings

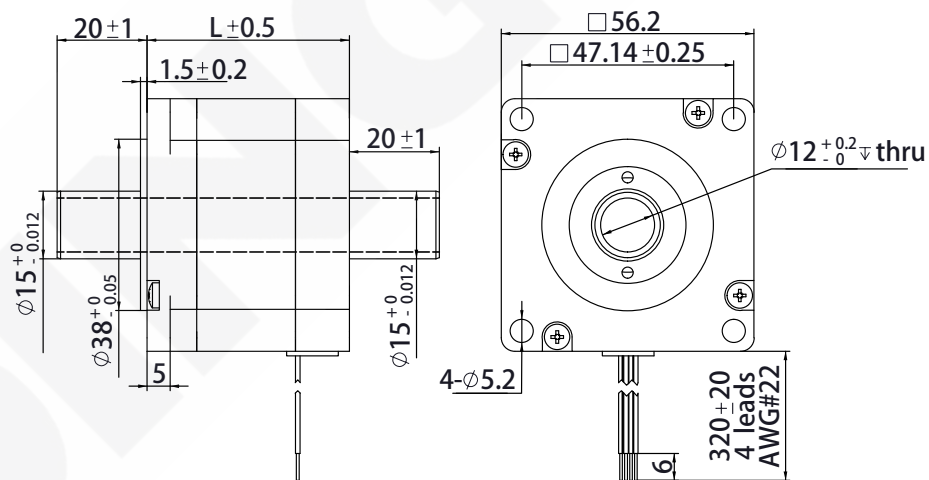

**Torque Performance Curves**

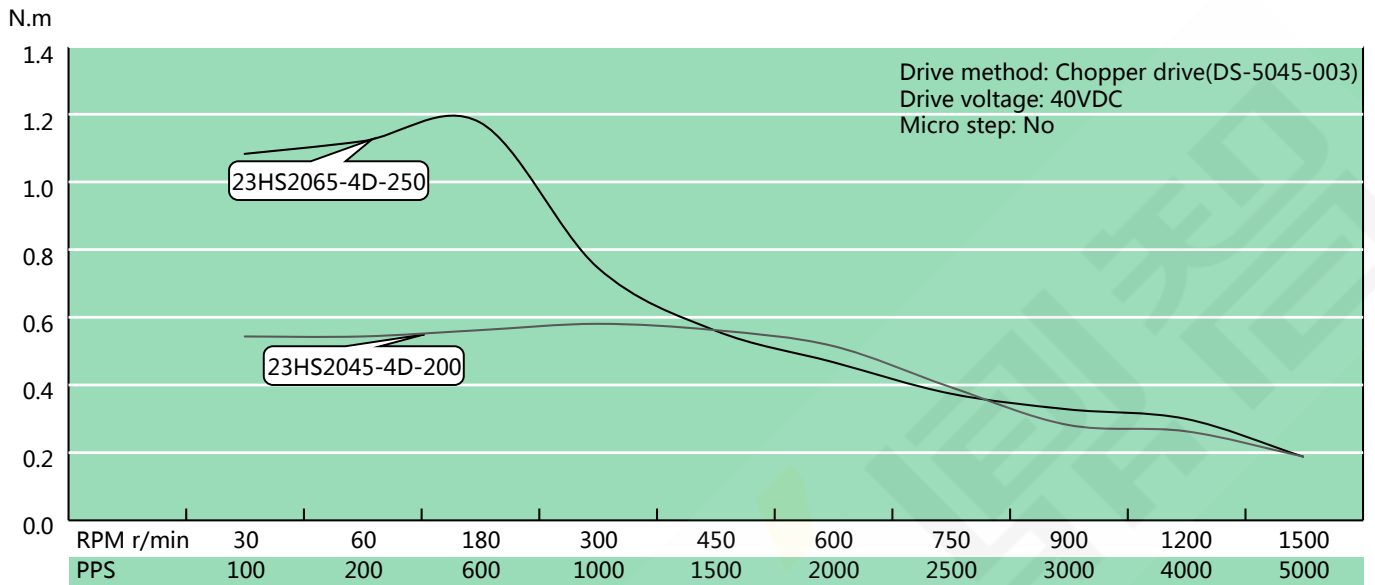

## Size 34 (86 mm) Series

BACK TO

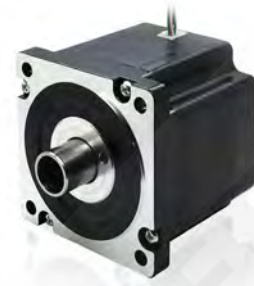

### Motor Characteristics

Model No.	Rated Voltage (V)	Current (A)	Resistance ( $\Omega$ )	Inductance (mH)	Holding Torque (N.m)	Detent Torque (N.m)	Motor length "L"(mm)
34HS2076	5.7	3.0	1.9	19	4.5	0.095	76

### Dimensional Drawings

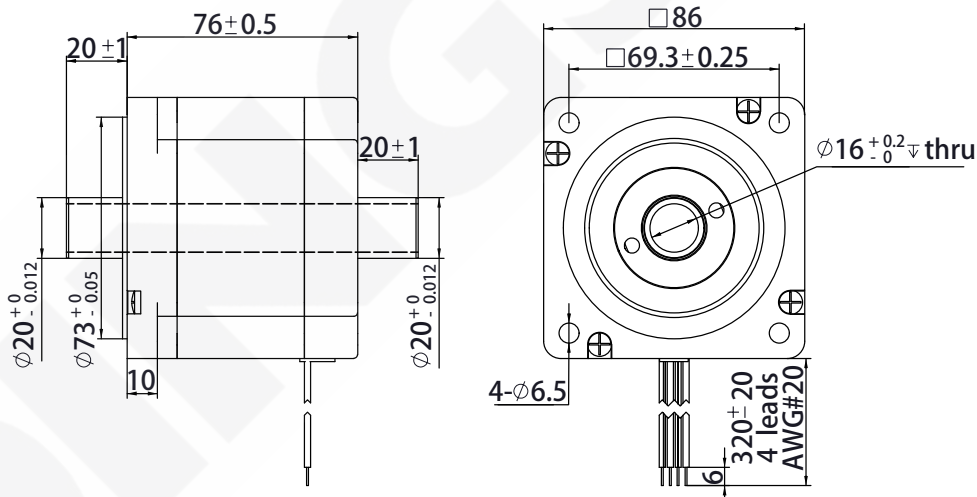



**Torque Performance Curves**

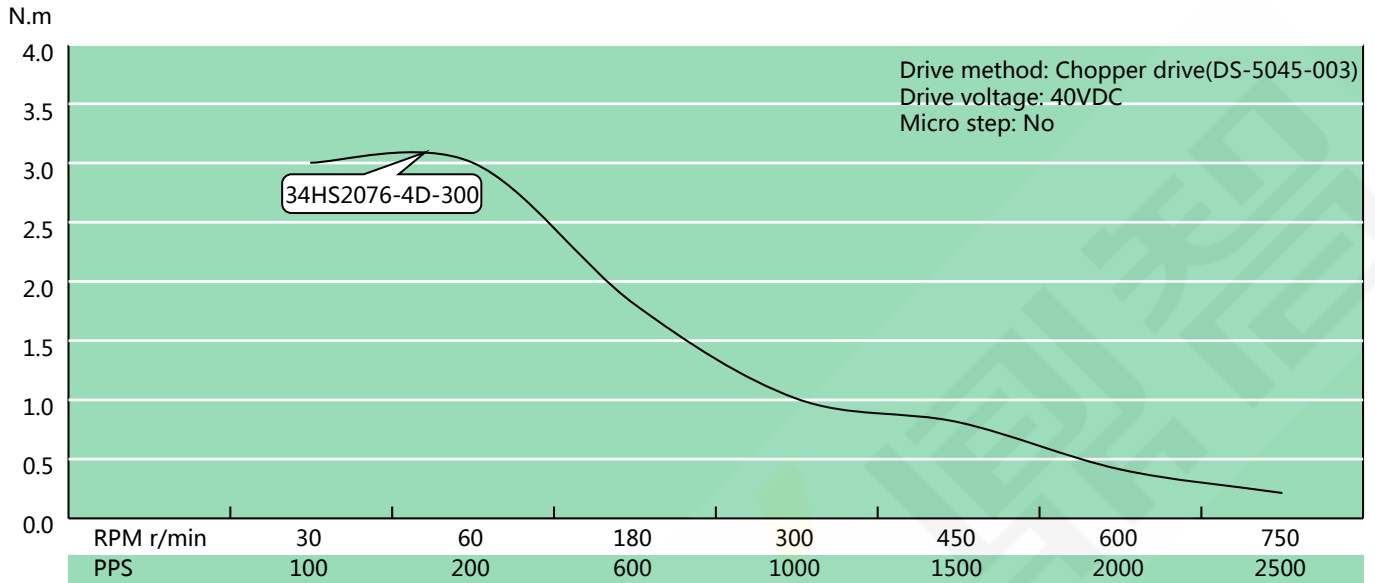

# D Brushless DC motor

The outstanding advantages of BLDC motor is the convenience of speed regulation, higher power density and over load capacity. We supply eight sizes from 17 to 43 and three lengths per size.



Part number construction

D-2

Size 17 · 42 mm series

D-3

Size 23 · 57 mm series

D-4

Size 24 · 60 mm series

D-5

Size 28 · 70 mm series

D-6

Size 32 · 80 mm series

D-7

Size 34 · 86 mm series

D-8

Size 40 · 100 mm series

D-9

Size 43 · 110 mm series

D-10

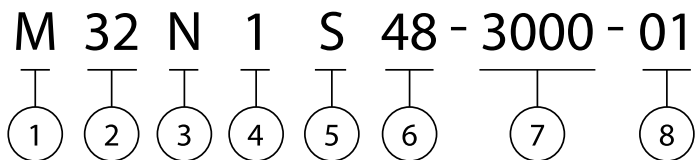

- ① **Motor**  
 M = motor  
 D = drive  
 E = motor with integrated drive

- ② **Motor Size**

CODE	17	23	24	28	32	34	40	43
MOTOR SIZE (mm)	42	57	60	70	80	86	100	110

- ③ **Derivations From Different Magnetic, insulation or other customization E.G.**  
 N = ordinary type,  
 F = F class insulation,  
 P = IP65
- ④ **Length Code**
- ⑤ **Commutation**  
 S = Brushless  
 Z = Brushed
- ⑥ **Norminal Voltage**
- ⑦ **Rated Speed**
- ⑧ **Customer Sequence Number**

**Example**

**Naming code** M32N1S48-3000-01

**Description** 80 mm frame size  
 94 mm length  
 Rated as 48 V and 3000 RPM  
 Customization sequence code 01

## Size 17 · 42 mm Series

BACK TO



M17 Frame		M17N1	M17N2	M17N3	
<b>General</b>					
Insulation Class		B			
Duty Type		S1			
Feed Back Method		Hall Sensors			
Commutation Angle		120°			
Winding Connection		Star			
Dielectrical Strength		500 VAC / 1 KHz / 1 mA / 1 s			
Insulation Resistance		100 MΩ / 500 VDC			
<b>Performance</b>					
Nominal Voltage	$U_N$	V	24		
Rated Power	$P_N$	W	31	62	94
Rated Torque	$T_N$	N · m	0.1	0.2	0.3
Rated Speed	$n_N$	RPM	3000		
Rated Current	$I_N$	A	1.8	3.4	5.2
Back EMF Constant	$K_E$	V / KRPM	5.86		
Torque Constant	$K_T$	N · m / A	0.056		
Poles	-	-	8		
Length	L	mm	52	70	90
Mass	-	Kg	0.35	0.55	0.65
<b>Material</b>					
End Cap		Aluminium Alloy			
Bearing		Deep Groove Ball Bearings			
Magnetic		Sintered NdFeB			
Shaft		Stainless Steel			

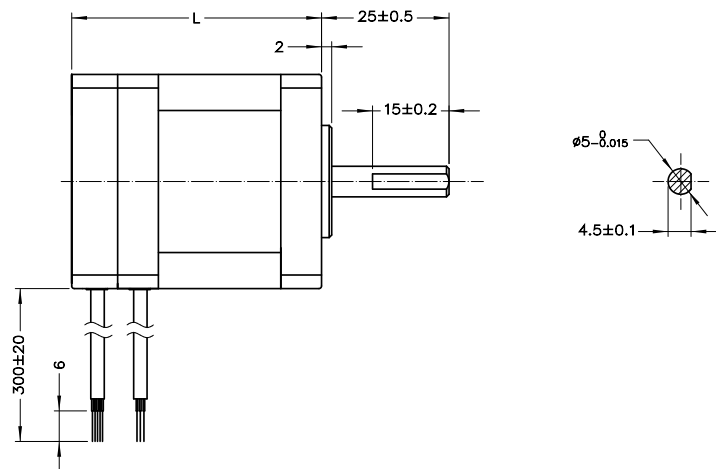
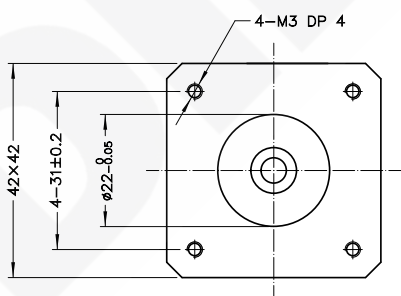

## Size 23 - 57 mm Series

BACK TO

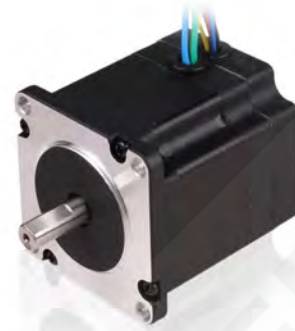

M23 Frame		M23N1	M23N2	M23N3	
<b>General</b>					
Insulation Class		B			
Duty Type		S1			
Feed Back Method		Hall Sensors			
Commutation Angle		120°			
Winding Connection		Star			
Dielectrical Strength		500 VAC / 1 KHz / 1 mA / 1 s			
Insulation Resistance		100 MΩ / 500 VDC			
<b>Performance</b>					
Nominal Voltage	$U_N$	V	24		
Rated Power	$P_N$	W	63	126	188
Rated Torque	$T_N$	N · m	0.2	0.4	0.6
Rated Speed	$n_N$	RPM	3000		
Rated Current	$I_N$	A	3.4	6.9	10.5
Back EMF Constant	$K_E$	V / KRPM	5.86		
Torque Constant	$K_T$	N · m / A	0.056		
Poles	-	-	8		
Length	L	mm	60	80	100
Mass	-	Kg	0.55	0.9	1.25
<b>Material</b>					
End Cap		Aluminium Alloy			
Bearing		Deep Groove Ball Bearings			
Magnetic		Sintered NdFeB			
Shaft		40Cr			

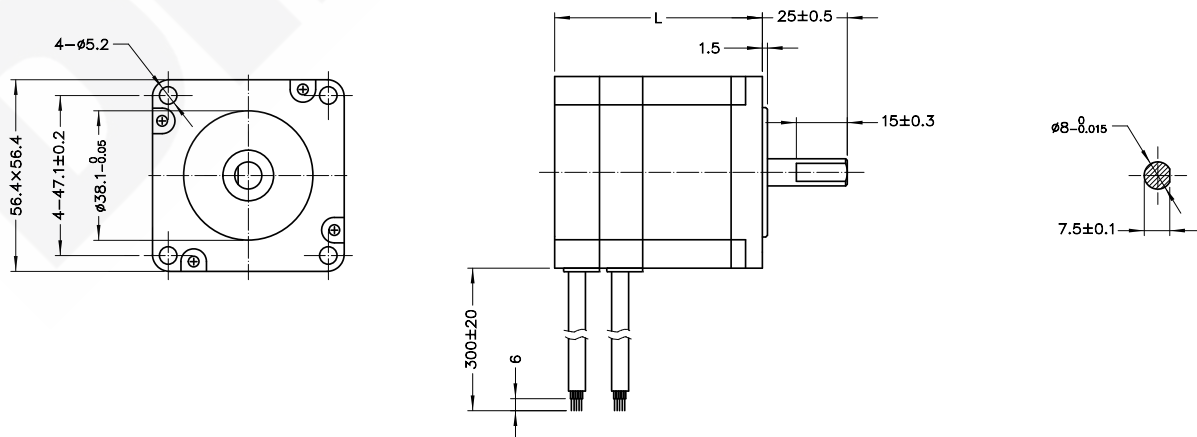



## Size 24 · 60 mm Series



BACK TO

M24 Frame		M24N1	M24N2	M24N3	
<b>General</b>					
Insulation Class		B			
Duty Type		S1			
Feed Back Method		Hall Sensors			
Commutation Angle		120°			
Winding Connection		Star			
Dielectrical Strength		500 VAC / 1 KHz / 1 mA / 1 s			
Insulation Resistance		100 MΩ / 500 VDC			
<b>Performance</b>					
Nominal Voltage	$U_N$	V	24		
Rated Power	$P_N$	W	78	157	235
Rated Torque	$T_N$	N · m	0.25	0.5	0.75
Rated Speed	$n_N$	RPM	3000		
Rated Current	$I_N$	A	4.4	8.7	13.1
Back EMF Constant	$K_E$	V / KRPM	5.86		
Torque Constant	$K_T$	N · m / A	0.056		
Poles	-	-	8		
Length	L	mm	78	99	120
Mass	-	Kg	0.85	1.25	1.7
<b>Material</b>					
End Cap		Aluminium Alloy			
Bearing		Deep Groove Ball Bearings			
Magnetic		Sintered NdFeB			
Shaft		40Cr			

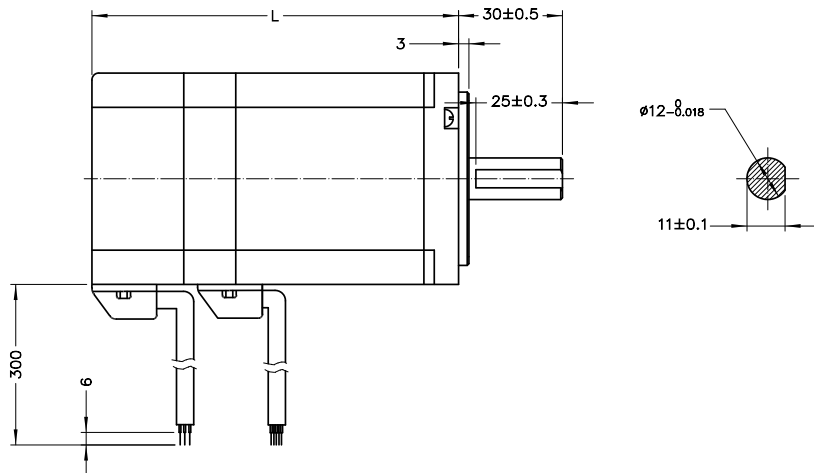
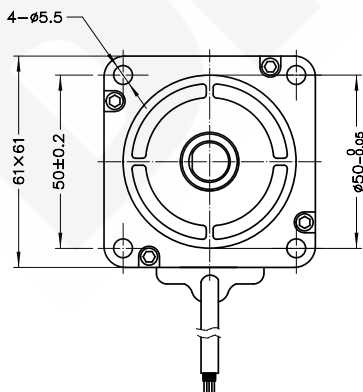

**Size 28 - 70 mm Series**

**BACK TO**

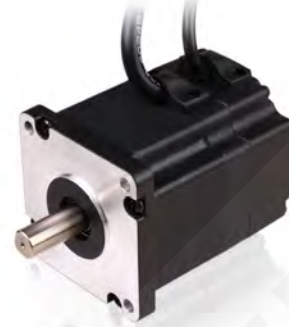

M28 Frame		M28N1	M28N2	M28N3	
<b>General</b>					
Insulation Class		B			
Duty Type		S1			
Feed Back Method		Hall Sensors			
Commutation Angle		120°			
Winding Connection		Star			
Dielectrical Strength		500 VAC / 1 KHz / 1 mA / 1 s			
Insulation Resistance		100 MΩ / 500 VDC			
<b>Performance</b>					
Nominal Voltage	$U_N$	V	48		
Rated Power	$P_N$	W	157	315	470
Rated Torque	$T_N$	N · m	0.5	1	1.5
Rated Speed	$n_N$	RPM	3000		
Rated Current	$I_N$	A	4.4	8.7	13.1
Back EMF Constant	$K_E$	V / KRPM	12		
Torque Constant	$K_T$	N · m / A	0.115		
Poles	-	-	8		
Length	L	mm	87	120	150
Mass	-	Kg	1.3	2.1	2.8
<b>Material</b>					
End Cap		Aluminium Alloy			
Bearing		Deep Groove Ball Bearings			
Magnetic		Sintered NdFeB			
Shaft		40Cr			

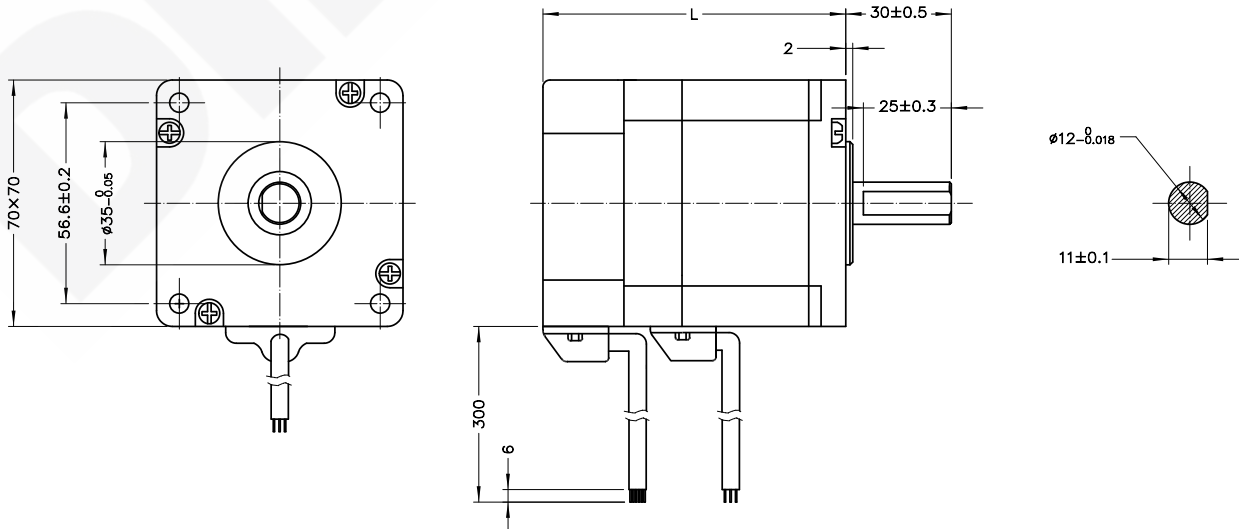

**Size 32 - 80 mm Series**

BACK TO



M32 Frame		M32N1	M32N2	M32N3	
<b>General</b>					
Insulation Class		B			
Duty Type		S1			
Feed Back Method		Hall Sensors			
Commutation Angle		120°			
Winding Connection		Star			
Dielectrical Strength		500 VAC / 1 KHz / 1 mA / 1 s			
Insulation Resistance		100 MΩ / 500 VDC			
<b>Performance</b>					
Nominal Voltage	$U_N$	V	48	310	
Rated Power	$P_N$	W	314	471	628
Rated Torque	$T_N$	N · m	1	1.5	2
Rated Speed	$n_N$	RPM	3000		
Rated Current	$I_N$	A	8.7	13	2.7
Back EMF Constant	$K_E$	V / KRPM	12		
Torque Constant	$K_T$	N · m / A	0.115		
Poles	-	-	4		
Length	L	mm	95	125	145
Mass	-	Kg	1.8	2.8	3.6
<b>Material</b>					
End Cap		Aluminium Alloy			
Bearing		Deep Groove Ball Bearings			
Magnetic		Sintered NdFeB			
Shaft		40Cr			

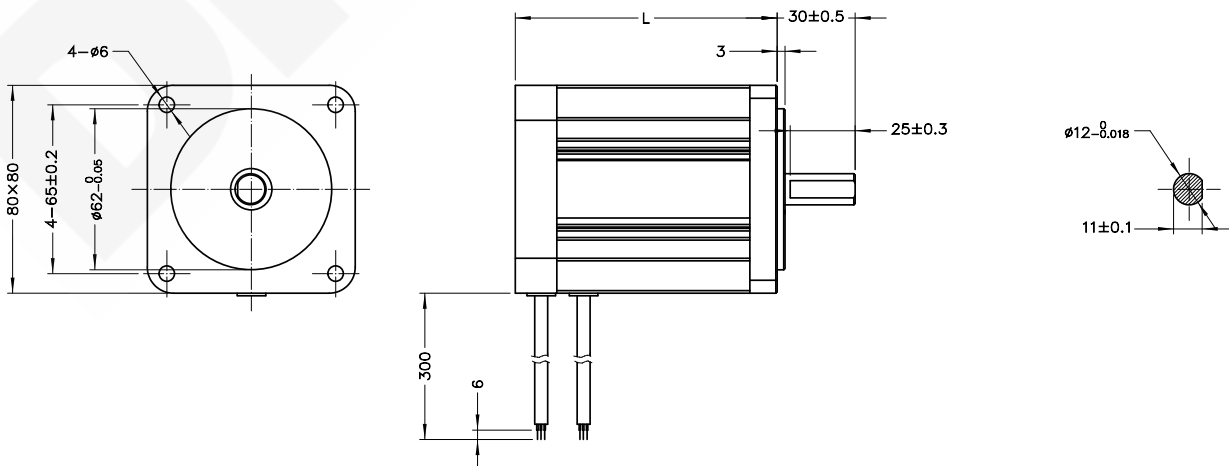

**Size 34 - 86 mm Series**

**BACK TO**



M34 Frame		M34N1	M34N2	M34N3	
<b>General</b>					
Insulation Class		B			
Duty Type		S1			
Feed Back Method		Hall Sensors			
Commutation Angle		120°			
Winding Connection		Star			
Dielectrical Strength		500 VAC / 1 KHz / 1 mA / 1 s			
Insulation Resistance		100 MΩ / 500 VDC			
<b>Performance</b>					
Nominal Voltage	$U_N$	V	48	310	
Rated Power	$P_N$	W	220	440	660
Rated Torque	$T_N$	N · m	0.7	1.4	2.1
Rated Speed	$n_N$	RPM	3000		
Rated Current	$I_N$	A	6.1	12.2	2.8
Back EMF Constant	$K_E$	V / KRPM	12	78.5	
Torque Constant	$K_T$	N · m / A	0.115	0.75	
Poles	-	-	8		
Length	L	mm	97	124	151
Mass	-	Kg	1.85	2.6	4
<b>Material</b>					
End Cap		Aluminium Alloy			
Bearing		Deep Groove Ball Bearings			
Magnetic		Sintered NdFeB			
Shaft		40Cr			

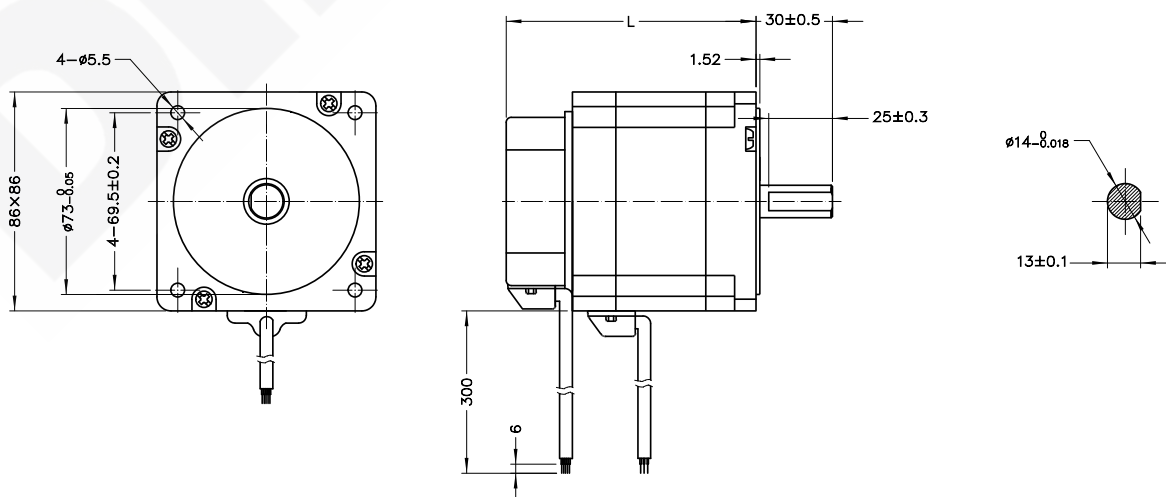

## Size 40 - 100 mm Series

BACK TO



M40 Frame		M40N1	M40N2
<b>General</b>			
Insulation Class		B	
Duty Type		S1	
Feed Back Method		Hall Sensors	
Commutation Angle		120°	
Winding Connection		Star	
Dielectrical Strength		500 VAC / 1 KHz / 1 mA / 1 s	
Insulation Resistance		100 MΩ / 500 VDC	
<b>Performance</b>			
Nominal Voltage	$U_N$	V	310
Rated Power	$P_N$	W	847
Rated Torque	$T_N$	N · m	2.7
Rated Speed	$n_N$	RPM	3000
Rated Current	$I_N$	A	3.6
Back EMF Constant	$K_E$	V / KRPM	78.5
Torque Constant	$K_T$	N · m / A	0.75
Poles	-	-	8
Length	L	mm	128
Mass	-	Kg	3
<b>Material</b>			
End Cap		Aluminium Alloy	
Bearing		Deep Groove Ball Bearings	
Magnetic		Sintered NdFeB	
Shaft		40Cr	

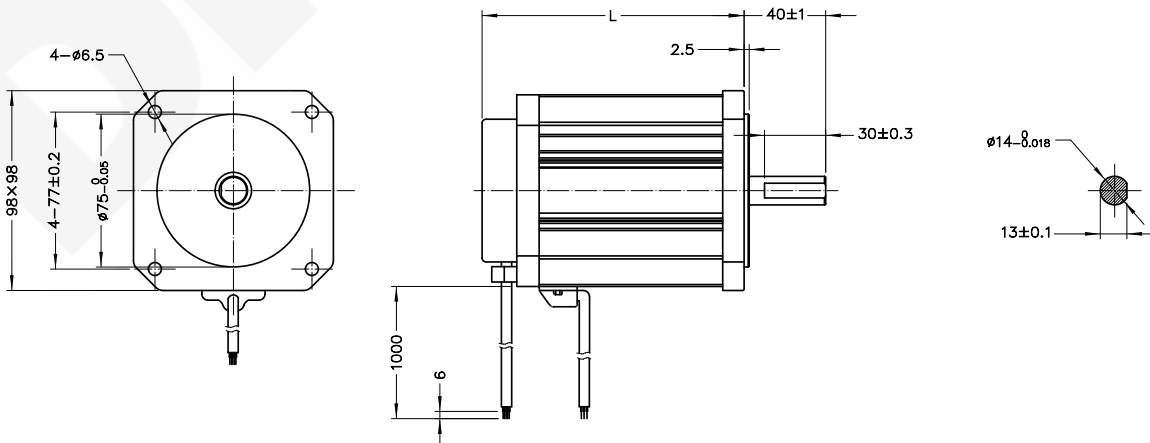



## Size 43 · 110 mm Series

BACK TO



M43 Frame		M43N1	M43N2	M43N3	
<b>General</b>					
Insulation Class		B			
Duty Type		S1			
Feed Back Method		Hall Sensors			
Commutation Angle		120°			
Winding Connection		Star			
Dielectrical Strength		500 VAC / 1 KHz / 1 mA / 1 s			
Insulation Resistance		100 MΩ / 500 VDC			
<b>Performance</b>					
Nominal Voltage	$U_N$	V	310		
Rated Power	$P_N$	W	1256	1885	2513
Rated Torque	$T_N$	N · m	4	6	8
Rated Speed	$n_N$	RPM	3000		
Rated Current	$I_N$	A	5.1	7.7	10.2
Back EMF Constant	$K_E$	V / KRPM	82.1		
Torque Constant	$K_T$	N · m / A	0.78		
Poles	-	-	8		
Length	L	mm	155	180	210
Mass	-	Kg	4.5	7	9.5
<b>Material</b>					
End Cap		Aluminium Alloy			
Bearing		Deep Groove Ball Bearings			
Magnetic		Sintered NdFeB			
Shaft		40Cr			

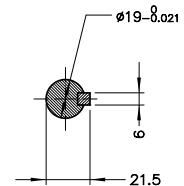
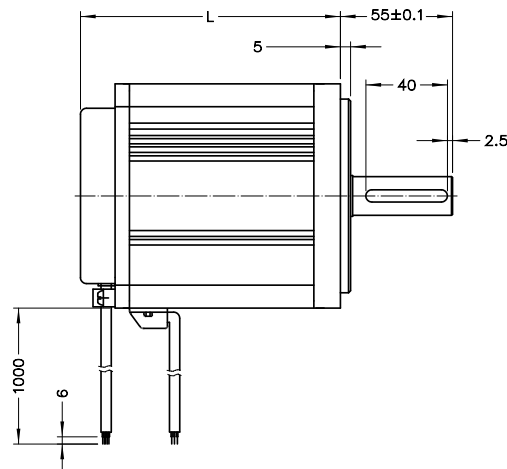
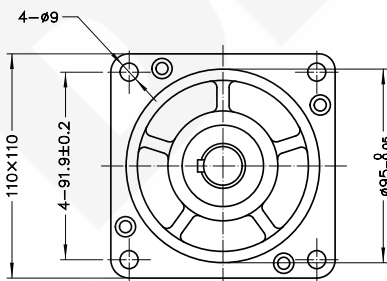

# E Stepper motor driver

DINGS supplies drivers based on the latest 32 bit DSP and digital microstep technology. It enables to create smooth commutation of advanced performances, accurate positioning, less noise and lower temperature. In addition, closed loop and integrated drive options are available.



DS-2422-001

E-2

DS-5045-003

E-3

DS-2MSD8078-2

E-4

DS-OL17/23-I series

E-5

ST-484 close loop driver

E-11

Vector series integrated systems

E-13

DS-CL28-SA Integrated closed-loop drive

E-18

## DS-2422-001

### Preparations To Operate

1. Recommend to use appropriate power supply [8~36VDC]
2. Controller, PLC or controller block [High speed pulse]
3. Recommend to use 2 phase, 4 lead wire of Step motors.

### Power Supply Connection

1. Power supply range is 8~36VDC but recommend to select 24V available under Size 8, 11, 14, 17 of Step motors.
2. Please connect "+" to the "VDC" and "-" to the GND.

Description	Min	Rating	Max
Current RMS(A)	0.2	-	2.2
Power Voltage (VDC)	8	24	36
Signal current (mA)	6	10	16
Pulse frequency (KHz)	0	-	300
Pulse width(us)	2	-	-
Direction signal width(us)	100	-	-
Undervoltage protection(VDC)	-	7.5	-
Oversvoltage protection (VDC)	-	42	-
Cooling mode	Natural cooling		
Ambient temperature(°C)	0~50		
Ambient humidity (%RH)	40~90%		
Vibration	10~55HZ/0.15mm		
Storage temperature (°C)	-20~65		
Weight(g)	180		

### Installation Instructions

1. Reliable operation temperature for Driver should be less than 60°C [135°F] and motor should be less than 85°C [176°F]
2. Recommend to use Automatic Idle-Current mode. It enables to reduce current as 60% when motor stops then help to minimize heating of motor and driver.
3. Recommend to mount driver vertically to maximize heat sink area. If necessary, please apply additional cooling method to cool-down the system.



DS-2422-001  
Fit 20 28 35 42 Motor

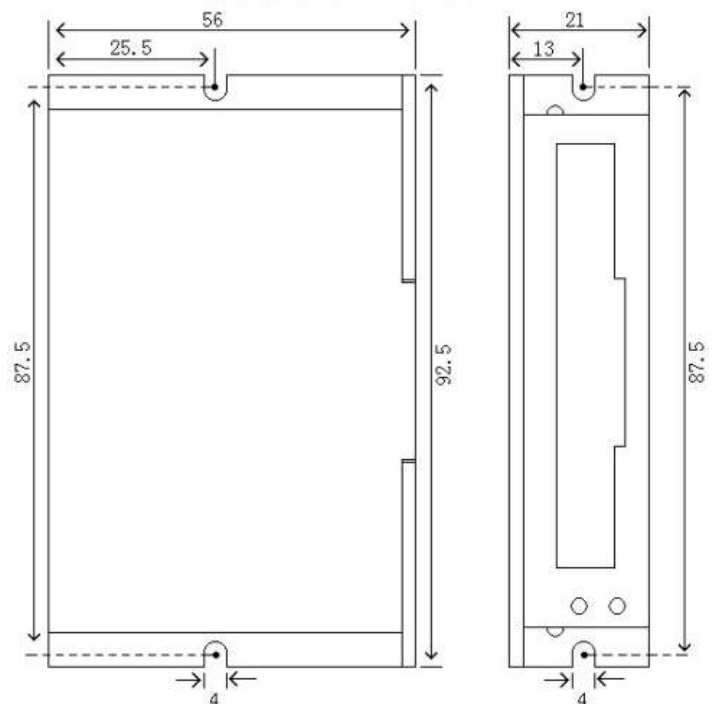

(Side mounting, Good heat dissipation)

BACK TO

**DS-5045-003**

**Preparations To Operate**

1. Recommend to use appropriate power supply [18~90VDC]
2. Controller, PLC or controller block [High speed pulse]
3. Recommend to use 2 phase, 4 lead wire of Step motors.

**Power Supply Connection**

1. Power supply range is 18~90VDC but recommend to select 24V available under Size 14,17, 23,34 of Step motors.
2. Please connect "+" to the "VDC" and "-" to the GND.

Description	Min	Rating	Max
Current RMS(A)	1.0	-	4.5
Power Voltage (VDC)	18	50	90
Signal current (mA)	5	10	20
Pulse frequency (KHz)	0	-	300
Pulse width(us)	2	-	-
Direction signal width(us)	100	-	-
Undervoltage protection(VDC)	-	7.5	-
Overvoltage protection (VDC)	-	95	-
Cooling mode	Natural cooling		
Ambient temperature(°C)	0~50		
Ambient humidity (%RH)	40~90%		
Vibration	10~55HZ/0.15mm		
Storage temperature (°C)	-20~65		
Weight(g)	250		

**Installation Instructions**

1. Reliable operation temperature for Driver should be less than 60°C [135°F] and motor should be less than 85°C [176°F]
2. Recommend to use Automatic Idle-Current mode. It enables to reduce current as 60% when motor stops then help to minimize heating of motor and driver.
3. Recommend to mount driver vertically to maximize heat sink area. If necessary, please apply additional cooling method to cool-down the system.



DS-5045-003 Driver  
Fit 35 42 57 86 Motor

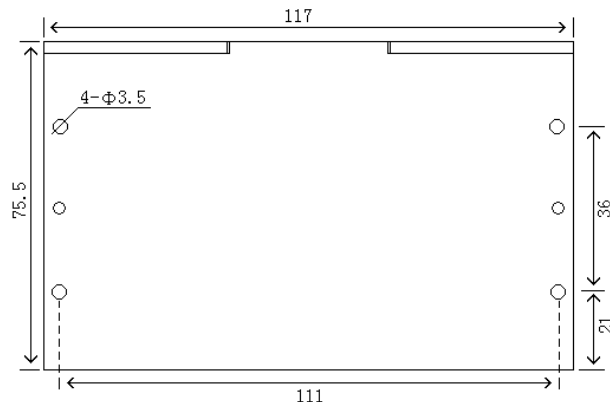
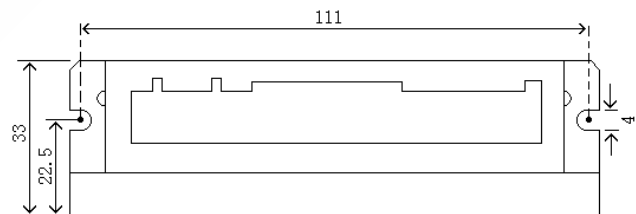

(Side mounting, Good heat dissipation)



## DS-2MSD8078-2

### Preparations To Operate

1. Recommend to use appropriate power supply [36~80VDC]
2. Controller, PLC or controller block [High speed pulse]
3. Recommend to use 2 phase, 4 lead wire of Step motors.

### Power Supply Connection

1. Power supply range is 18~90VDC but recommend to select 24V available under Size 23,34 of Step motors.
2. Please connect "+" to the "VDC" and "-" to the GND.

Description	Min	Rating	Max
Current RMS(A)	2.8	-	7.8
Power Voltage (VDC)	36	68	80
Signal current (mA)	7	10	16
Pulse frequency (KHz)	0	-	300
Pulse width(us)	2	-	-
Direction signal width(us)	100	-	-
Undervoltage protection(VDC)	-	7.5	-
Overvoltage protection (VDC)	-	9.5	-
Cooling mode	Natural cooling		
Ambient temperature(°C)	0~50		
Ambient humidity (%RH)	40~90%		
Vibration	10~55HZ/0.15mm		
Storage temperature (°C)	-20~65		
Weight(g)	570		

### Installation Instructions

1. Reliable operation temperature for Driver should be less than 60°C [135°F] and motor should be less than 85°C [176°F]
2. Recommend to use Automatic Idle-Current mode. It enables to reduce current as 60% when motor stops then help to minimize heating of motor and driver.
3. Recommend to mount driver vertically to maximize heat sink area. If necessary, please apply additional cooling method to cool-down the system.



DS-2MSD8078-2 Driver  
Fit 57 86 Motor

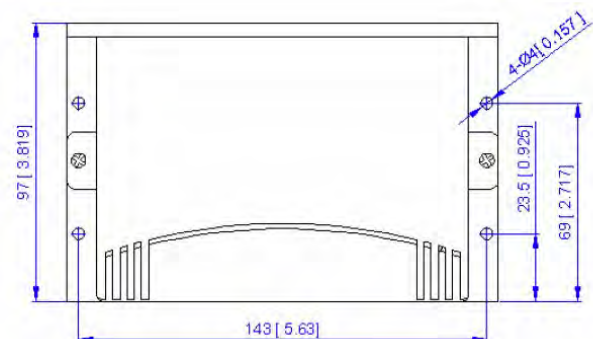
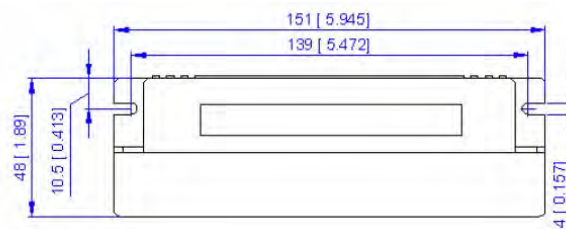

(Side mounting, Good heat dissipation)



■ Positioning Drive Integration DS-OL17/23-I Series

● Summary

Rear motor mounted integrated drive, compact dimension, accurate current and complete protection with RS232, RS485 and CAN2.0 configurations, DS-OL17/23-I Series, allows performances for long distance communication, real-time response and anti-resonance, smoother acceleration and quick deceleration as 0.5sec from 3,000RPM. Fully aluminium housing provides rigid housing protection and fast cooling efficiency.

1. Multiple control mode, Pul, DIR, RS232, RS485 and CAN2.0 communication.

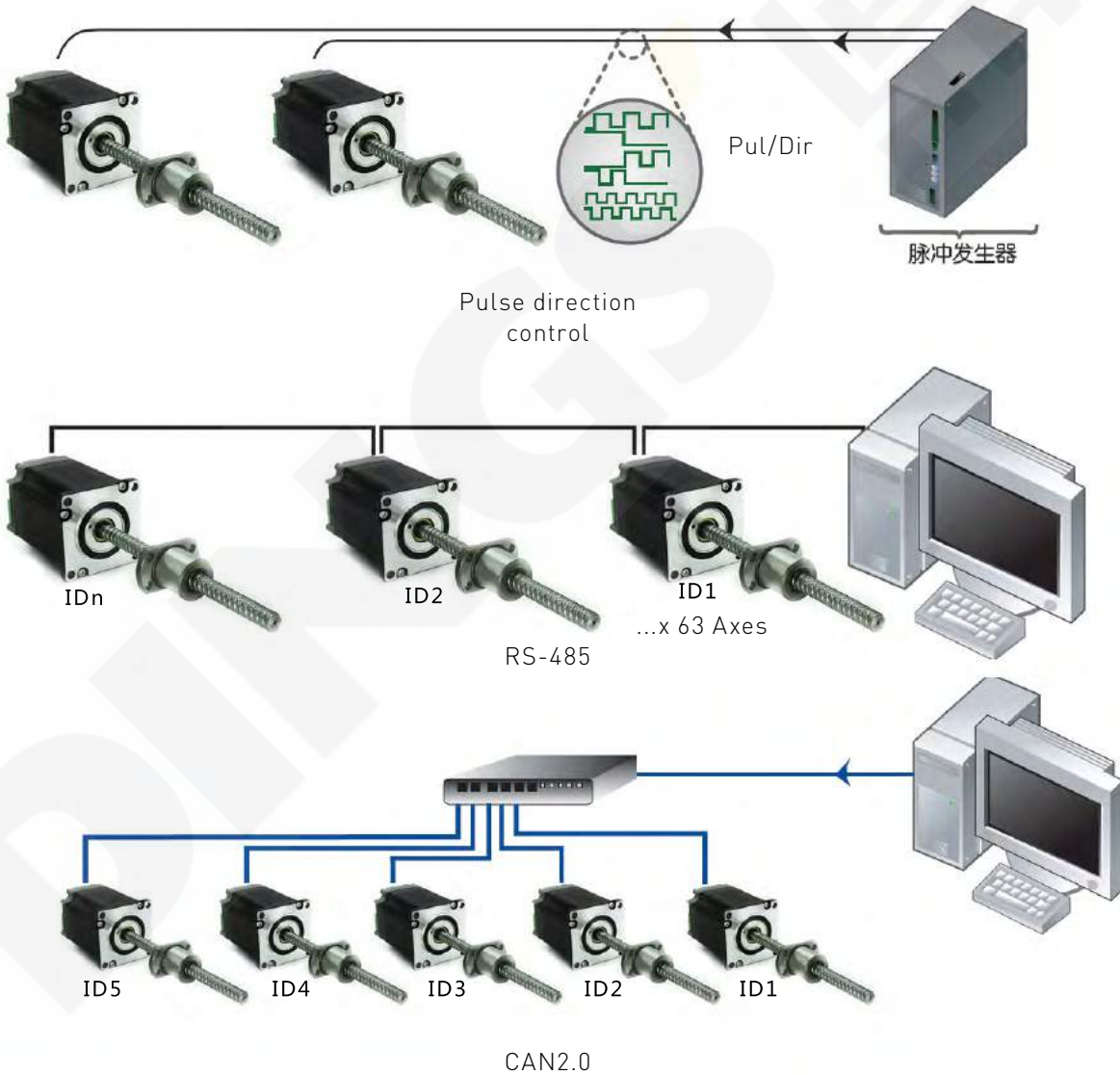

2. Mini design of drive equipped with NEMA17 & 23 size of motors. Fully aluminium alloy housing benefits heat cooling.

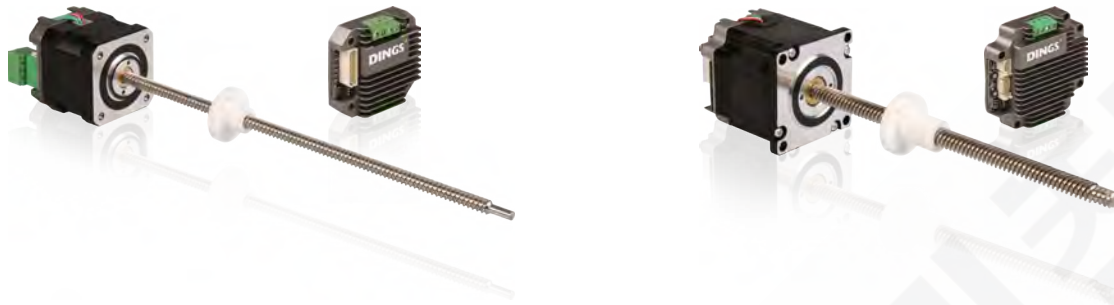

3. S Curve Movement of Acc/Dec enables smoother operation.



4. Microstepping Resolution and smooth running at low speed.

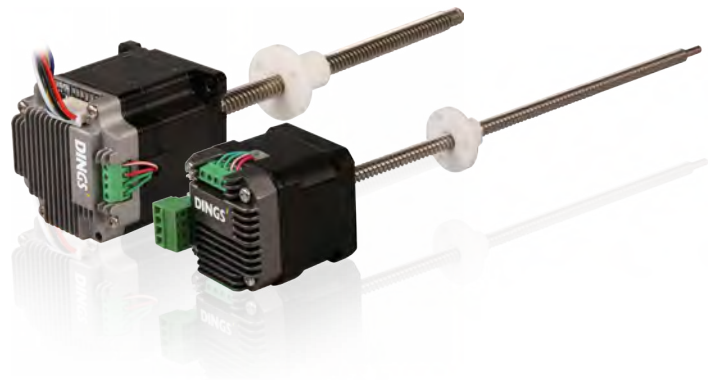
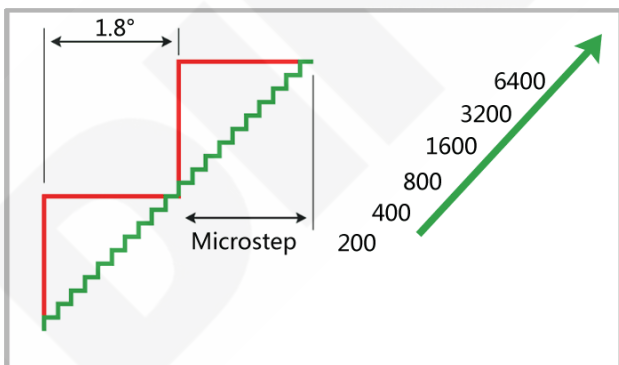

● **System Configuration**

1. PUL/DIR Type

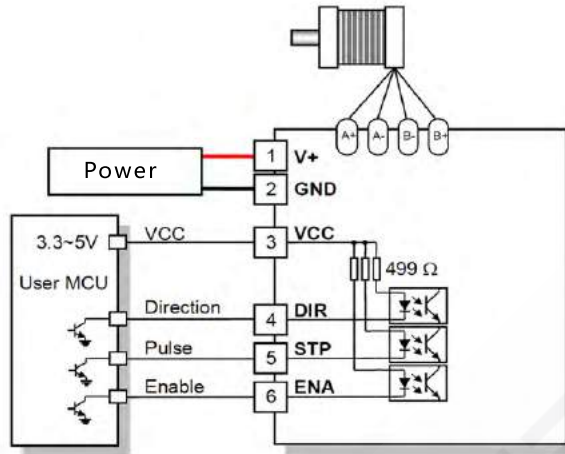

2. RS-485 Type

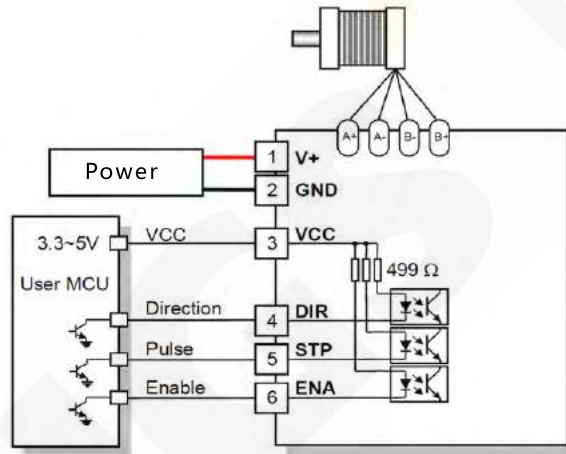

3. CAN 2.0

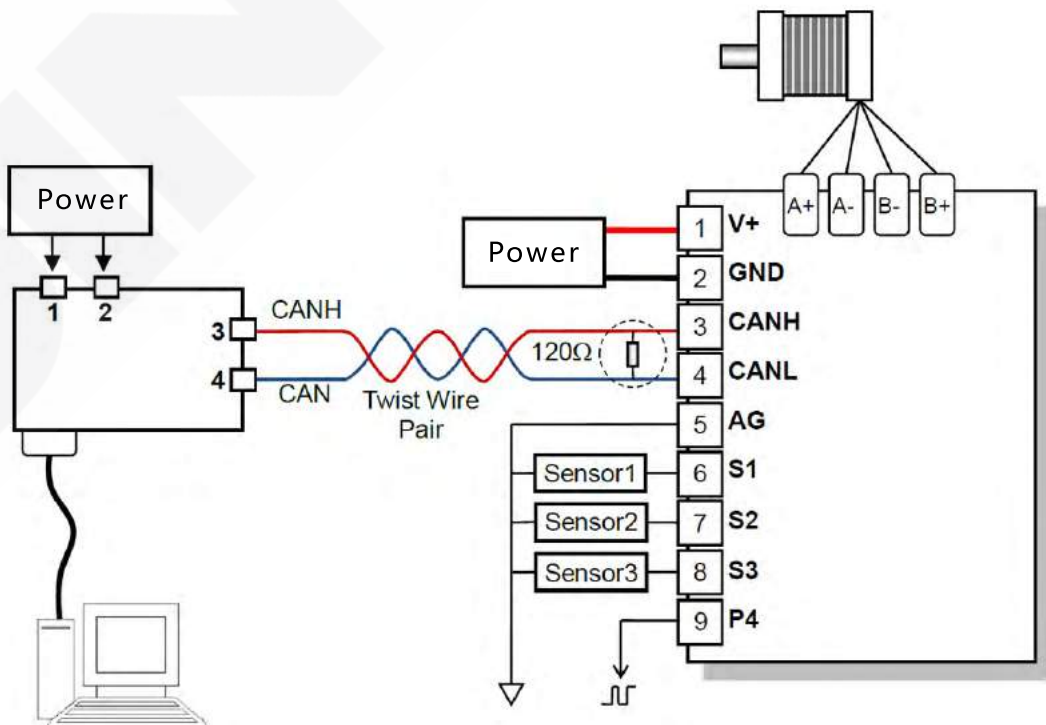

## ● System Specifications

Parameter	Pul、Dir type	RS485 type	CAN type
Power	11~26Vdc and 11~36Vdc	12~32Vdc and 12~36Vdc	12~32Vdc and 12~36Vdc
Output Current	Max 2A and 4.5A		
Driver Way	Chopper constant current PWM control		
Microstep	1~32 and 1~128 Microstep		
Toggle Swith	Controller panel Setting	-	-
Protection Function	Input reverse、 Output short circuit、 Open circuit、 overheating		
Communication	-	RS485-Modbus-RTU	CAN2.0
Communication Ability	-	63 nodes	
Cooling Way	Natural cooling		
Work Environment	Avoid dust oil and corrosive gases		
Work Temperature	-20~90°C		
Work Humidity	<80%RH		
Vibration	3G Max		

## ● Dimension

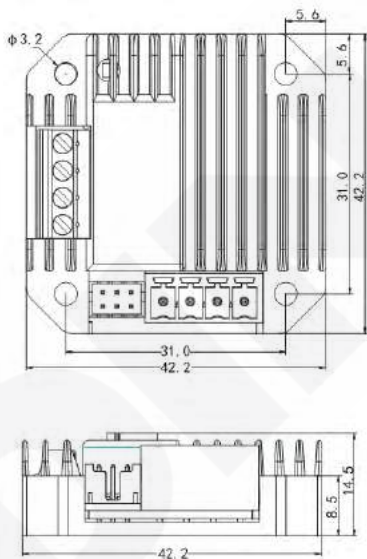

Size 17 series

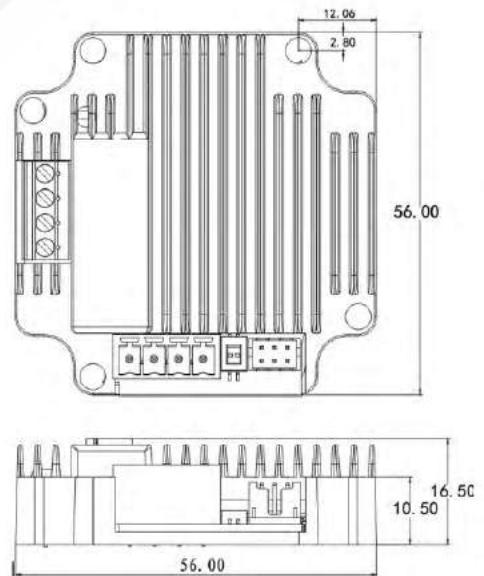

Size 23 series

## ■ Stepping Motor Control System

### ● Summary

Closed loop stepping motor system which perfectly resolves the problems of current open loop control stepping motor system such as step out and positioning completion check.

### ● Advantages

1. Because of mounted encoder constantly monitor the current position, step out cannot be occurred. if step out occurred by external force of overloads, alarm signal will be sent to upper controller. Thus, upper controller can recognize step out of step motor

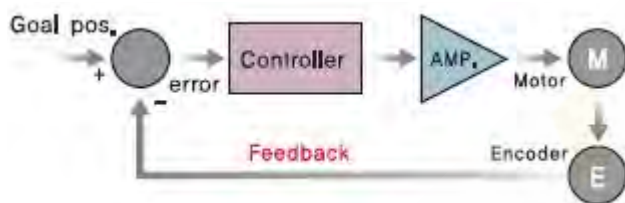

2. Detect current position by encoder feedback so can keep the high torque against the 100% loads and high speed. Current open loop system can not drive 100% loads because of false operation by step out

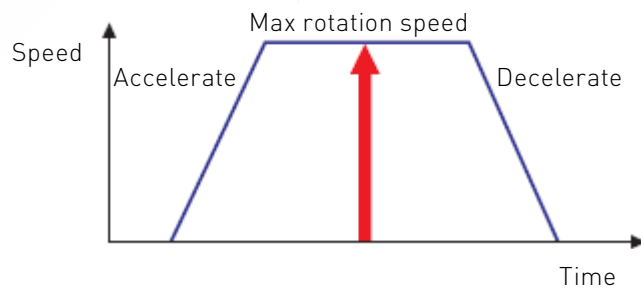
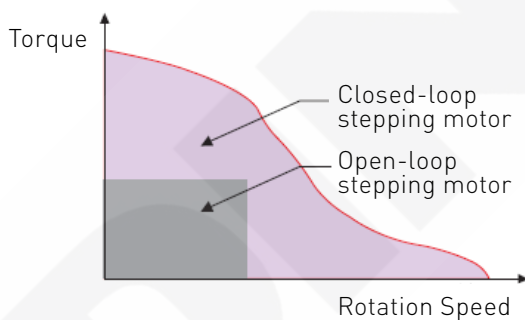



3. It completely stop when motor stops so hunting cannot be occurred.  
It's very suitable for high speed of vision inspection applications.

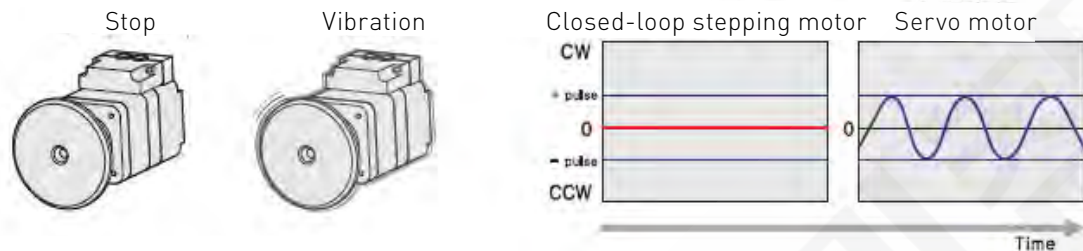

4. By setting of boost current from parameters, it enables to adjust acceleration and deceleration characteristics to be optimized.
5. According to applications and accuracy requirement, customer can select and adjust each different 16 positioning options [500~50000P/R]
6. Based on RS-485 communication connection, multi-axes control supports Max. 16 Axes and baudrate is 9,600~192,000bps.
7. From basic stepping motor control system, position control, speed and torque control modes are also available.
8. Microstep : 1~16 Microstepping selections

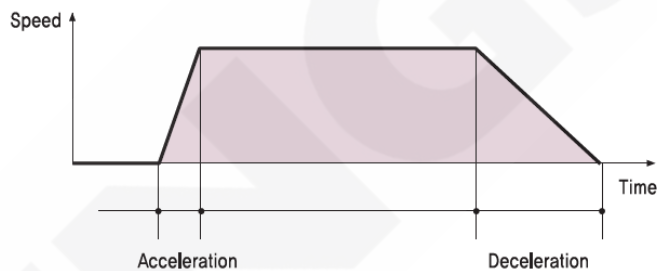

9. Driver and equipment can be protected by 12 kinds of alarms such as motor connection error, encoder connection error and etc.

BACK TO

• **ST484 Close Loop System**

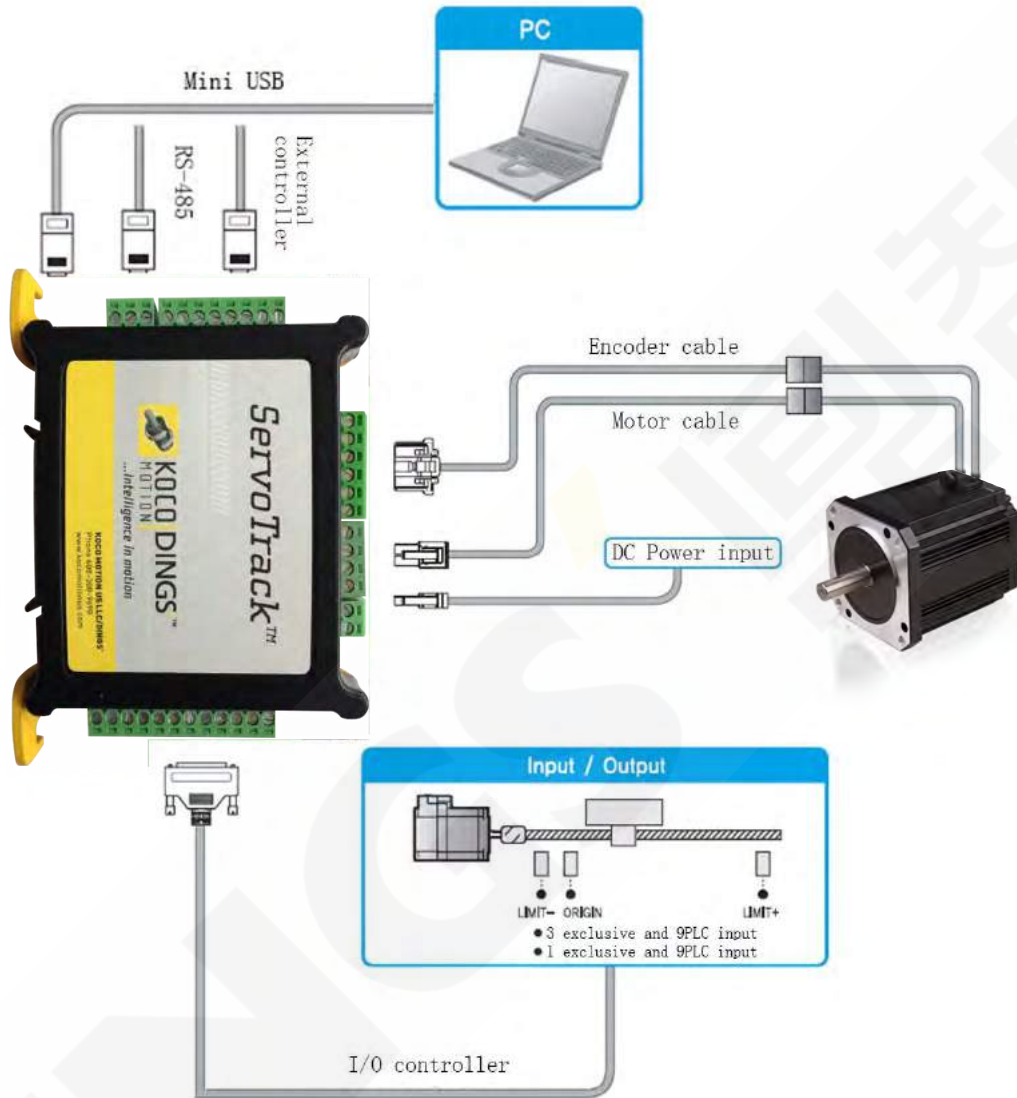

• **Technical Parameter**

Input Voltage:	12-48 VDC±10%
Run Current:	Max 4A
Stop Current:	Adjustable
Max Speed:	1500r/min
Encoder resolution:	100~1024CPR
I/O:	3 Digital Input, 1 Analog Input, 3 Digital Output.
Communication:	USBMini 9600~20000bps
LED:	Monochrome multi state
Microstep:	1~256Microstep
Use interface:	Windows user interface

- Graphical User Interface

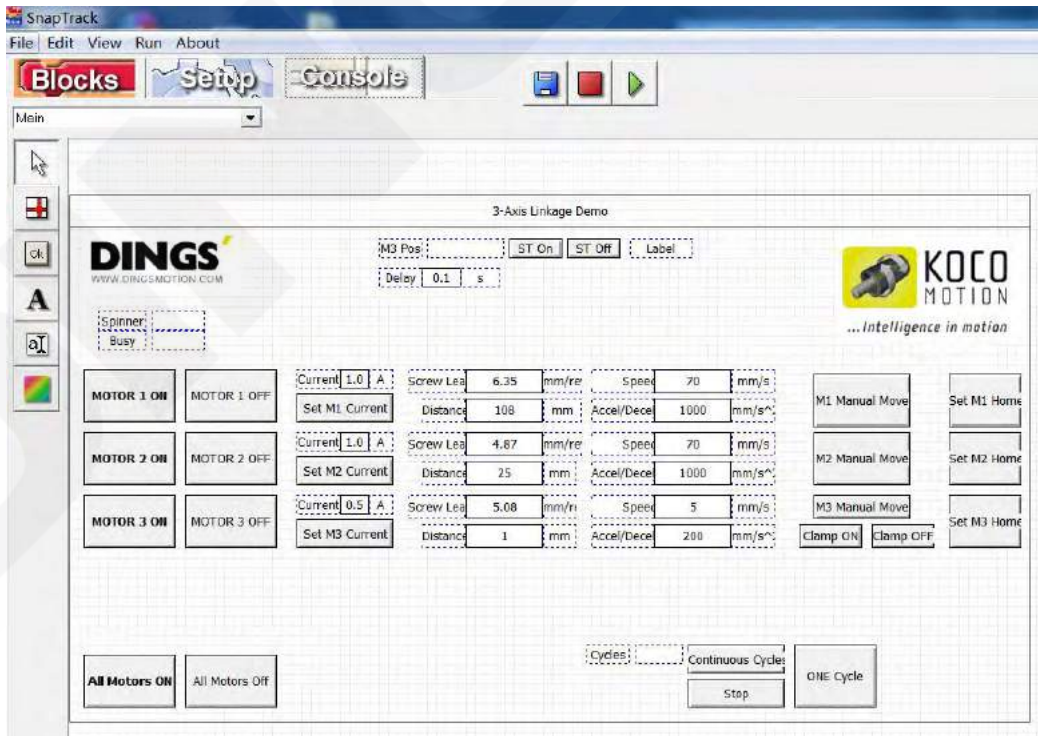
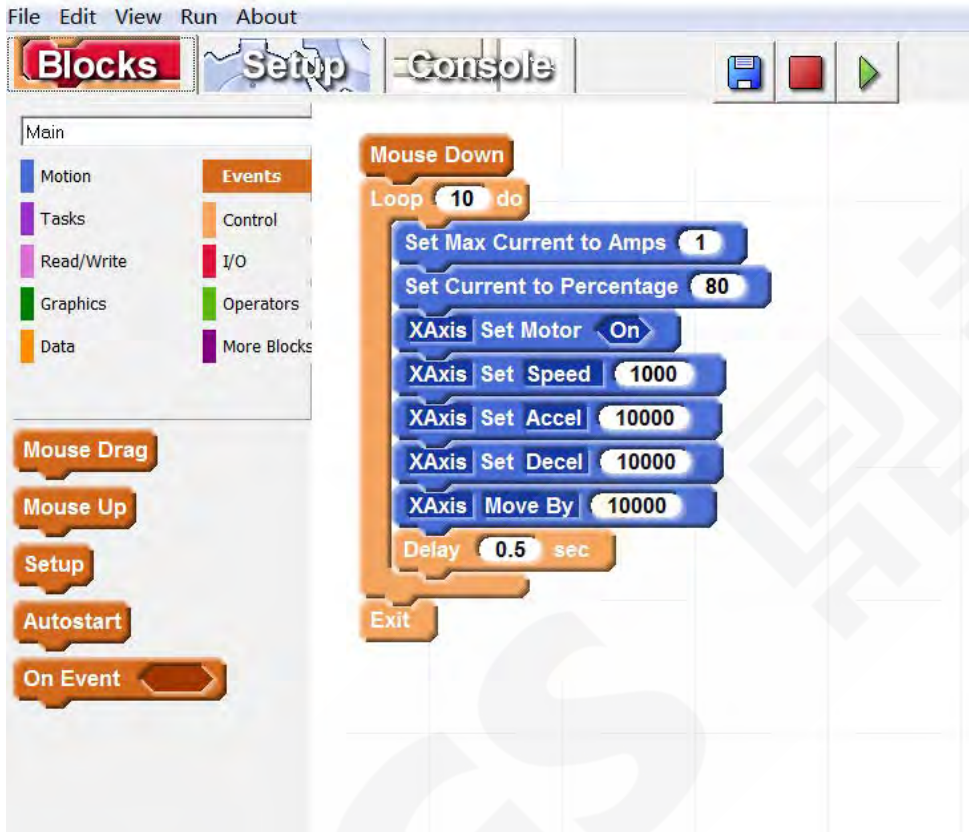

## ■ Vector Series Integrated Systems



Variable Rotary Torque Or Linear Force Control!

### ● Key benefits

- Solve applications previously considered too demanding for stepper Systems.
- HMI Interface
- Reduce system cost with an enhanced stepper based system.
- Do you need torque control in your stepper system?
- Does your system stall due to transient loads or friction?
- Eliminate unintentional stalling or loss of synchronization.
- Increase throughput efficiency
- Reduce motor heating and energy costs with variable current control
- Optimize the torque utilization of your motor
- Greater compliance with inertial mismatch

### ● Features

- ROTARY TORQUE UP TO 300 OZ-IN
- LINEAR THRUST UP TO 200 LBS
- LOW Cost Motion Control Systems
- 12-48 VDC Input
- Dynamic Closed Loop Control
- HMI Interface Capable
- Up to 256 uSteps / Full Step
- USB Programming Interface
- Multifunction Diagnostic LED
- SnapTrack™ Programming Software
- Secondary Encoder input for Electronic Gearing OR Camming
- Distributed Motion for Multi-Axis Control (Master and Slave)
- RS485 Communication and Command Structure (Dynamic Link Library)
- Qty 3 Programmable Inputs (5-24VDC)
- Qty 3 Programmable Outputs (5-24VDC)
- Qty 1 16 Bit Analog Input
- 5 VDC output on board



Product Selection Systems					
1	V = Vector Series				
2	Drive Option	<input type="checkbox"/> D = Drive ONLY	<input type="checkbox"/> P = Programmable Controller and Driver		
3	Linear Version	<input type="checkbox"/> E = External	<input type="checkbox"/> N = Non-Captive	K = Captive	C = Electric Cylinder
4	Motor Length (See Speed /Force Curves)	<input type="checkbox"/> 1 = Single Stack	<input type="checkbox"/> 2 = Double Stack	<input type="checkbox"/>	<input type="checkbox"/>
5	Lead Screw Code	See Table on page 5 (See Screw Lead Selection Table AND Speed / Force Curves)			
6	Lead Screw Length/Stroke	<input type="checkbox"/> XXX = length in mm (For External and Non-Captive)	<input type="checkbox"/> XXX = mm Stroke stroke (For Captive and Electric Cylinder)		
7	Lead Screw Surface	<input type="checkbox"/> S = Standard / No Teflon Coating	<input type="checkbox"/> T = Teflon Coating		
8	End Machining (see Table XX)	<input type="checkbox"/> M = Metric	<input type="checkbox"/> U = UNC	S = Smooth	N = None
9	Nut Version	<input type="checkbox"/> S = Standard Free Wheeling Nut	<input type="checkbox"/> A = Anti-Backlash Nut	<input type="checkbox"/>	<input type="checkbox"/>

NOTE: Radial (Side) Loading Of The Lead Screw Or Shaft Is Not Recommended!

## Electric Cylinder

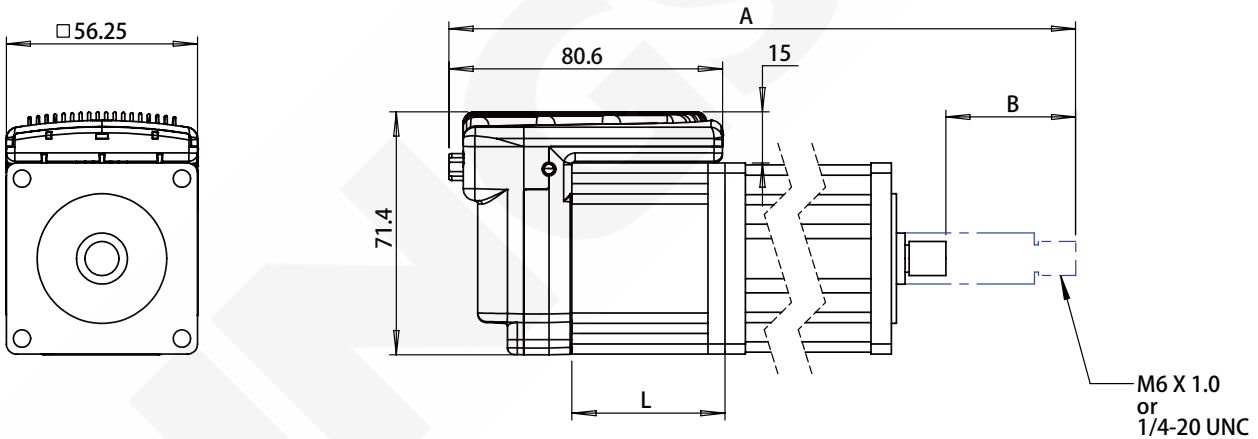

## Stroke Specification

Stroke B inch (mm)	A (mm)	Dimension L (mm)	
0.50 (12.70)	45.70	Single Stack Motor 47 Mm	Double Stack Motor 66 Mm
0.75 (19.05)	52.05		
1.00 (25.40)	58.40		
1.25 (31.80)	64.80		
1.50 (38.10)	71.10		
2.00 (50.80)	83.80		
2.50 (63.50)	96.50		



### Non-captive Linear Vesion

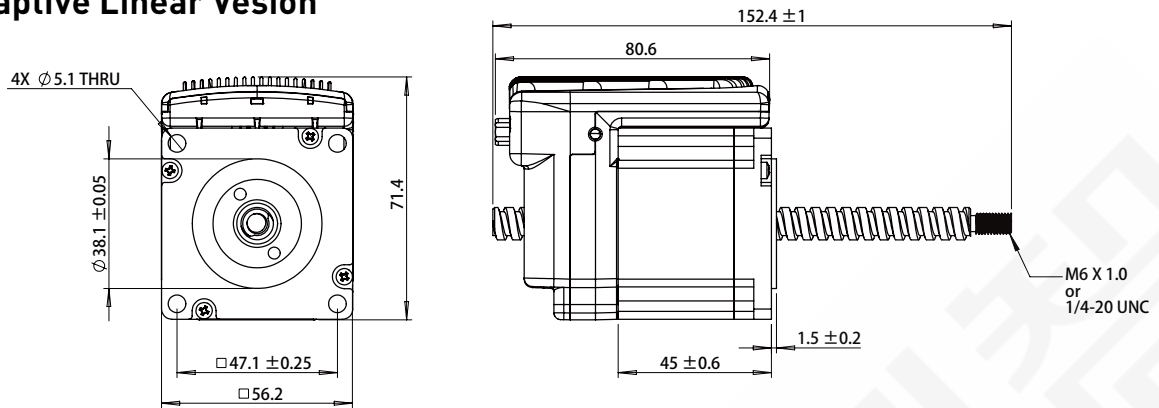

### External Linear Vesion

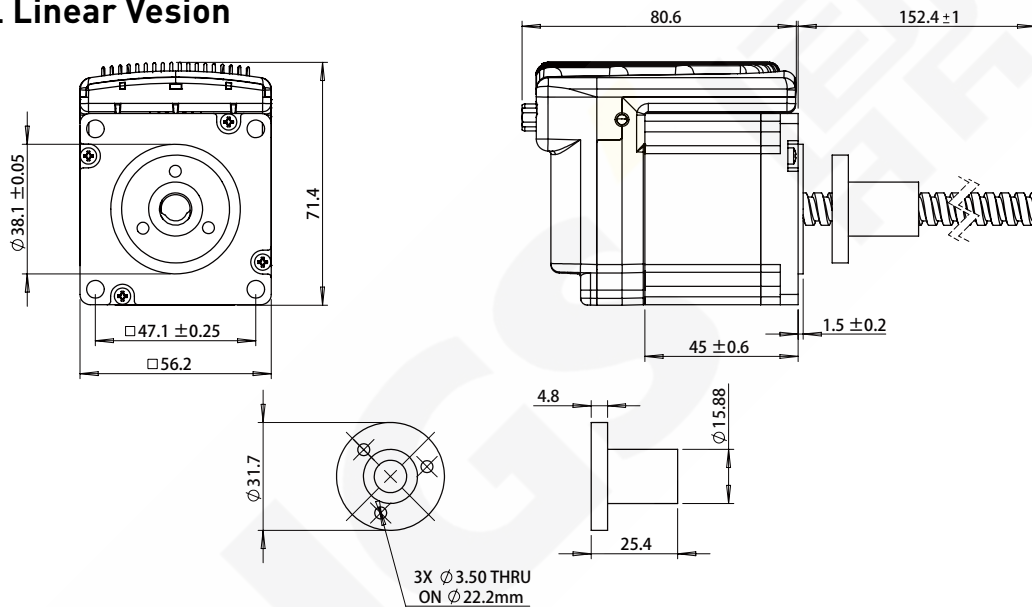

### Captive Linear Version

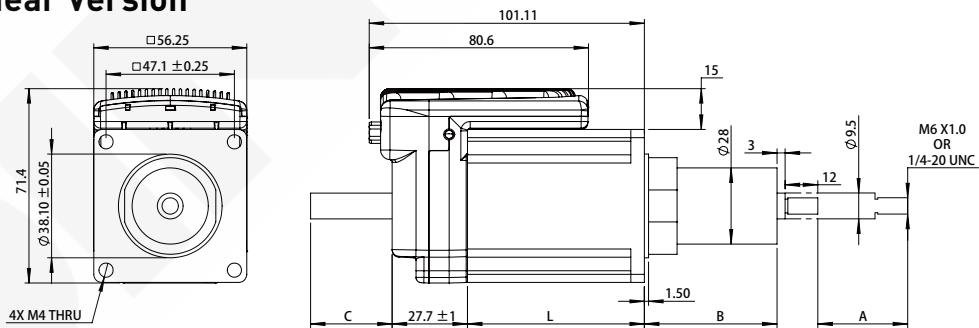

### Stroke Specification

Stroke A (mm)	B (mm)	Single Stack Motor Length L= 45mm	Double Stack Motor Length L= 65mm
		Max Lead Screw Rear Extension (Fully Retracted) C(mm)	
12.70	23.30	0	0
19.05	29.65	0	0
25.40	36.00	0	0
31.75	42.35	0	0
38.10	48.70	6	0
50.80	61.40	18.7	8.7
63.50	74.10	31.4	21.4

Product Selection Systems		
1	V	Vector Series
2	P	Programmable Controller with Driver
3	23	Nema Size
4	H	Rotary Version
5	Motor Selection: [See Speed /Torque Curves]	-45 = 0.8 Nm Torque Motor -55 = 1.2 Nm Torque Motor -75 = 2.0 Nm Torque Motor
6	-GR	Gearbox Ready
7	-PG10	Planetary Gearbox (10:1 Ratio)
8	-XYZ	Custom Suffix

## EXAMPLES

VP23H-45

VP23H-55-GR

VP23H-75-PG10

VP23H-45-XXX-001 = Custom Suffix

## Rotary Versions

### 45 Option

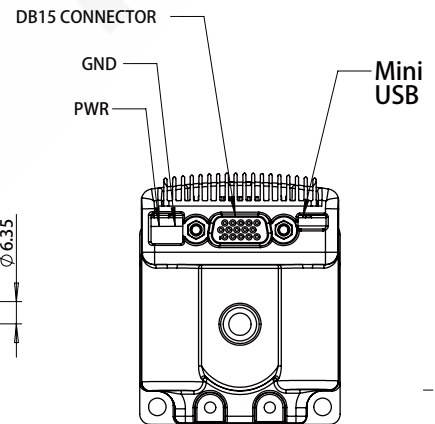
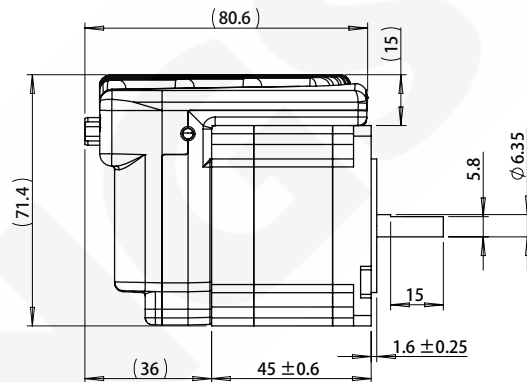
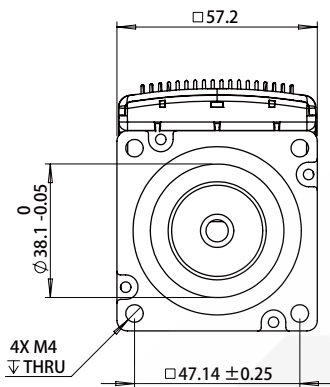

### 55 Option

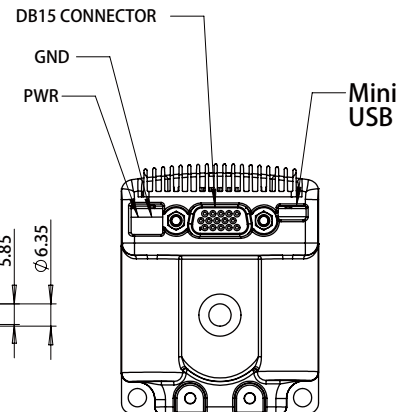
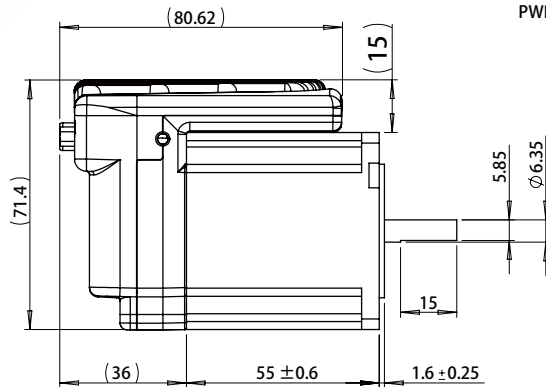
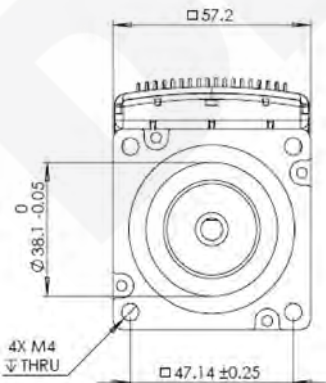

● **75 Option**

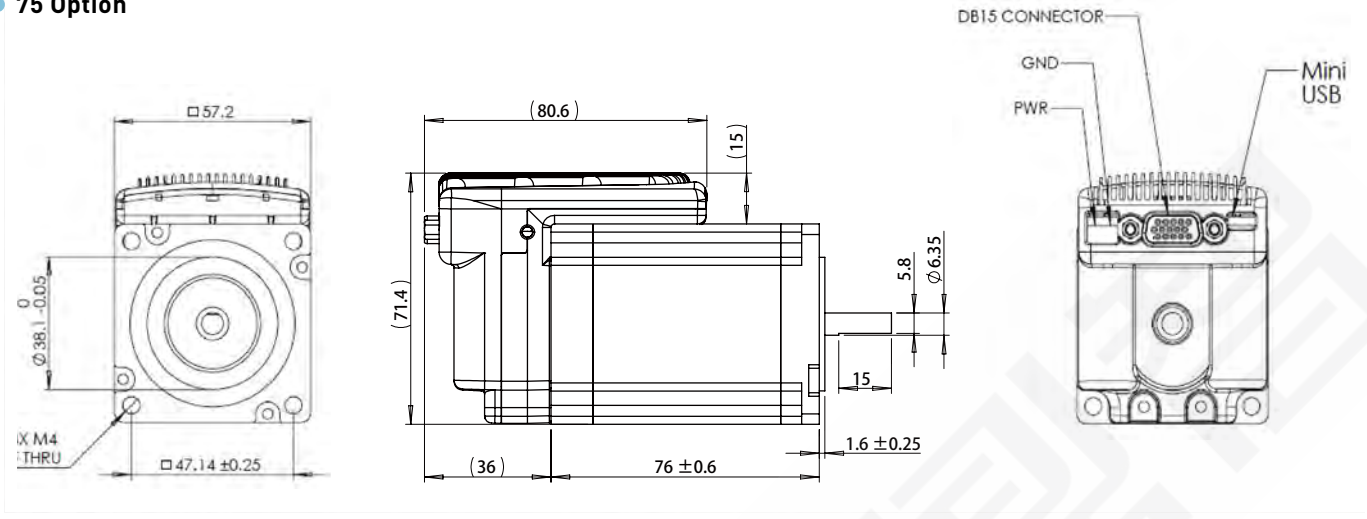

■ **VBB-1 BREAKOUT BOARD**

**DB15 Pin Breakout Board  
For Rapid Prototyping**

The optional breakout board is ideal for rapid prototyping and proof of concept designs. The breakout board may be plugged directly into the Vector unit.

Signals are accessed via a pluggable 15-pin Phoenix clamp-type terminal connector.

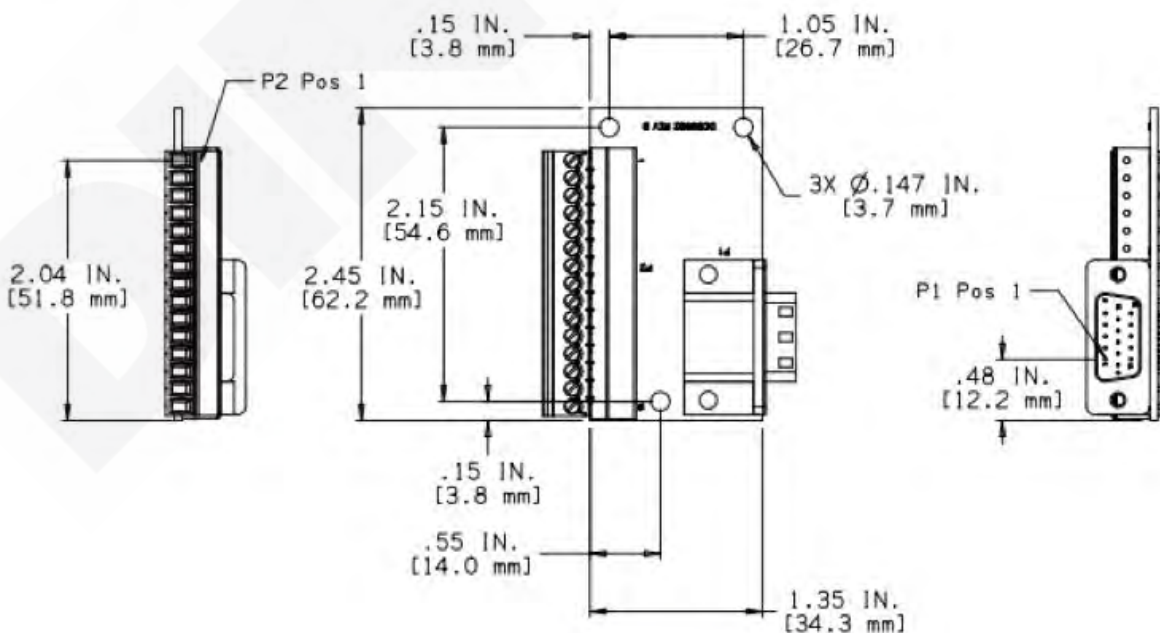
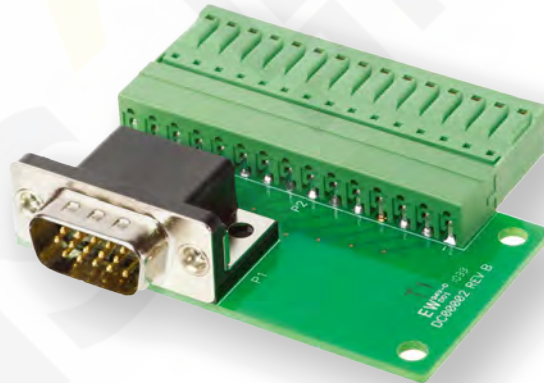

NOTE: Please reference the complete hardware and Snaptrack™ software manuals at our website:  
<http://www.kocomotionus.com/>

■ **DS-CL28-SA Integrated Closed-loop Drive**

● **Summarize**

Closed-loop stepper motor integrate. At the end of motor drive integrated control system. Including high resolution encoder, every 25ms update the motor position in real time. Integrated motion control through the RS485 communication to the computer, also can connected 16 shaft at the same time. All of the moving conditions are performed by a parameter saved in the FLASHROM. The movement library (DLL) provides the maximum 64-bit program of Windows2000 / XP, can be save in FLASHROM memory.



● **Feature**

1. Base on the network movement control, can be through RS-485 & PC connect .All the motion parameters are stored in the FLASH ROM.  
The maximum can be connected to be 16-axis.



2. Closed loop controller system-integration High resolution encoding, each 25MS updates the motor location in real time.

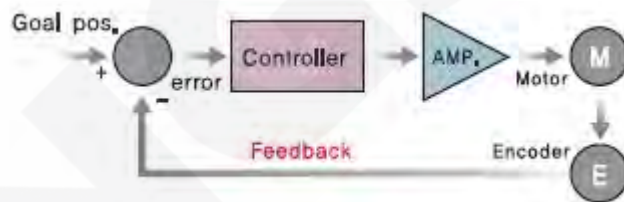

3. High torque, High rotate speed compare with ordinary motor, can make the motor at running 100% working condition without losing step.

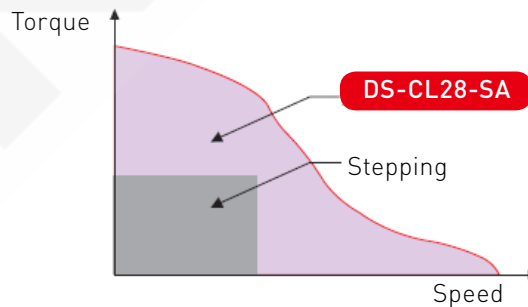

4. Self- closed loop torque control, which replace the external pressure sensors. By regulating current, implementation return to origin, under-draught torque control.

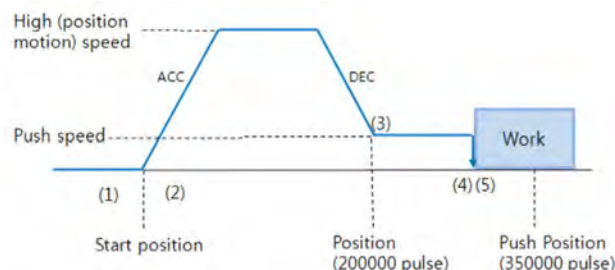

● **System layout**

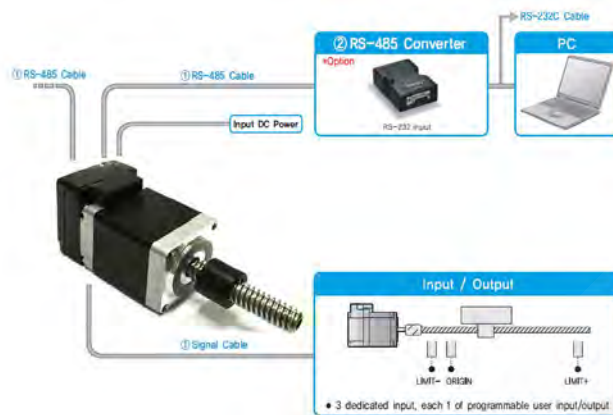

**Input /Output Port definitions**

Port	Function	Description
1	GND	Power GND
2	+24V	+24V Power Input
3	I/O Common	Input/Output Signal common terminal
4	ORGIN	Sensor input Origin
5	LIMIT+	Sensor Input LIMINT+
6	LIMIT-	Sensor Input LIMIT-
7	IN1	User Input(User Input0 )
8	OUT1	User Output(User Output1)
9	Termination	Sensor input for LIMIT
10	Data+ (B)	Communication signal(RS-485)
11	Data+ (A)	Communication signal(RS-485)
12	GND	Power GND(Communication signal GND)



Parameters	
Description	description
Input Voltage	24VDC±10%
Control Method	Closed loop control with 32bit DSP
Multi Axes Driver	Max 16 axes through daisy-chain
Location table	64 movement command steps (continuous cycle Jump etc)
Current Consumption	Max 500mA(Except motor current)
Ambient Temperature	Use:0~55°C Storage:-20~70°C
Ambient Humidity	Use:35~85%RH Storage:10~90%RH
Anti-knock	0.5G
Rotation Speed	0~3000rpm
Resolution (P/R)	Max 16000PPR
Protection Functions	Multiple alarm function, Reference practical manual
Rotational Direction	CW/CCW(Selectable by parameter)
Input Signal	LIMIT+, LIMIT-, ORIGIN,1 programmable input(optocoupler)
Output Signal	1 programmable Output
Communication interface	RS-485 Serial communication with PC Transmission speed: 9600~921600(bps)
Position Control	Incremental mode Data range: -134217727 to +134217727[pulse] Pules speed: Max 500(kpps)
Return to Origin	Origin sensor, ±Limit sensor
GUI	User interface program within windows
Software	Motion library(DLL) for windows 2000/xp/7/8/10

● Size

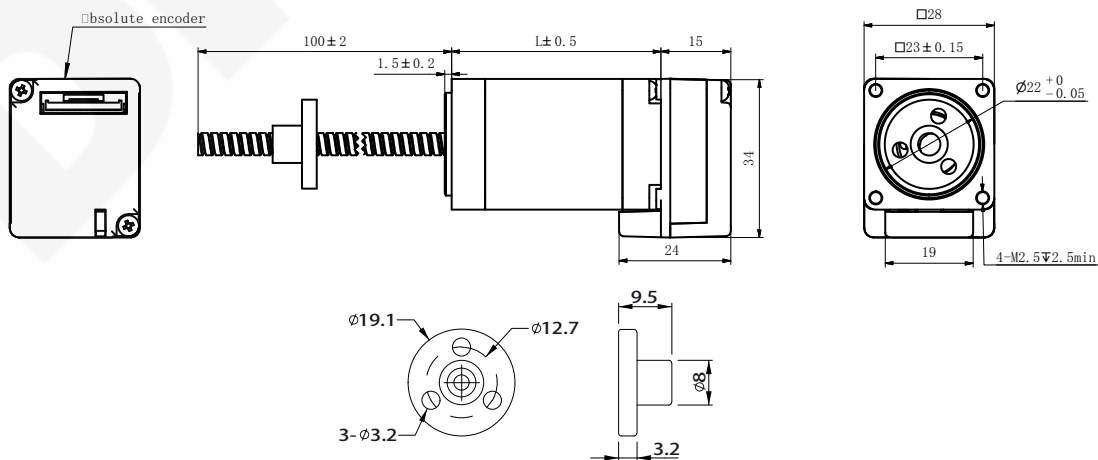

● Typical connection

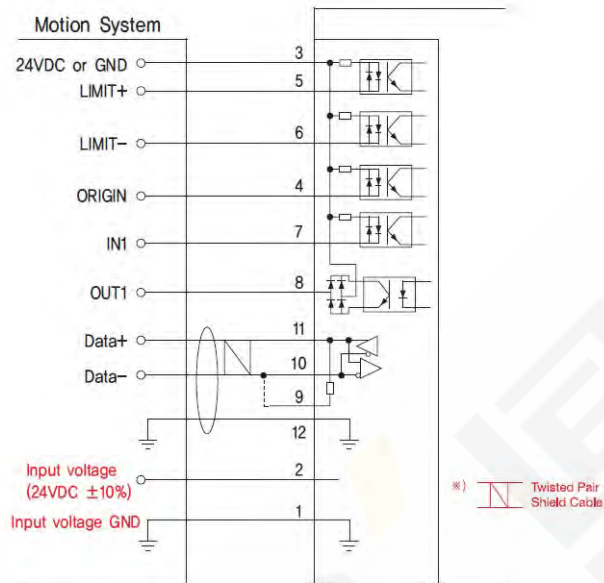

● Port signal



**Optional accessories**

FAS -RCR (RS-232C RS -485 converter)

Item	Specifications
Comm. speed	Max 1152Kbps
Comm. Distance	RS-232C: Max 15m RS-485: Max 1.2km
Connector	RS-232C: DB9 RS-485: RJ-45
Size	50x75x23mm
Weight	38g
Power	Self-Powered RS-232C (DC5~24V external power available)



## ■ DS-CL28-SA Setting and Operating

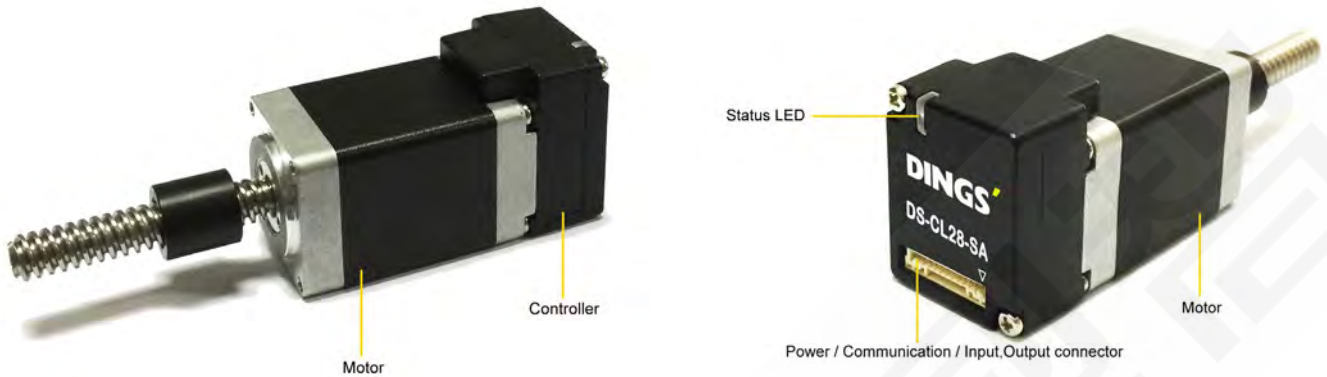

### ● Status LED

In the case of DS-CL28-SA series products, status of LED can be checked by LED color lighting on / off and blinking.

Status	Function	On/Off status
Disable	Green: Red:	Green light flashing, Red light off
Enable	Green: Red:	Green light flashing, Red light off
Enable & Communication	Green: Red:	Green light on. Red light flashing
In Motion	Green: Red:	Green & Red light on
Inposition deviation	Green: Red:	Green and red light alternately flashing
Alarm	Green: Red:	Red light flashing repeat as many as alarm number

### ● Protection function and status LED flash times

Times	Protection	Conditions
1	Over Current Error	The current through power devices in inverter exceeds the limit value
2	Over Speed Error	Motor speed exceed 3000rpm
3	Step Out Error	Position values is higher than specified value in motor stop status
4	Over Load Error	The motor is continously operated more than 5 second under a load exceeding the max. torque
5	Over Temperature Error	Inside temperature of drive exceeds 85°C
6	Over Regeneratived Voltage Error	Back-EMF more than high limit value
7	Motor Connect Error	The power is ON without connection of the motor cable to drive
8	Encoder Connect Error	Cable connection error with Encoder connector in drive
9	Low Input Voltage Error	The power supplied to the motor is less than low limit value
10	Inposition Error	After operation is finished, a position error occurs
12	ROM Error	Error occurs duhng tuning execution
15	Position Overflow Error	Position error value is higher thab 90 ° in motor stop state

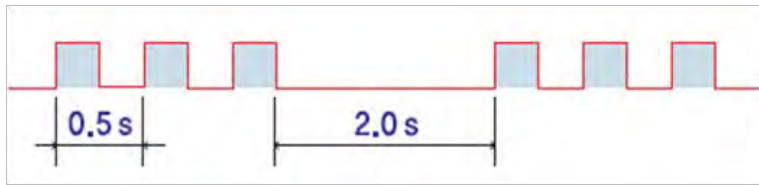

Alarm LED flash (ex: Position tracking error)  
 Default value can be changed by parameter (Refer to Manual)

● **Network ID setting**

The network ID of DS-CL28-SA series can be set using Ezi-Moiton Plus-R GUI (Version 6.40.7.12 or later). After connecting the communication, the setting window appears by selecting the product and press the right button of the mouse.

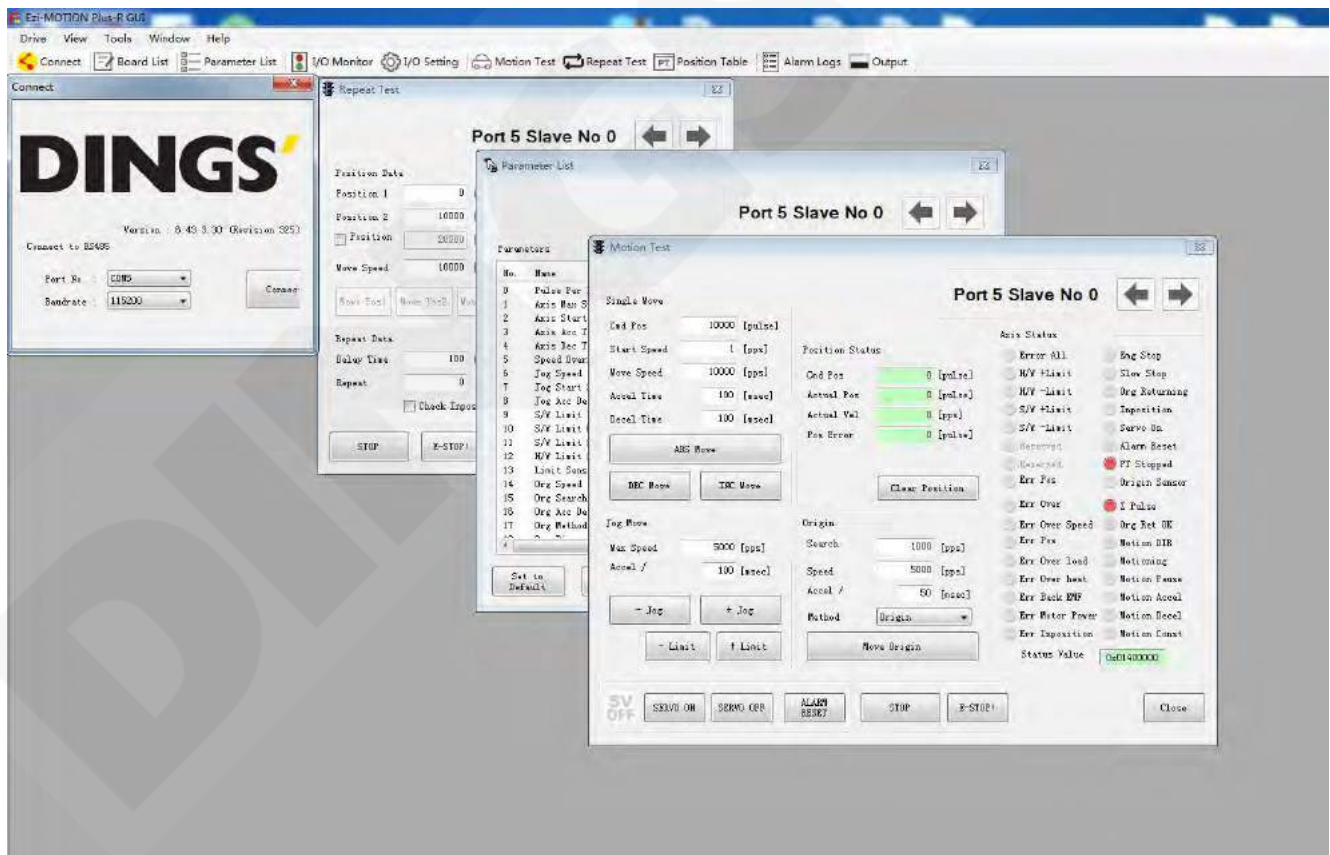

**Compact Linear Actuators with Stepping Motor & Ball Screw  
DS-DLG42(Effective stroke:40mm)**



- 1.This product features a stepper motor integrated with a ball screw. It is a suitable actuator for pushing and pulling loads and fine-tuning applications.
- 2.Compact and Lightweight.
- 3.High efficiency & high accuracy.
- 4.Significantly Fewer Parts and Required Assembly Time.

● **Dimension**

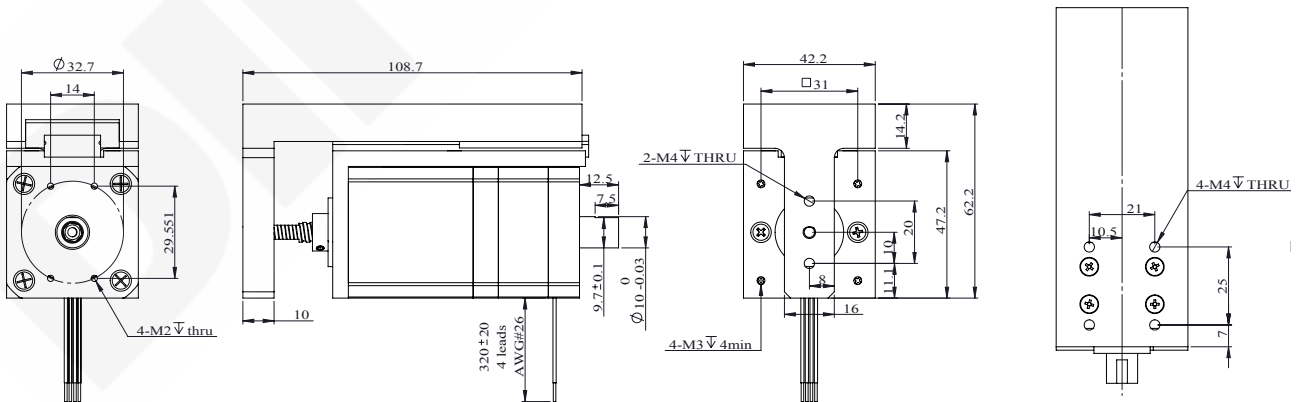



## ■ IP54 Coating



- 1.Coating is of epoxy resin primer and blue polyurethane finish with thickness of 0.1 - 0.15 mm.
- 2.Coated surface can withstand salt spray test up to 48 hours.
- 3.Wiring connections use industrial threaded connector, capable of anti-vibration and anti-squeezing, obtaining protection class of IP 54.

**FOR MORE INFORMATION, CONTACT YOUR LOCAL  
DINGS' REPRESENTATIVE (REFERENCE CATALOGUE BACK COVER)**



# DINGS

## Headquarters-Asia

### **DINGS' Electrical & Mechanical Co., Ltd.**

3rd Floor, Block C, Tian'an Industrial Park  
New District, Changzhou Jiangsu, China

Phone +86 519 85177826, 85177827

Fax +86 519 85177807

**[www.dingsmotion.com](http://www.dingsmotion.com)**

## Shenzhen Office

Room 633, Wanjunhui Building,  
Xixiang Flyover, Bao'an District,  
Shenzhen City, Guangdong Province, China  
Phone +0755-23141175

## Korea Branch

No.822 8F Medwiz Building Daehwa-dong,  
Juangang-Ro 1565, Ilsan Seo-Gu, Goyang-Si  
Gyeonggi-Do, Korea  
Phone +82-10-27339770  
Fax +82-319191602

## Headquarters-North America

### **DINGS' MOTION USA**

335 COCHRANE CIRCLE  
MORGAN HILL, CA 95037

Phone +1 408-612-4970

[sales@kocomotionus.com](mailto:sales@kocomotionus.com)

**[www.kocomotionus.com](http://www.kocomotionus.com)**

## Sales Representation-Germany

### **KOCO MOTION GmbH**

Niedereschacher Straße 54  
78083 Dauchingen  
Germany

Phone +49 7720 995858-0

Fax +49 7720 995858-9

[info@kocomotion.de](mailto:info@kocomotion.de)

**[www.kocomotion.de](http://www.kocomotion.de)**



This catalog is the sole property of Dings' and without the written authorization of Dings', any copy or forwarding is prohibited.

Dings' reserves the right to make changes without further notification to any products herein to improve the reliability, function or design.

Dings' reserves the final interpretation.

REV0414